



Clemas & Co Ltd

Industrial Cleaning Equipment
Sales - Hire - Service

512 & 712 PEDESTRIAN SWEEPER OPERATOR MANUAL



Clemas & Co. Unit 5 Ashchurch Business Centre, Alexandra Way, Tewkesbury,
Gloucestershire, GL20 8NB.

Tel: 01684 850777

Fax: 01684 850707

Email: info@clemas.co.uk

Web: www.clemas.co.uk

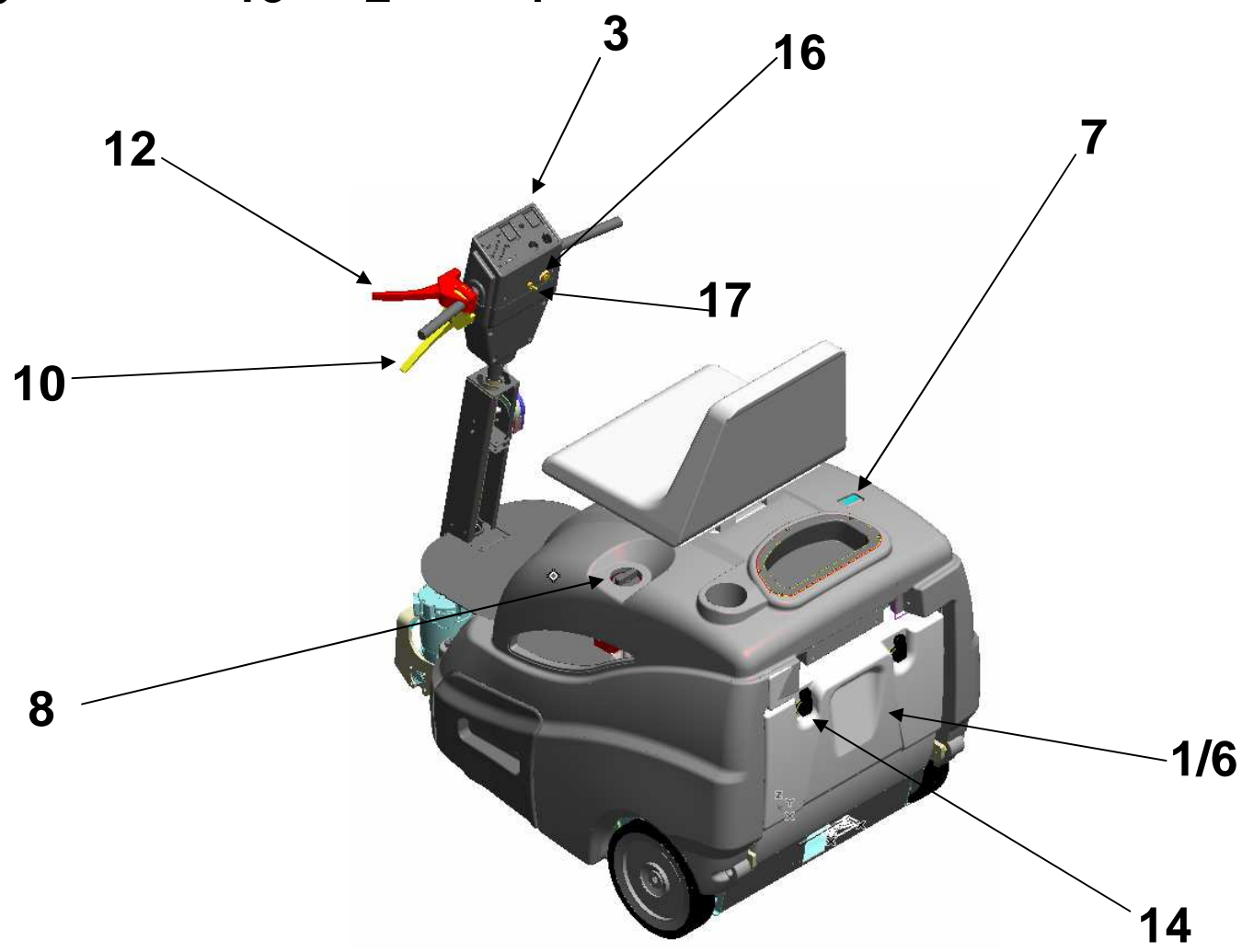
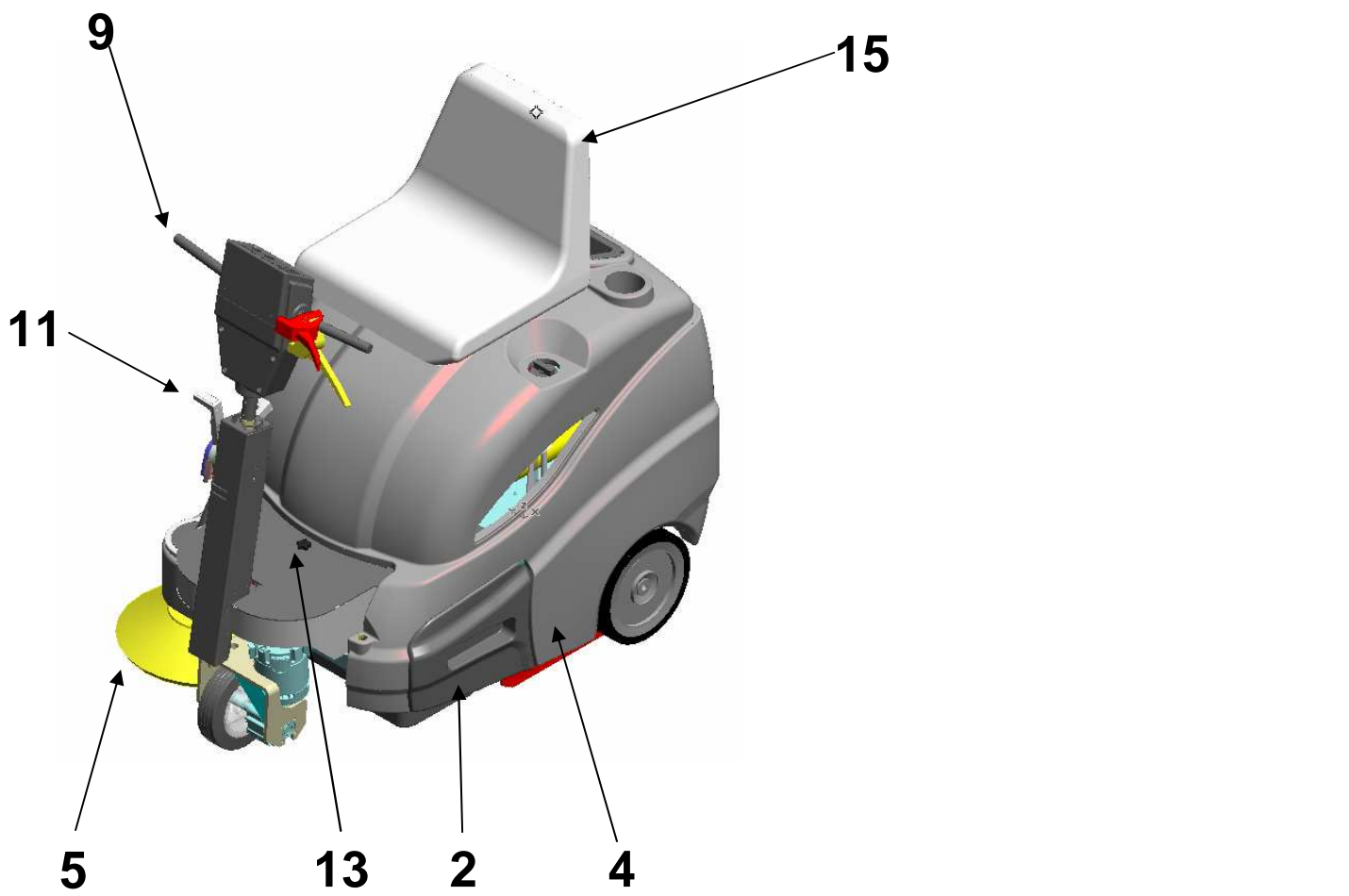

A

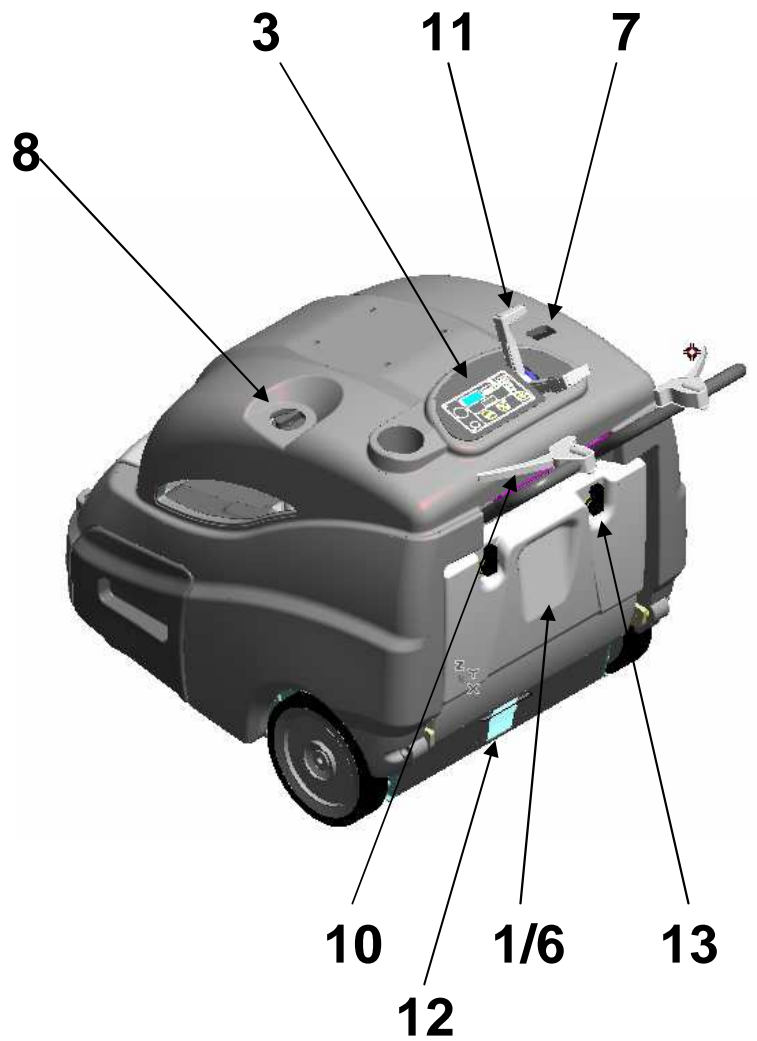
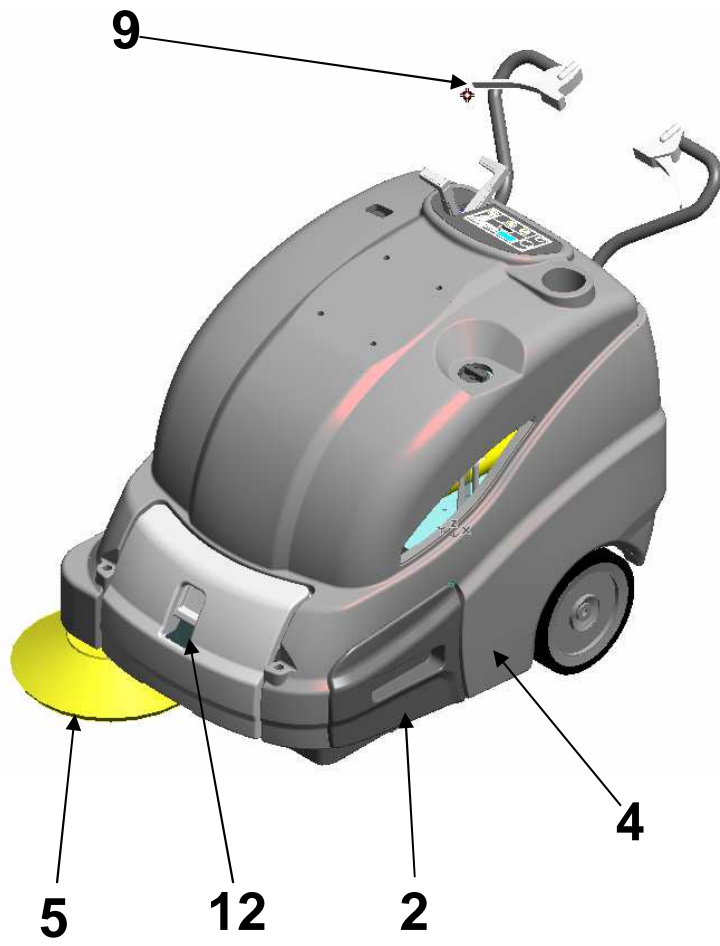

B

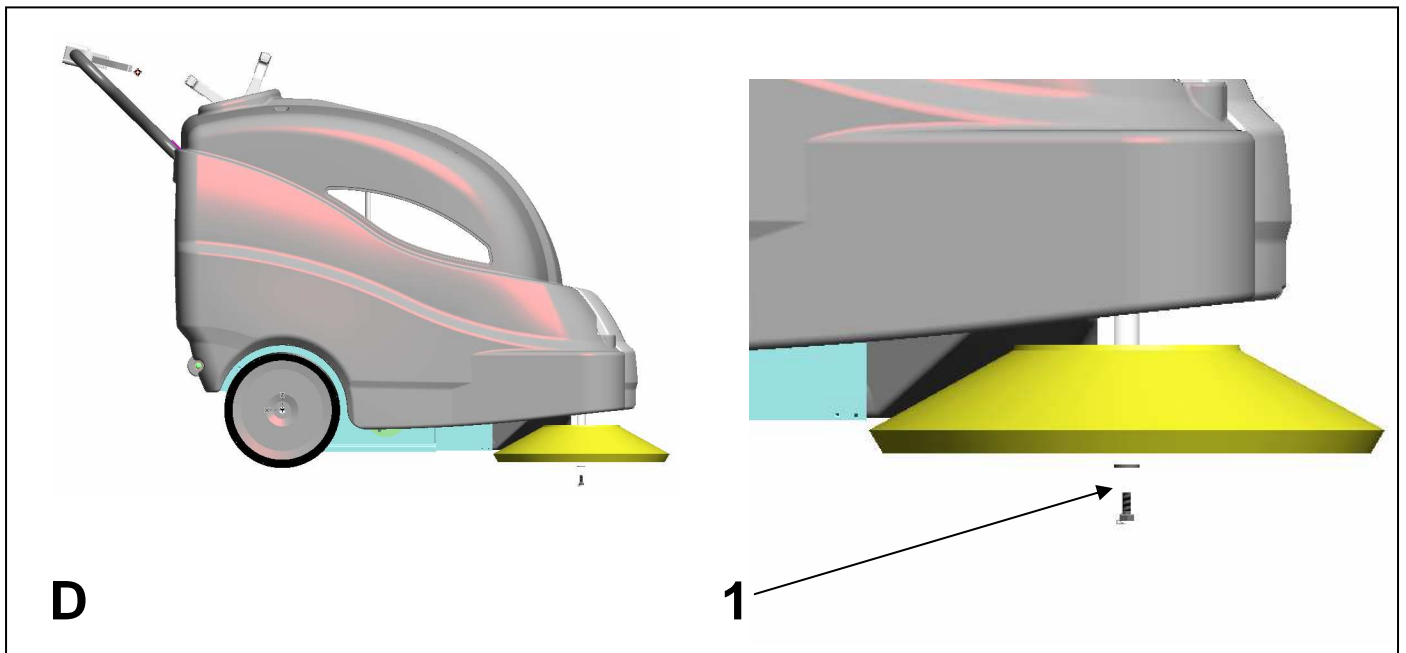
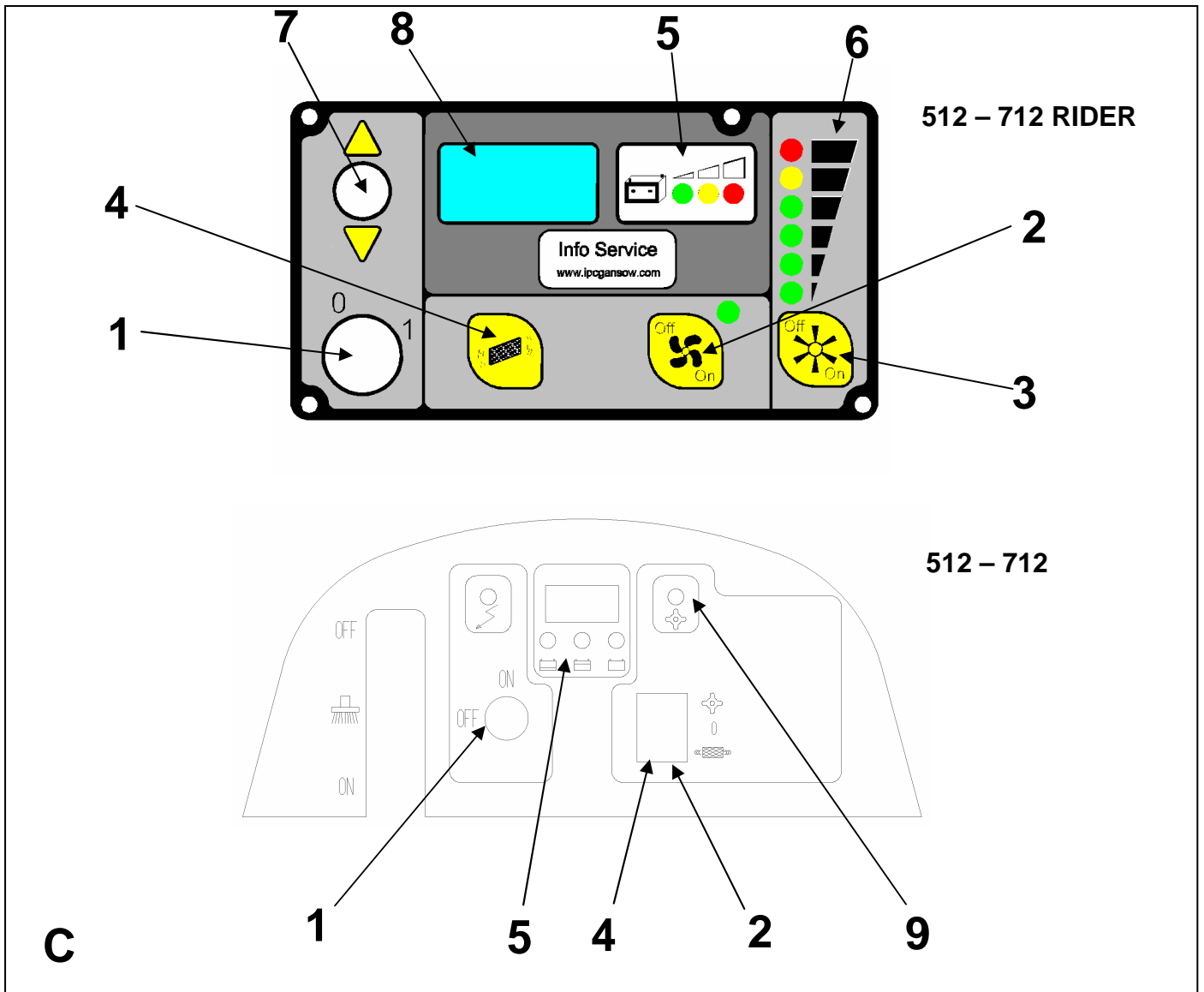

E

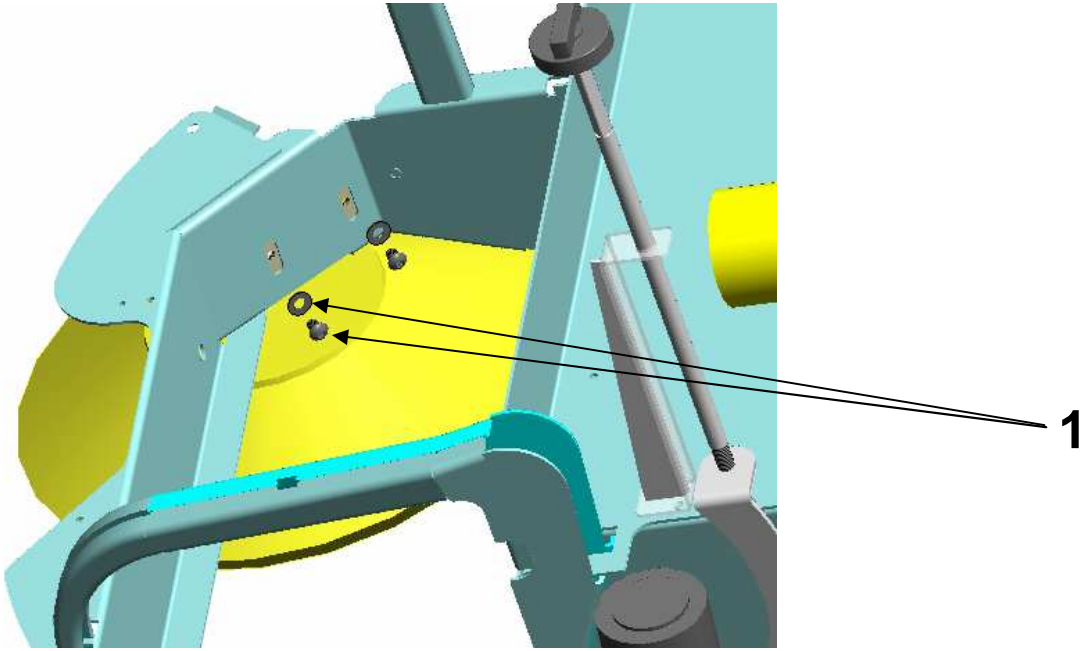

F

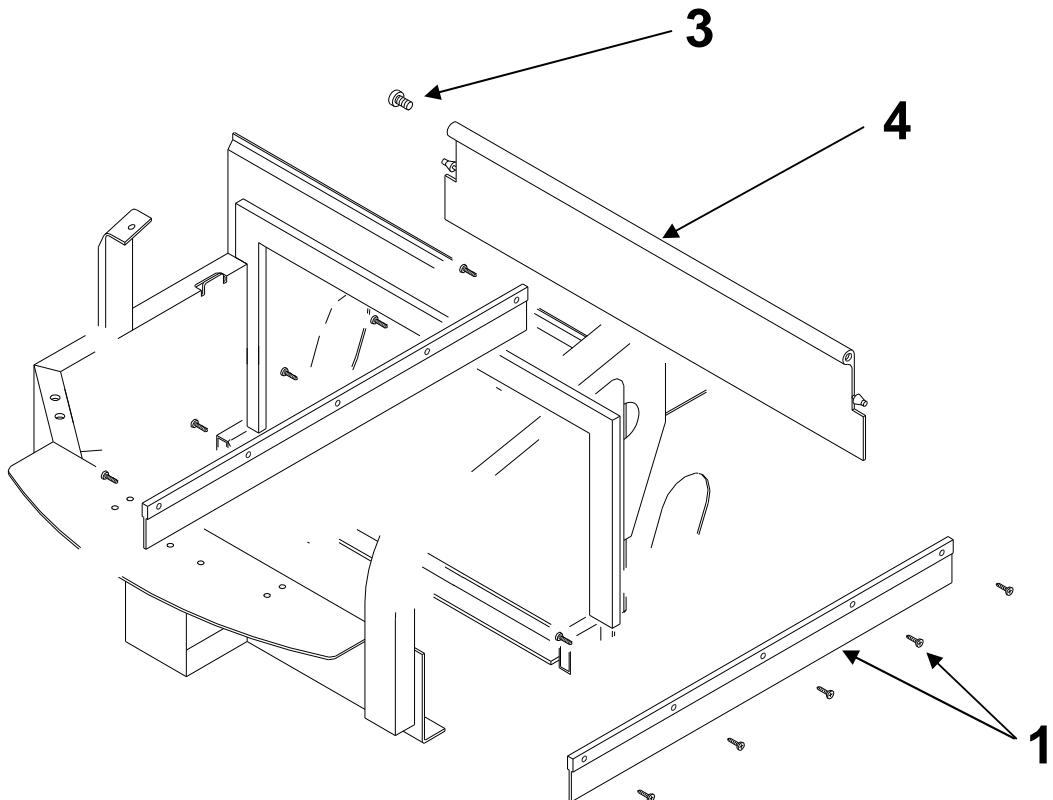

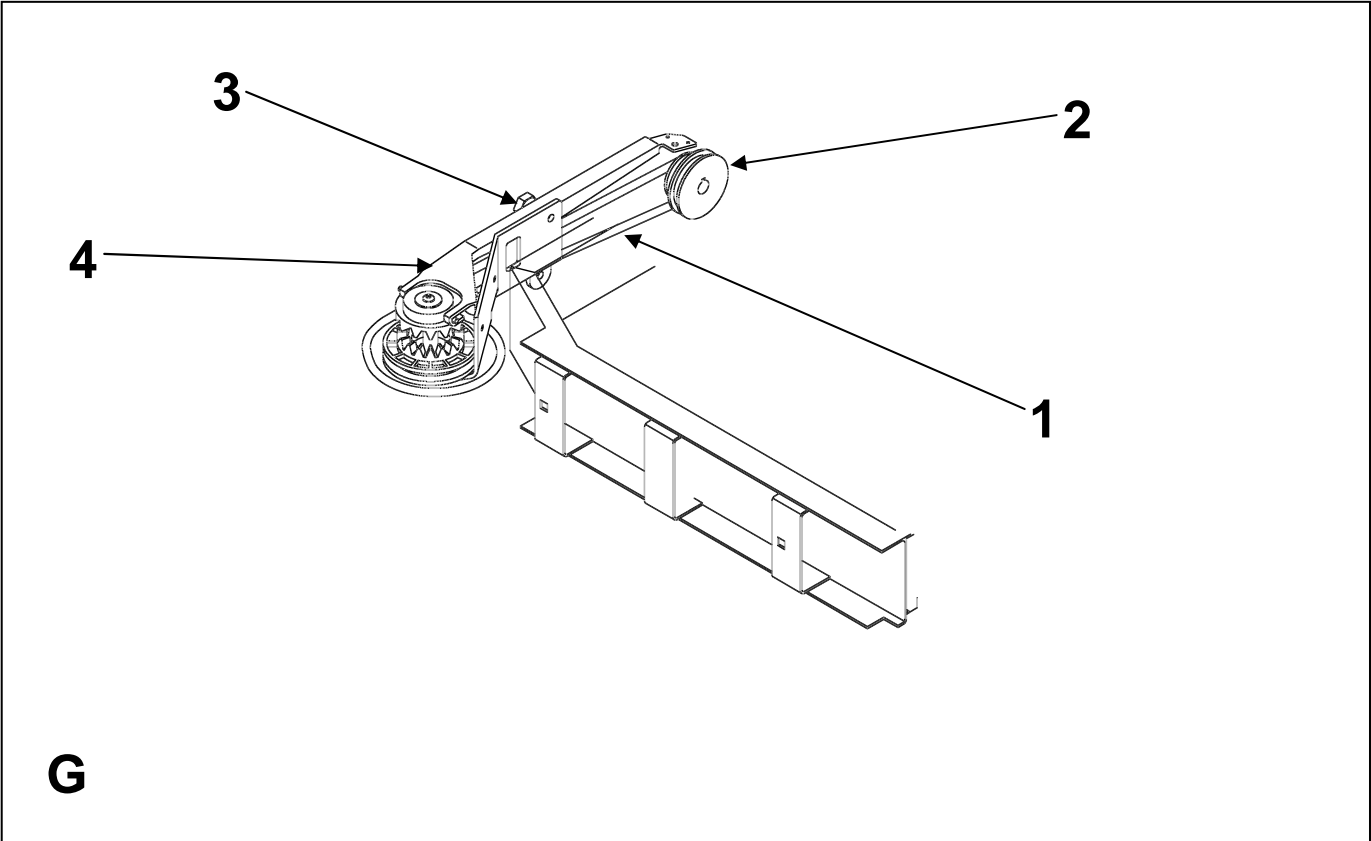

G

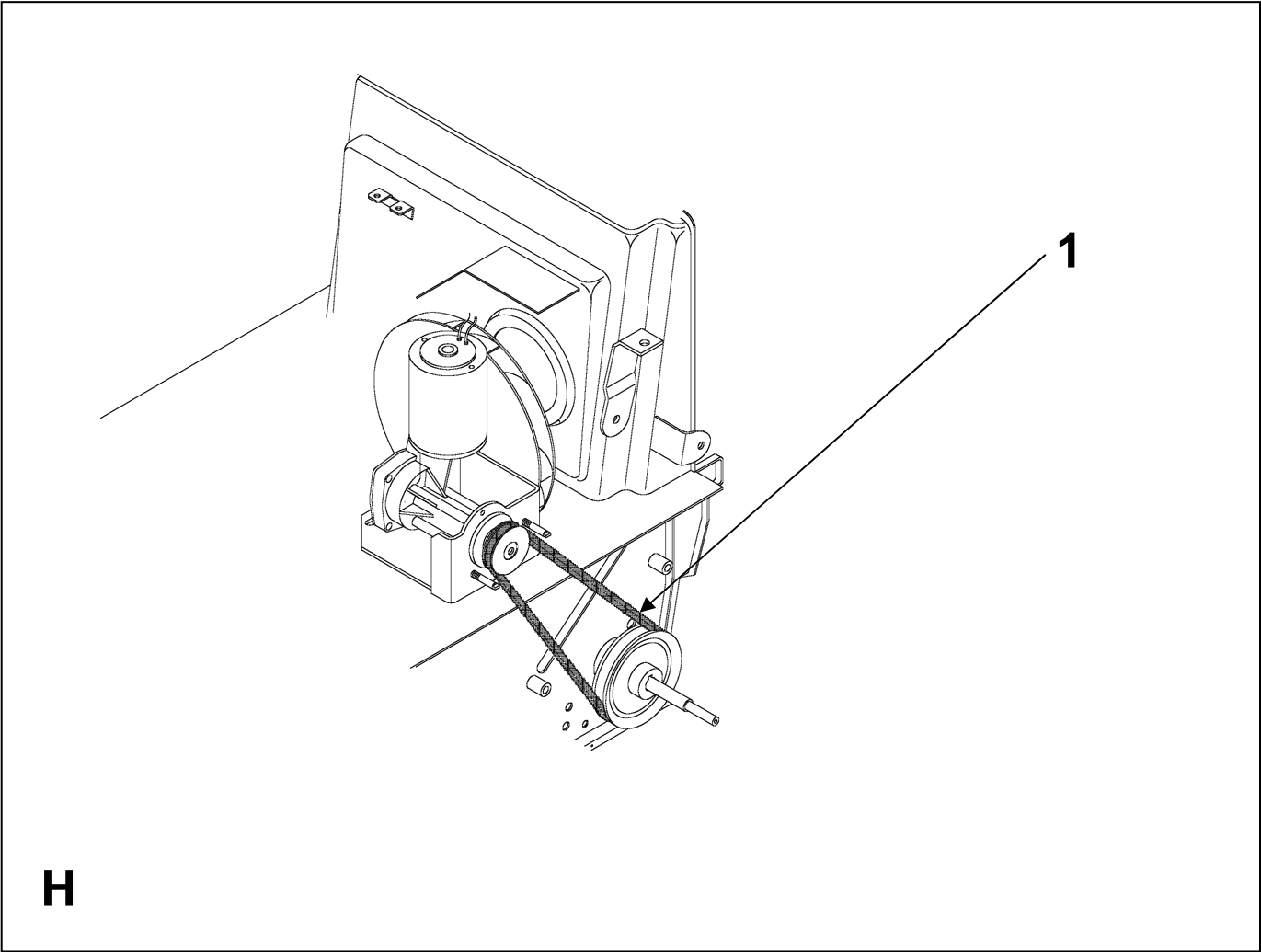

H

1

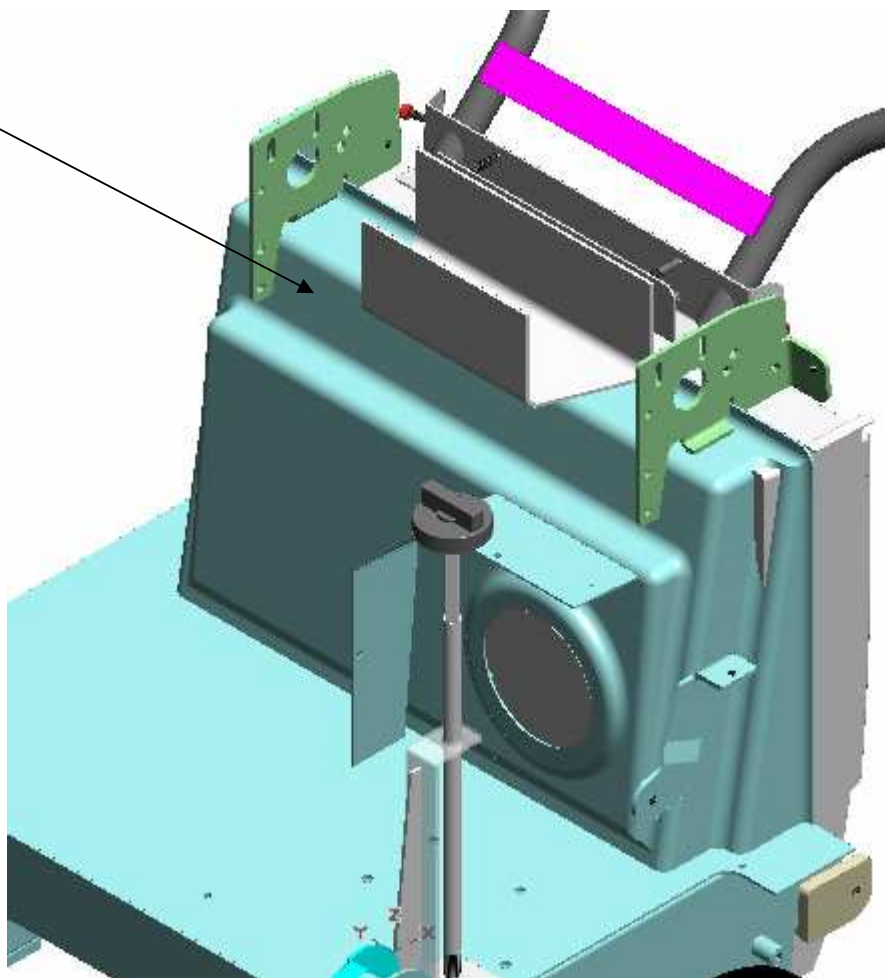

I

ENGLISH

(Translation of original instructions)

1. CONTENTS

1. CONTENTS	2
2. GENERAL INFORMATION	4
2.1. SCOPE OF THE MANUAL	4
2.2. DOCUMENTATION PROVIDED WITH THE MACHINE	5
3. TECHNICAL INFORMATION	5
3.1. GENERAL DESCRIPTION	5
3.2. LEGEND	5
3.3. DANGER ZONES	6
4. SAFETY INFORMATION	6
4.1. SAFETY REGULATIONS	6
5. HANDLING AND INSTALLATION	9
5.1. LIFTING AND TRANSPORTING THE PACKAGED MACHINE	9
5.2. CHECKS ON DELIVERY	9
5.3. UNPACKING	9
5.4. LIFTING AND TRANSPORTING THE MACHINE	10
6. PRACTICAL GUIDE FOR THE OPERATOR	10
6.1. CONTROLS – DESCRIPTION 512 – 712 RIDER	10
6.2. CONTROLS – DESCRIPTION 512 – 712	11
6.3. FITTING THE SIDE BRUSH	11
6.4. PREPARING THE MACHINE FOR WORK	12
6.4.1. Internal combustion engine: preparation	12
6.4.2. Batteries: installation and connection	12
6.4.3. Batteries: removal	13
6.4.4. The battery charger	13
6.4.5. Choosing the battery charger	13
6.4.6. Preparing the battery charger	13
6.5. WORKING	14
7. PERIODS OF INACTIVITY	17
8. MAINTENANCE INSTRUCTIONS	17
8.1. MAINTENANCE - GENERAL RULES	17
8.2. ROUTINE MAINTENANCE	17
8.2.1. <i>External side brushes: replacing</i>	17
8.2.2. <i>Rear bin: replacing</i>	18
8.2.3. <i>Centre brush: replacing</i>	18

8.2.4.	<i>Side brush: replacing</i>	18
8.2.5.	<i>Fuses: replacing</i>	18
8.2.6.	<i>Side brush belt: replacing</i>	18
8.2.7.	<i>Drive belt 512-712: replacing</i>	19
8.3.	REGULAR MAINTENANCE.....	19
8.3.1.	<i>Daily operations</i>	19
8.3.2.	<i>Weekly operations</i>	19
8.3.3.	<i>Six monthly operations</i>	19
9.	TROUBLESHOOTING	21
9.1.	HOW TO RESOLVE POSSIBLE PROBLEMS 512 – 712 RIDER	21
9.2.	HOW TO RESOLVE POSSIBLE PROBLEMS 512 – 712	23
9.3.	ALARMS DISPLAYED 512 – 712 RIDER	24
10.	SETTING THE CONTROL PANEL BOARD 512 – 712 RIDER	25

2. GENERAL INFORMATION



Read this manual carefully before carrying out any work on the machine¹.

2.1. Scope of the manual

This manual has been written by the Manufacturer and is an integral part of the machine.

It defines the purpose for which the machine has been designed and constructed and contains all the information required by operators.

In addition to this manual containing all user information, other publications are available providing specific information for maintenance personnel.

Constant respect for the instructions guarantees the safety of the operator and the machine, low running costs and high quality results and extends the working life of the machine. Failure to respect the instructions may lead to damage to the operator, machine, floor and environment.

To find the topic that interests you more rapidly, consult the list of contents at the beginning of the manual.

Parts of the text requiring special attention are highlighted in bold and preceded by the symbols illustrated and described here.

! DANGER

Indicates the need for attention in order to avoid a series of consequences which could cause death or damage to the health of the operator.

👉 IMPORTANT

Indicates the need for attention in order to avoid a series of consequences which could cause damage to the machine or work environment or financial loss.

i INFORMATION

Particularly important instructions.

In line with the company's policy of constant product development and updating, the Manufacturer reserves the right to make modifications without warning.

Although your machine may differ appreciably from the illustrations in this document, safety and the information contained in this manual are guaranteed. Identifying the machine

¹ The definition "machine" replaces the trade name covered by this manual..

The rating plate located as shown in fig. 1, ref. 1 provides the following information:

- model;
- power supply;
- total nominal power;
- serial number;
- year of fabrication;
- weight fully loaded;
- maximum slope;
- barcode with serial number;
- manufacturer's identification.

2.2. Documentation provided with the machine

- user manual;
- guarantee certificate;
- EC certificate of conformity.

3. TECHNICAL INFORMATION

3.1. General description

This machine is a motorised sweeper designed to sweep floors in civil and industrial premises.

The sweeper may be used to clean the residues from industrial processes, dust and dirt in general on all relatively even flat hard surfaces such as concrete, asphalt, porcelain stoneware, ceramic tiles, sheet metal, marble, embossed or smooth rubber or plastic mats indoors or outdoors.

3.2. Legend

The main parts of the machine are as follows (fig. A):

- front bin (fig. A / B, ref. 2)
- rear bin (fig. A / B, ref. 1)
- display (fig. A, ref. 3)
- centre brush (fig. A / B, ref. 4), the principal organ of the machine, transfers the dust and debris to the bin. Available in a range of hardnesses and with different bristles, according to the type of material to be picked up.
- side brush (fig. A / B, ref. 5), conveys the dust and debris, used exclusively to clean edges, corners and profiles.
- suction filter (fig. A / B, ref. 6), filters air drawn in by the suction fan.
- suction fan, enables the machine to sweep without raising dust.
- filter shaker, used to clean the suction filter.
- engine (**INTERNAL COMBUSTION ENGINE VERSION**)

- battery charger display (fig. A / B, ref. 7) (**OPTIONAL**)

3.3. Danger zones

A -**Control panel**: danger of short circuit.

B -**Centre brush**: danger due to brush rotation.

C -**Side brush**: danger due to brush rotation.

D -**Back/front wheels**: danger of crushing between the wheel and chassis.

E -**Motor compartment**: danger of short circuit between the poles of the battery (**BATTERY VERSION**), risk of serious burns when performing any maintenance with the engine off but not completely cold (**INTERNAL COMBUSTION ENGINE VERSION**).

4. SAFETY INFORMATION

4.1. Safety regulations



Read the "User manual" carefully before start-up and use, or before performing maintenance or any other work on the machine.

IMPORTANT

Rigorously respect all instructions in the Manual (in particular those relating to danger and important information) and on the safety plates fitted to the machine. The Manufacturer declines all liability for damage to people or things resulting from failure to observe the instructions.

The appliance must be used exclusively by persons trained in its use and/or who have demonstrated their ability and have been expressly instructed to use the appliance.

The machine must not be used by minors.

The machine must not be used for purposes other than those for which it was expressly designed. Scrupulously respect all safety standards and conditions applicable to the type of building in which the machine is to be operated (eg: pharmaceutical companies, hospitals, chemicals, etc).

Do not use the machine in places with inadequate lighting or explosive atmospheres, on public roads, in the presence of dirt hazardous to health (dust, gas, etc) and in unsuitable environments.

The machine is designed for use at temperatures of between +4°C and +35°C. When the machine is not being used, the temperature range is +0°C and +50°C.

The machine is designed to work in a humidity of between 30% and 95%.

Never pick up flammable liquids or explosives (eg. petrol, fuel oil, etc), acids and solvents

(eg. paint solvents, acetone etc.). Never pick up flaming or incandescent objects.

Never use the machine on slopes or ramps of more than 2%. In the case of slight slopes, do not use the machine transversally, always manoeuvre with care and do not reverse. When transporting the machine on steeper ramps or slopes, take the utmost care to avoid tipping up and/or uncontrolled acceleration. .

Never park the machine on a slope.

The machine must never be left unattended with the motor or engine on. Before leaving it, turn the motor or engine off, make sure it cannot move accidentally.

Always pay attention to other people, children in particular, present in the place where you are working.

Never use the machine to transport people or things or to tow anything not permitted by the manufacturer. Do not tow the machine.

Never rest objects of any weight on the machine for any reason.

Never obstruct ventilation and heat dispersion slits.

Never remove, modify or circumvent safety devices.

Numerous unpleasant experiences have shown that a wide range of personal objects may cause serious accidents. Before beginning work, remove jewellery, watches, ties, etc.

The operator must always use personal protection devices: protective apron or overalls, non-slip waterproof shoes, rubber gloves, protective goggles and ear protectors and mask to protect the respiratory tract.

Keep the hands away from moving parts.

In the case of malfunction and/or faulty operation, turn the machine off immediately and do not tamper. Contact a service centre authorised by the Manufacturer.

All maintenance operations must be performed in an adequately lit place.

All work on the electrical system and all maintenance and repair operations other than those explicitly described in this manual must be performed by specialised personnel expert in the sector only.

Only original accessories and spare parts supplied by the Manufacturer may be used in order to guarantee safe problem-free operation of the machine. Never use parts removed from other machines or from other kits.

This machine has been designed and constructed to provide ten years' service from the fabrication date shown on the rating plate. After this time, whether the machine has been used or not, it should be disposed of according to current legislation in the country in which it is used:

- the product is classified as WEEE type special waste and is covered by the requisites of the new environmental protection regulations (2002/96/CE WEEE). It must be disposed of separately from ordinary waste in compliance with current legislation and standards.



Special waste. Do not dispose of with ordinary waste.

Alternatively the machine must be returned to the Manufacturer for a complete overhaul.

If you decide to stop using the machine, you are recommended to remove the batteries and dispose of them at an authorised collection centre.

You should also make sure that all parts of the appliance which could represent a hazard, particularly to children, are made safe.

5. HANDLING AND INSTALLATION

5.1. Lifting and transporting the packaged machine

IMPORTANT

During all lifting operations, make sure the packaged machine is firmly anchored to avoid it tipping up or being accidentally dropped.

Always load/unload lorries in adequately lit areas.

The machine, packaged on a wooden pallet by the Manufacturer, must be loaded using suitable equipment (see EC Directive 89/392 and subsequent amendments and/or additions).

A fork lift truck must always be used to lift the packaged body of the machine. Handle with care to avoid knocking or overturning the machine.

5.2. Checks on delivery

When the carrier delivers the machine, make sure the packaging and machine are both whole and undamaged. If the machine is damaged, make the carrier is aware of the damage and before accepting the goods, reserve the right (in writing) to request compensation for the damage.

5.3. Unpacking

IMPORTANT

When unpacking the machine, the operator must be provided with the necessary personal protection devices (gloves, goggles, etc) to limit the risk of accident.

Unpack the machine as follows:

- cut and remove the plastic straps using scissors or nippers;
- remove the cardboard;
- depending on the model, remove the metal brackets or cut the plastic straps fixing the machine chassis to the pallet;
- using a sloping ramp, push the machine backwards off the pallet;
- move the machine away from the packaging.

The packaging may be kept as it can be reused to protect the machine if it is moved to another site or to a repair workshop.

Otherwise it must be disposed off in compliance with current legislation.

5.4. Lifting and transporting the machine

IMPORTANT

All phases must be performed in an adequately lit room and adopting the safety measures most appropriate to the situation.

The operator must always use personal protection devices.

To load the machine onto a means of transport, proceed as follows:

- Empty the bin
- place the machine on the pallet and fix it with plastic straps or metal brackets;
- lift the pallet (with the machine) using a fork lift truck and load it onto the means of transport;
- anchor the machine to the means of transport with cables connected to the pallet and machine itself.

6. PRACTICAL GUIDE FOR THE OPERATOR

6.1. Controls – Description 512 – 712 RIDER

With reference to fig. C, the machine has the follow controls and indicator lights:

On/OFF switch (fig. C, ref. 1): turns the machine on and off

Emergency button (fig. A, ref. 16): enables/disables all functions of the machine.

Suction button (fig. C, ref. 2): enables/disables the suction function.

Brush button (fig. C, ref. 3): enables/disables brush operation.

Filter shaker button (fig. C, ref. 4): enables the filter shaker.

Battery charge LED (fig. C, ref. 5): 3 LEDs indicating the battery charge:

green light battery fully charged

yellow light battery almost flat, recharge

red light battery flat

Centre brush pressure LED (fig. C, ref. 6): 6 LEDs indicating the pressure of the centre brush on the work surface. The pressure exerted by the brush on the floor is calculated by means of the current absorbed by the centre brush motor:

green lights, light pressure

yellow light, medium pressure

red light, heavy pressure

If the red light (LED 6) comes on, all LEDs start flashing.

Two minutes after the red light comes on, the brush function is shut down automatically.

Centre brush pressure regulation handle (fig. A, ref. 8): regulates the pressure of the

brush on the floor.

Accelerator knob (fig. A, ref. 9), sets the speed of the machine.

Front flap raising knob (fig. A, ref. 10), raises the front flap to collect bulky debris.

Side brush lifting lever (fig. A, ref. 11): raises and lowers the side brush.

Direction selector (fig. C, ref. 7): sets movement of the machine to forwards or reverse

Display (fig. C, ref. 8). displays alarm codes

Brake (fig. A, ref. 12): parking brake (ACTIVATED VIA THE WHITE LEVER) and service brake

START generator (fig. A, ref. 17): Electric starting internal combustion engine

6.2. Controls – Description 512 – 712

With reference to fig. C, the machine has the follow controls and indicator lights:

On/OFF switch (fig. C, ref. 1): turns the machine on and off

Suction button (fig. C, ref. 2): enables/disables the suction function.

Filter shaker button (fig. C, ref. 4): enables the filter shaker.

Battery charge LED (fig. C, ref. 5): 3 LEDs indicating the battery charge:

green light battery fully charged

yellow light battery almost flat, recharge

red light battery flat

Centre brush pressure regulation handle (fig. B, ref. 8): regulates the pressure of the brush on the floor.

Drive knob (fig. B, ref. 9), enables the drive of the machine.

Front flap raising knob (fig. B, ref. 10), raises the front flap to collect bulky debris.

Side brush lifting lever (fig. B, ref. 11): raises and lowers the side brush.

Brake (fig. B, ref. 12): parking brake

Suction LED (fig. C, ref. 9) indicates the suction status ON/OFF

6.3. Fitting the side brush



IMPORTANT

This operation must be performed with the machine off and key removed

Proceed as follows (fig. D):

- Lift the front of the machine
- Fit the brush and fix it in place with the washer and screw provided (fig. D, ref. 1).
- Unscrew the two screws (fig. E, ref. 1), adjust the height of the brush and tighten the screws again.

6.4. Preparing the machine for work

IMPORTANT

Before starting work, wear overalls, ear protectors, non-slip shoes, mask to protect the respiratory tract, gloves and all other personal protection devices necessitated by the work environment.

6.4.1. Internal combustion engine: preparation

Read the engine instruction manual annexed to the machine manual carefully and check the level of oil in the engine. If low, top up wearing protective gloves.

Fill with petrol.

6.4.2. Batteries: installation and connection

The batteries are normally supplied filled with acid and ready for use.

If the batteries are dry, before mounting them on the machine, proceed as follows:

- remove the caps and fill all elements with specific sulphuric acid solution until the plates are entirely covered (this requires at least a couple of passes for each element);
- leave for 4-5 hours to allow the air bubbles to come to the surface and the plates to absorb the electrolyte;
- make sure the level of electrolyte is still above the plates and if necessary top up with sulphuric acid solution;
- close the caps;
- mount the batteries on the machine (following the procedure described below).

Before starting up the machine the first time, charge the batteries.

! DANGER

Check that all switches on the control panel are in the "0" (off) position.

Make sure you connect the terminals marked with a "+" to the positive poles of the battery. Do not check the battery charge by sparking.

Meticulously follow the instructions given below as short circuiting the batteries could cause them to explode.

- Rotate the top cowling through 90° towards the back of the machine
- Place the battery/ies into the compartment.
- Connect the battery/ies.

IMPORTANT

**Mount the batteries on the machine using means suitable for their weight.
The positive and negative poles have different diameters.**

- Rotate the top cowling
- When using the machine, follow the instructions below.

6.4.3. Batteries: removal

! DANGER

When removing the batteries, the operator must be equipped with suitable personal protection devices (gloves, goggles, overalls, safety shoes, etc) to reduce the risk of accidents. Make sure the switches on the control panel are in the "0" position (off) and the machine is turned off. Keep away from naked flames, do not short circuit the battery poles, do not cause sparks and do not smoke. Proceed as follows:

- disconnect the battery wiring and bridge terminals from the battery poles.
- if necessary, remove the devices fixing the battery to the base of the machine.
- lift the batteries from the compartment using suitable lifting equipment.

6.4.4. The battery charger

IMPORTANT

Never allow the batteries to become excessively flat as this could damage them irreparably.

6.4.5. Choosing the battery charger

Make sure the battery charge is compatible with the batteries to be charged:

tubular lead batteries: you are recommended to use an automatic battery charger. However, you should always consult the battery charger manufacturer and manual to confirm the choice.

gel batteries: use a charger specific for this type of battery.

6.4.6. Preparing the battery charger

If you wish to use a battery charger not provided with the machine, you must fit it with the connector supplied with the machine.

To install the connector, proceed as follows:

- remove about 13 mm of protective sheath from the red and black wires of the battery charger;
- insert the wires into the connector contacts and squeeze them forcefully with suitable pliers;
- respect the polarity (red wire + black wire –) when inserting the wires into the connector.
- Insert the wired-up connector into the connector in the machine compartment.

6.5. Working

i INFORMATION

If you are using the machine for the first time, we recommend trying it on a large obstacle-free surface first to acquire the necessary familiarity.

Starting up/use 512 – 712 RIDER:

i INFORMATION

The seat (fig. A, ref. 15) has a safety sensor which allows the machine to move only when the operator is seated.

- Prepare the machine as described in the above paragraph.
- Lift the side brush using the lifting lever (fig. A, ref. 11).
- Turn the key switch (fig. C, ref. 1) to the "1" position.
- Check the LEDs (fig. C, ref. 5) to make sure the battery/ies is fully charged. If not, charge the batteries (**BATTERY version**).
- Open the cowling and use the internal combustion engine starting handle. When the engine is cold, you also need to use the choke (**INTERNAL COMBUSTION ENGINE with manual pull start**).
- Press the internal combustion engine electric starting button (fig. A, ref. 17) (**INTERNAL COMBUSTION ENGINE with electric starting**).
- Press the brush button (fig. C, ref. 3), when the brushes are active, the LED on the button comes on. Pressing it again stops the brushes, the suction motor comes on automatically.
- Use the accelerator knob to activate the drive (fig. A, ref. 9)

i INFORMATION

To set the maximum operating speed, proceed as follows:

1. With the machine off, turn the key switch (fig. C, ref. 1) to the "1" position.
2. Move forwards with the machine using the accelerator knob (fig. A, ref. 9) to select the required maximum speed, then move the drive selector (fig. C, ref. 7) to the centre position. Memorising of the speed is indicated by a beep.

To reset the maximum operating speed set by the manufacturer, turn the machine on and off using the key switch (fig. C, ref. 1) or repeat the instructions in point 2, turning the accelerator knob (fig. A, ref. 9) as far as it will go (**MAX. SPEED**).

Reverse speed cannot be changed.

- Adjust pressure of the centre brush on the floor using the knob (fig. A, ref. 8) according

to the type of floor and dirt to be picked up. Turn it clockwise to increase pressure and anticlockwise to reduce pressure on the work surface.

- Lower the side brush using the lever (fig. A, ref. 11).
- Start cleaning, manoeuvring the handgrip with the hands and acting on the drive control.

Starting up/use 512 - 712:

- Prepare the machine as described in the above paragraph.
- Lift the side brush using the lifting lever (fig. B, ref. 11).
- Turn the key switch (fig. C, ref. 1) to the "1" position.
- Check the LEDs (fig. C, ref. 5) to make sure the battery/ies is fully charged. If not, charge the batteries (**BATTERY version**).
- Open the cowling and use the internal combustion engine starting handle. When the engine is cold, you also need to use the choke (**INTERNAL COMBUSTION ENGINE with manual pull start**).
- Use the lever to activate the drive (fig.C, ref. 2)
- Press the suction button (fig.B, ref. 9).
- Adjust pressure of the centre brush on the floor using the knob (fig. B, ref. 8) according to the type of floor and dirt to be picked up. Turn it clockwise to increase pressure and anticlockwise to reduce pressure on the work surface.
- Lower the side brush using the lever (fig. B, ref. 11).
- Start cleaning, manoeuvring the handgrip with the hands and acting on the drive control.

IMPORTANT

To avoid damaging the surface of the floor to be treated, avoid rotating the brushes with the machine stationary.

IMPORTANT

Do not pick up wire, string or plastic straps.



IMPORTANT IMPORTANT

Each 30 minutes of work, activate the filter shaker button (fig. C, ref. 4) for 30 seconds to clean the suction filter. During this operation, the suction fan shuts off automatically.

IMPORTANT

Avoid passing over puddles. If the work surface is wet, you can use the machine only by turning off the suction fan (fig. C, ref. 2) as damp/wet dirt reduces the performance of the suction filter.

Emptying the debris bin:

Before emptying the bin, make sure all machine functions are turned off;

IMPORTANT

When emptying the bin, always wear a mask to protect the respiratory tract from the dust which is always present during this operation.

Front bin:

- Use the handle to release the bin (fig. B, ref. 12) **512-712**.
- Use the handle to release the bin (fig. B, ref. 13) **512-712 RIDER**.
- Grip the bin and slide it out
- Empty the bin.
- Replace the bin.
- Use the handle to block the bin in place (fig. B, ref. 12) **512-712**
- Use the handle to block the bin (fig. A, ref. 13) **512-712 RIDER**

Rear bin:

- Release the bin by lifting and turning the two clips (fig. B, ref. 13) **512-712**.
- Release the bin by lifting and turning the two clips (fig. A, ref. 14) **512-712 RIDER**.
- Grip the bin and remove it from the machine.
- Empty the bin.
- Replace the bin.
- Block the bin in place by turning the two clips and pressing them when in position.

Stopping:

- Move the machine to the parking area
- Stop the machine by releasing the handle (fig. B, ref. 9) **512-712**, releasing the accelerator knob (fig. A, ref. 9) **512-712 RIDER**.
- Turn off the brushes using the button (fig. C, ref. 3) **512-712 RIDER** .
- Stop suction (fig. C, ref. 9) **512-712**
- Lift the side brush using the lever (fig. A/B, ref. 11).
- Turn the key switch (fig. C, ref. 1) to the "0" position.

7. PERIODS OF INACTIVITY

- Disconnect the battery. To optimise the working life of the battery, it should be charged every 30/40 days. If the level of solution is low, top up with distilled water.
- Empty the bins.
- Clean the machine in general.
- Clean the suction filter.

8. MAINTENANCE INSTRUCTIONS

! DANGER

Maintenance on the electrical circuit and all other operations not explicitly described in this manual must be performed by specialised personnel only, in compliance with current safety legislation and as described in the maintenance manual.

For all maintenance on the engine, see the instruction book.

! DANGER

Never perform any maintenance operations without first disconnecting the batteries from the machine's electrical circuit.

8.1. Maintenance - General rules

Performing regular maintenance according to the Manufacturer's instructions improves performance and extends the working life of the machine.

When cleaning the machine, respect the following:

1. avoid the use of high pressure washers. Water could penetrate the electrical compartment or motors leading to damage or the risk of short circuit;
2. do not use steam to avoid the heat warping plastic parts;
3. do not use hydrocarbons or solvents as they could damage the cowling and rubber parts.

8.2. Routine maintenance

8.2.1. External side brushes: replacing

- Rotate the cowling.
- Remove the back wheels
- Unscrew the screws fixing the flap to the chassis (fig. F, ref. 1).
- Replace with new flaps.

8.2.2. Rear bin: replacing

- Remove the back wheels
- Remove the rear bin
- Unscrew the two pins fixing the flap (fig. F, ref. 3).
- Grip the flap and pull (fig. F, ref. 4)
- Replace the flap, insert the two pins in the relative holes
- Screw up the fixing pins and assemble the machine.

8.2.3. Centre brush: replacing

- Remove the front bin (fig. A / B, ref. 2)
- Unscrew the screws fixing the brush to the shaft.
- Remove the brush
- Replace the brush making sure the orientation of the bristles is correct.

8.2.4. Side brush: replacing

- Lift the front of the machine
- Unscrew the screw (fig. D, ref. 1), remove the worn brush
- Install the new brush and fix it with the screw (fig. D, ref. 1).
- Unscrew the two screws (fig. E, ref. 1), adjust the height of the brush and tighten the screws.

IMPORTANT

Never use a fuse with a higher amperage than specified.

If a fuse continues to blow, the fault in the wiring, boards (if present) or motors must be identified and repaired. Have the machine checked by qualified personnel.

8.2.5. Fuses: replacing

- Turn the key switch (fig. C, ref. 1) to the "0" position.
- Rotate the cowling to access the machine compartment
- Remove the fuse holder cover
- Check the fuses.
- Replace with a new fuse.
- Close the cover again

Fuse table: For the complete fuse table, see the spare parts catalogue.

8.2.6. Side brush belt: replacing

- Rotate the top cowling.
- Remove the pulley (fig. G, ref. 2) belt (fig. G, ref. 1)
- Unscrew the fixing pin (fig. G, ref. 3) and side arm hooks (fig. G, ref. 4) from the idle toothed ring.

- Remove the belt (fig. G, ref. 1) from the side arm (fig. G, ref. 4)
- Replace the belt
- Attach the side arm (fig. G, ref. 4) to the idle toothed wheel again.
- Screw up the pin (fig. G, ref. 3).
- Fit the belt (fig. G, ref. 1) onto the pulley (fig. G, ref. 2)

8.2.7. Drive belt 512-712: replacing

- Rotate the cowling.
- Remove the belt (fig. H, ref. 1) from the groove of the pulleys.
- Fit the new belt (fig. H, ref. 1) onto the pulleys.

8.3. Regular maintenance

8.3.1. Daily operations

- empty the bins.
- make sure there are no wires or straps rolled around the centre brush.
- recharge the batteries according to the procedure described.

8.3.2. Weekly operations

- check for wear of the FLAPS. If necessary, replace.
- Check the condition of the suction air filter and make sure it is undamaged. If necessary, replace.
- check the level of battery electrolyte and top up with distilled water if necessary.

8.3.3. Six monthly operations

- Have the electricity circuit checked by qualified personnel.

TABLE OF MAINTENANCE

- A : On receipt
 B : Every 10 hours
 C : Every 50 hours
 D : Every 100 hours

CHECK	A	B	C	D
Centre brush: make sure there are no straps or nylon cord wrapped around the brush. If necessary, remove		◆		
Centre brush: check wear of the brush			◆	
Side brushes: check wear of the brushes			◆	
Flap / Bin gasket: check wear of the flaps and gaskets			◆	
Dust filter: check that the filter is undamaged and clean			◆	
Tyres: check that the tyres are in good condition and without cuts at the sides				◆
Battery: check the level of acid in the batteries	◆	◆		
Internal combustion engine: replace the engine oil	See engine instructions			
Internal combustion engine: replace oil filter	See engine instructions			
Internal combustion engine: replace air filter	See engine instructions			
Internal combustion engine: clean air filter	See engine instructions			
Internal combustion engine: check oil level	See engine instructions			
General control: check that nuts and screws are tight			◆	

9. TROUBLESHOOTING

9.1. How to resolve possible problems 512 – 712 RIDER

PROBLEM	CAUSE	SOLUTION
The machine does not function	Battery disconnected	Connect the battery to the machine
	The battery is flat.	Recharge the battery
	The key switch (fig. C, ref. 1) is in the 0 position	Turn the key switch (fig. C, ref. 1) to the "1" position.
	Emergency button pressed (fig. A ref. 16)	Release the emergency button (fig. A ref. 16)
	Main solenoid switch faulty.	Replace solenoid switch
	Fuse blown	Replace fuse
	No petrol	Fill the machine
Suction motor does not function	Fuse blown	Replace fuse
	Fan switch on OFF (fig. C, ref. 2)	Press the fan switch (fig. C, ref. 2)
	Suction relay faulty	Replace relay
	Motor malfunction	Replace the motor
The centre brush does not turn	Fuse blown	Replace fuse
	Brush switch not pressed (fig. C, ref. 3)	Press the brush switch (fig. C, ref. 3)
	Suction relay faulty	Replace relay
	Led 6 (red) on (fig. C, ref. 6) heavy brush pressure	Reduce the pressure of the centre brush on the work surface.
	Motor malfunction	Replace the motor
Filter shaker not working	Fuse blown	Replace fuse
	Filter shaker relay faulty	Replace relay
	Filter shaker switch not pressed (fig. C, ref. 4)	Press the filter shaker switch (fig. C, ref. 4)
	Filter shaker motor faulty	Replace filter shaker motor
Side brush does not turn	Damaged belt	Replace the belt
The machine raises dust	Side flaps damaged	Replace flaps
	Bin full	Empty the bin
Dust comes out of the fan	Filter incorrectly positioned	Remove the filter and replace correctly
	Worn gaskets	Replace gaskets
Drive motor does not work	Fuse blown	Replace fuse
	Microswitch under seat not pressed	Sit correctly on the seat

	Drive motor overheated	Turn off the machine and wait for a few minutes
	Heat sensor damaged	Replace heat sensor
	Damaged drive board	Replace drive board
	Motor malfunction	Replace the motor
	Accelerator potentiometer malfunction	Replace potentiometer

9.2. How to resolve possible problems 512 – 712

PROBLEM	CAUSE	SOLUTION
The machine does not function	Battery disconnected	Connect the battery to the machine
	The battery is flat.	Recharge the battery
	The key switch (fig. C, ref. 1) is in the 0 position	Turn the key switch (fig. C, ref. 1) to the "1" position.
	No petrol	Fill the machine
Suction motor does not function	Fuse FU4 blown	Replace fuse FU4
	Fan switch on OFF (fig. C, ref. 2)	Press the fan switch (fig. C, ref. 2)
	Motor malfunction	Replace the motor
The centre brush does not turn	Fuse blown	Replace fuse
	Motor malfunction	Replace the motor
Filter shaker not working	Filter shaker switch not pressed (fig. C, ref. 4)	Press the filter shaker switch (fig. C, ref. 4)
	Filter shaker motor faulty	Replace filter shaker motor
Side brush does not turn	Damaged belt	Replace the belt
The machine raises dust	Side flaps damaged	Replace flaps
	Bin full	Empty the bin
Dust comes out of the fan	Filter incorrectly positioned	Remove the filter and replace correctly
	Worn gaskets	Replace gaskets
Drive motor does not work 512-712	Fuse blown	Replace fuse
	Motor malfunction	Replace the motor

9.3. Alarms displayed 512 – 712 RIDER

- Acc Accelerator.** Appears if the accelerator knob (fig. A, ref. 9) is activated before the machine is turned on or after the emergency button has been reset. Release the accelerator knob then action again
- Pot Potentiometer.** Appears if the speed potentiometer malfunctions or is faulty. The drive has stopped. Release the knob then action again. If the message continues, the potentiometer could be faulty.
- Lim Limitation.** Appears when a mosfet internal thermal limitation problem occurs. The drive has stopped. Release the accelerator knob then action again. If the problem continues, wait for a few minutes.
- Hot Overheating.** When the motor overheat sensor trips, wait for a few minutes for the motor to cool down.
- MoS Mosfet.** Appears when the mosfet is in short circuit. All machine functions are shut down.
- bLt Drive block.** Appears when the battery voltage is too low. Recharge the batteries.
- AcS Brush control fault.** Appears when there is a fault in the relay controlling the brush. Turn off the brush motor then turn on again. If the message does not disappear, the relay may be disconnected or the control element on the board may be faulty.
- AcA Suction control fault.** Appears when there is a fault in the relay controlling the suction. Turn off the suction motor then turn on again. If the message does not disappear, the relay may be disconnected or the control element on the board may be faulty.
- NoFR General solenoid switch KM1 fault.** Appears when the general solenoid switch is faulty. Turn the machine off then on again. If the message does not disappear, the solenoid switch may be faulty disconnected or disconnected, or the control element on the board may be faulty.

10. SETTING THE CONTROL PANEL BOARD 512 – 712 RIDER

i INFORMATION

If the control board is replaced, make sure the dip switches are set according to the type of machine being used.

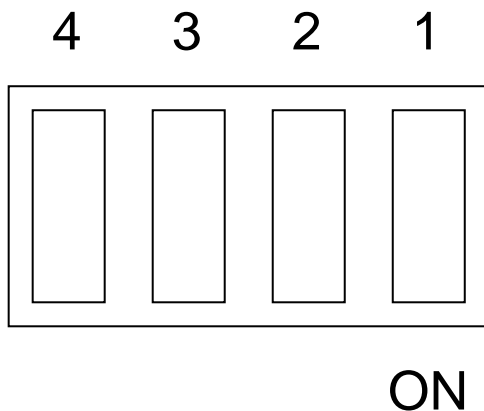

- SW1 (**ON**) = 12 V machine power supply
- SW2 (**ON**) = GEL batteries
- SW3 (**ON**) = "RIDER" version
- SW4 (**ON**) = Internal combustion engine