



Clemas & Co Ltd

Industrial Cleaning Equipment
Sales - Hire - Service

CT90 SCRUBBER DRYER OPERATOR MANUAL



Clemas & Co. Unit 5 Ashchurch Business Centre, Alexandra Way, Tewkesbury,
Gloucestershire, GL20 8NB.

Tel: 01684 850777

Fax: 01684 850707

Email: info@clemas.co.uk

Web: www.clemas.co.uk

TECHNICAL SPECIFICATIONS
TECHNISCHE DATEN
DONNEES TECHNIQUES
CARACTERÍSTICAS TÉCNICAS
CARATTERISTICHE TECNICHE
TECHNISCHE GEGEVENS

CT90				
		60BT	70BT	85BT
Cleaned track width Bearbeitungsbreite Largeur nettoyable Ancho recorrido limpido Larghezza pista pulita Werkbreedte	mm	614	678	810
Squeegee width Saugfußbreite Largeur suceur Ancho squeegee Larghezza squeegee Breedte zuigrubber	mm	816	942	942
Hourly performance Arbeitsleistung pro stende Rendement horaire Rendimiento orario Rendimento orario Rendement per uur	m ² /h	2579	2848	3402
Number of brushes Anzahl der Bürsten Nombre de brosses Número cepillos Numero spazzole Aantal borstels	n°	2	2	2
Brush diameter Durchmesser der Bürsten Diamètre de la brosse Diámetro cepillo Diametro spazzola Doorsnede borstel	mm	310	345	410
Max brush pressure Max. Bürstendruck Pression brosses max Presión cepillo max Pressione spazzole max Max. borsteldruk	gr/cm ²	31,5	23,58	21,79
Brush rotation speed Geschwindigkeit der Bürstendrehung Vitesse de rotation de la brosse Velocidad rotación del cepillo Velocità rotazione spazzola Draaisnelheid borstel	g/1'	215	215	215
Brush motor power Nennleistung des Bürstenmotors Puissance du moteur de la brosse Potencia motor del cepillo Potenza motore spazzola Vermogen borstelmotor	W	300	300	300
Drive control Antrieb Traction Tracción Trazione Aandrijving	/	Electronic	Electronic	Electronic
Drive motor rated power Nennleistung des Antriebsmotor Puissance nominale du moteur de traction Potencia nominal motor tracción Potenza nominale motore trazione Nominaal vermogen aandrijfmotor	W	180	180	180
Maximum speed Max. Geschwindigkeit Vitesse maxi Velocidad máxima Velocità massima Max. snelheid	Km/h	4,2	4,2	4,2
Suction motor power Nennleistung des Saugmotors Puissance du moteur d'aspiration Potencia motor de aspiración Potenza motore aspirazione Vermogen zuigmotor	W	480	480	480

Solution tank Lösungstank Réservoir de la solution Tanque de la solución Serbatoio soluzione Schoonwatertank	l	85	85	85
Recovery tank Schmutztank Réservoir de récupération Tanque de recuperación Serbatoio recupero Vuilwatertank	l	90	90	90
Wheel diameter Durchmesser der Antriebsräder Diamètre des roues Diámetro ruedas Diametro ruote Doorsnede wielen	mm	200	200	200
Net weight without batteries Nettogewicht ohne Batterien Poids net sans batteries Peso neto sin baterías Peso netto senza batterie Netto gewicht zonder batterijen	Kg	97,6	98,4	104
Number of batteries Anzahl der Batterien Nombre de batteries Número baterías Numero batterie Aantal batterijen	n°	4	4	4
Series battery voltage Spannung der Serienbatterien Voltage des batteries en série Tensión baterías en serie Tensione batterie in serie Spanning seriebatterijen	V	24	24	24
Single battery capacity Kapazität der einzelnen Batterie Capacité de chaque batterie Capacidad batería individual Capacità singola batteria Capaciteit afzonderlijke batterij	Ah (5h) Ah(20h)	180 200	180 200	180 200
Single battery weight Gewicht der einzelnen Batterie Poids de chaque batterie Peso batería individual Peso singola batteria Gewicht afzonderlijke batterij	Kg	32	32	32
Power supply cable length Länge des Speisekabels Longueur du câble d'alimentation Largo cable de alimentación Lunghezza cavo alimentazione Lengte netsnoer	mm	/	/	/
Power supply voltage Speisungsspannung Voltage d'alimentation Tensión de alimentación Tensione alimentazione Voedingspanning	V	/	/	/
Power supply frequency Speisungsfrequenz Fréquence d'alimentation Frecuencia de alimentación Frequenza alimentazione Voedingsfrequentie	Hz	/	/	/
Battery compartment size (length, width, height) Maße des Batterieabteils (Länge, Breite, Höhe) Dimensions du coffet des batteries (longueur, largeur, hauteur) Dimensión compartimento baterías (largo, ancho, alto) Dimensione vano batterie (lunghezza, larghezza, altezza) Afmetingen batterijvak (lengte, breedte, hoogte)	mm	525	390	300
Machine size (length, width, height) Maße der Maschine (Länge, Breite, Höhe) Dimensions de la machine (longueur, largeur, hauteur) Dimensiones de la máquina (largo, ancho, alto) Dimensioni macchina (lunghezza, larghezza, altezza) Machineafmetingen (lengte, breedte, hoogte)	mm X/Y/Z	1328x 680x 1025	1358x 748x 1025	1446x 893x 1025

Dimensions of packing (length, width, height) Maße der Verpackung (Länge, Breite, Höhe) Dimensions de l'emballage (longueur, largeur, hauteur) Dimensiones del embalaje (largo, ancho, alto) Dimensioni imballo (lunghezza, larghezza, altezza) Afmetingen verpakking (lengte, breedte, hoogte)	mm	1780x 930x 1290	1780x 930x 1290	1780x 930x 1290
Sound Pressure Schalldruck Pression Sonore Presion Sonora Pressione Sonora Geluidsdruk				
Sound Power Schalleistung Puissance Sonore Potencia Sonora Potenza Sonora Geluidsvermogen				
Vibration Level (arm) Schwingungspegel (arm) Niveau de Vibrations (bras) Nivel de Vibraciones (brazo) Livello Vibrazioni (braccio) Trillingsniveau (arm)				
Vibration Level (hand-arm) Schwingungspegel (hand-arm) Niveau de Vibrations (main-bras) Nivel de Vibraciones (mano-brazo) Livello Vibrazioni (mano-braccio) Trillingsniveau (hand-arm)				

Tab. C **Data can be changed without notice.**
Deiese Daten können ohne vorherige Benachrichtigung geändert werden.
Données techniques pouvant changer sans préavis.
Los datos pueden variar sin aviso previo.
Dati soggetti a variazioni senza preavviso.
Deze gegevens kunnen zonder voorafgaande kennisgeving veranderd worde

**MACHINE SIZE - MASSE DER MASCHINE
DIMENSIONS DE LA MACHINE
DIMENSIONES DE LA MÁQUINA - DIMENSIONI MACCHINA
MACHINEAFMETINGEN**

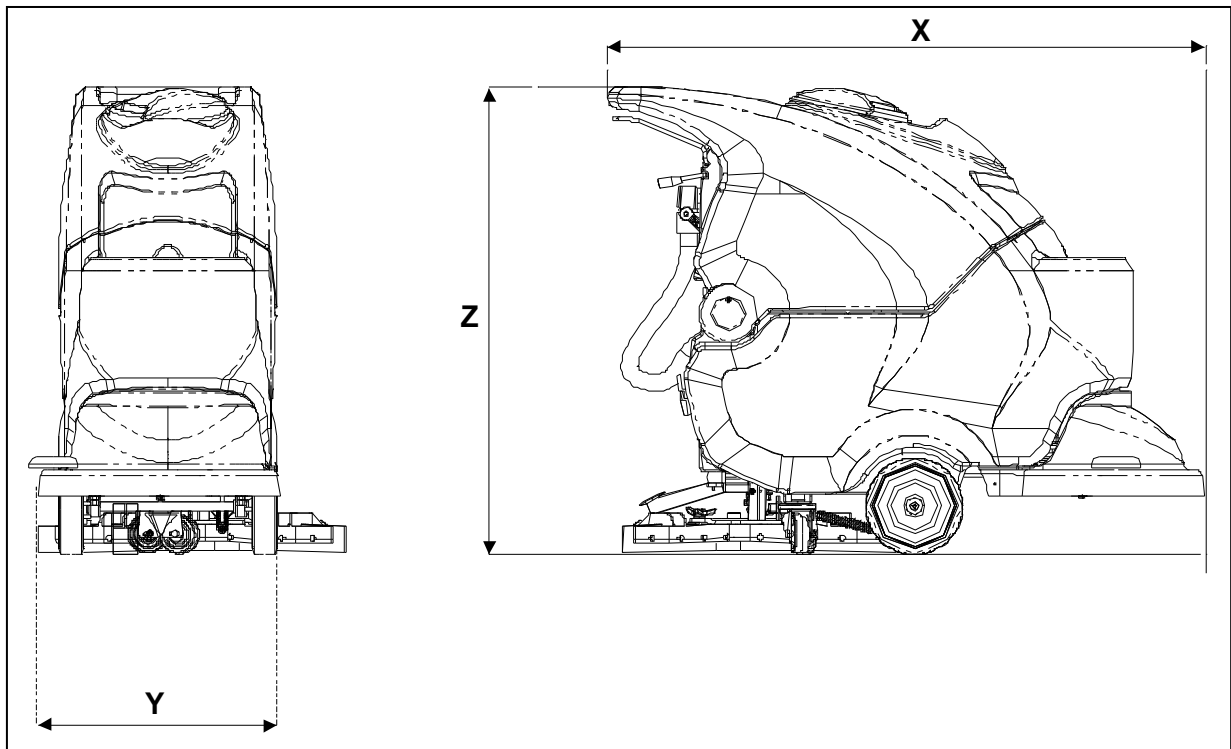

- X-Y-Z:** See table "TECHNICAL SPECIFICATIONS"
- X-Y-Z:** Sehen tab. "TECHNISCHE DATEN"
- X-Y-Z:** Voir tab. "DONNEES TECHNIQUES"
- X-Y-Z:** Vease tab. "CARACTERÍSTICAS TÉCNICAS"
- X-Y-Z:** Vedi tabella "CARATTERISTICHE TECNICHE"
- X-Y-Z:** Zie tabel "TECHNISCHE GEGEVENS"

**MACHINE SIZE - MASSE DER MASCHINE
DIMENSIONS DE LA MACHINE
DIMENSIONES DE LA MÁQUINA - DIMENSIONI MACCHINA
MACHINEAFMETINGEN**

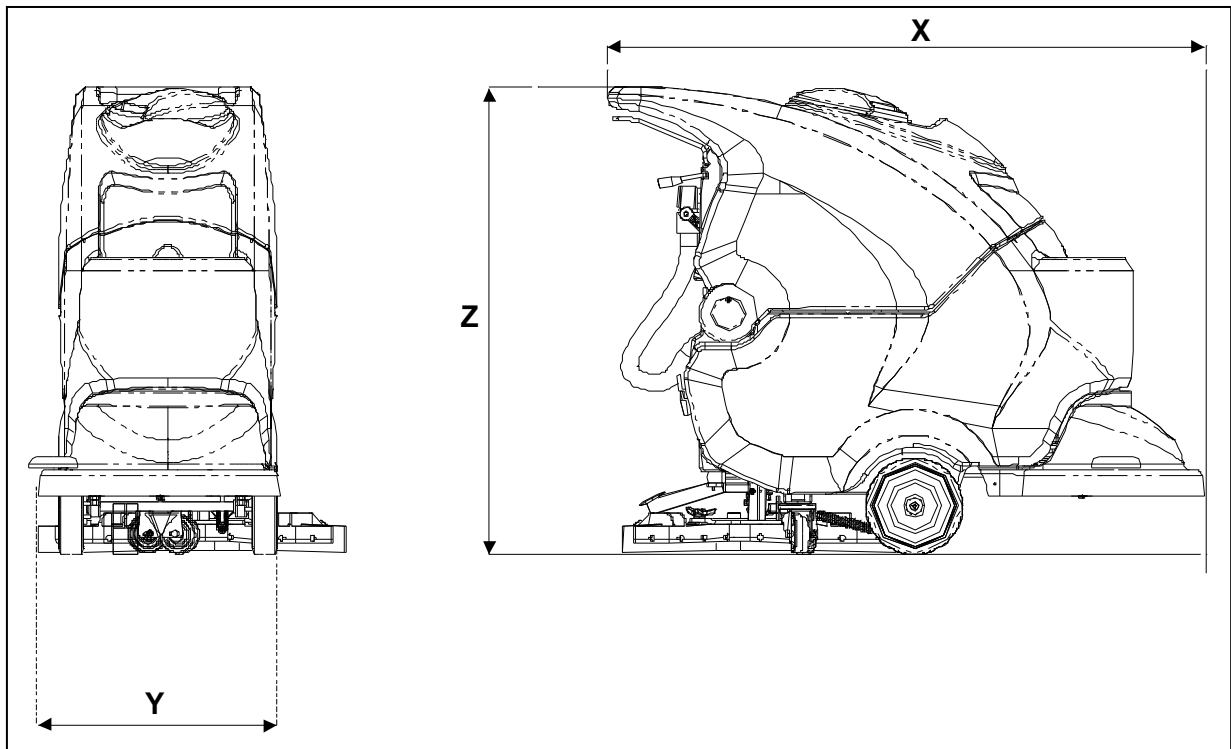

- X-Y-Z:** See table "TECHNICAL SPECIFICATIONS"
- X-Y-Z:** Sehen tab. "TECHNISCHE DATEN"
- X-Y-Z:** Voir tab. "DONNEES TECHNIQUES"
- X-Y-Z:** Vease tab. "CARACTERÍSTICAS TÉCNICAS"
- X-Y-Z:** Vedi tabella "CARATTERISTICHE TECNICHE"
- X-Y-Z:** Zie tabel "TECHNISCHE GEGEVENS"

Sound Pressure Schalldruck Pression Sonore Presion Sonora Pressione Sonora Geluidsdruk					
Sound Power Schalleistung Puissance Sonore Potencia Sonora Potenza Sonora Geluidsvermogen					
Vibration Level (arm) Schwivngungspegel (arm) Niveau de Vibrations (bras) Nivel de Vibraciones (brazo) Livello Vibrazioni (braccio) Trillingsniveau (arm)					
Vibration Level (hand-arm) Schwivngungspegel (hand-arm) Niveau de Vibrations (main-bras) Nivel de Vibraciones (mano-brazo) Livello Vibrazioni (mano-braccio) Trillingsniveau (hand-arm)					

Tab. A Data can be changed without notice.
 Diese Daten können ohne vorherige Benachrichtigung geändert werden.
 Données techniques pouvant changer sans préavis.
 Los datos pueden variar sin aviso previo.
 Dati soggetti a variazioni senza preavviso.
 Deze gegevens kunnen zonder voorafgaande kennisgeving veranderd worden.

**MACHINE SIZE - MASSE DER MASCHINE
 DIMENSIONS DE LA MACHINE
 DIMENSIONES DE LA MÁQUINA - DIMENSIONI MACCHINA
 MACHINEAFMETINGEN**

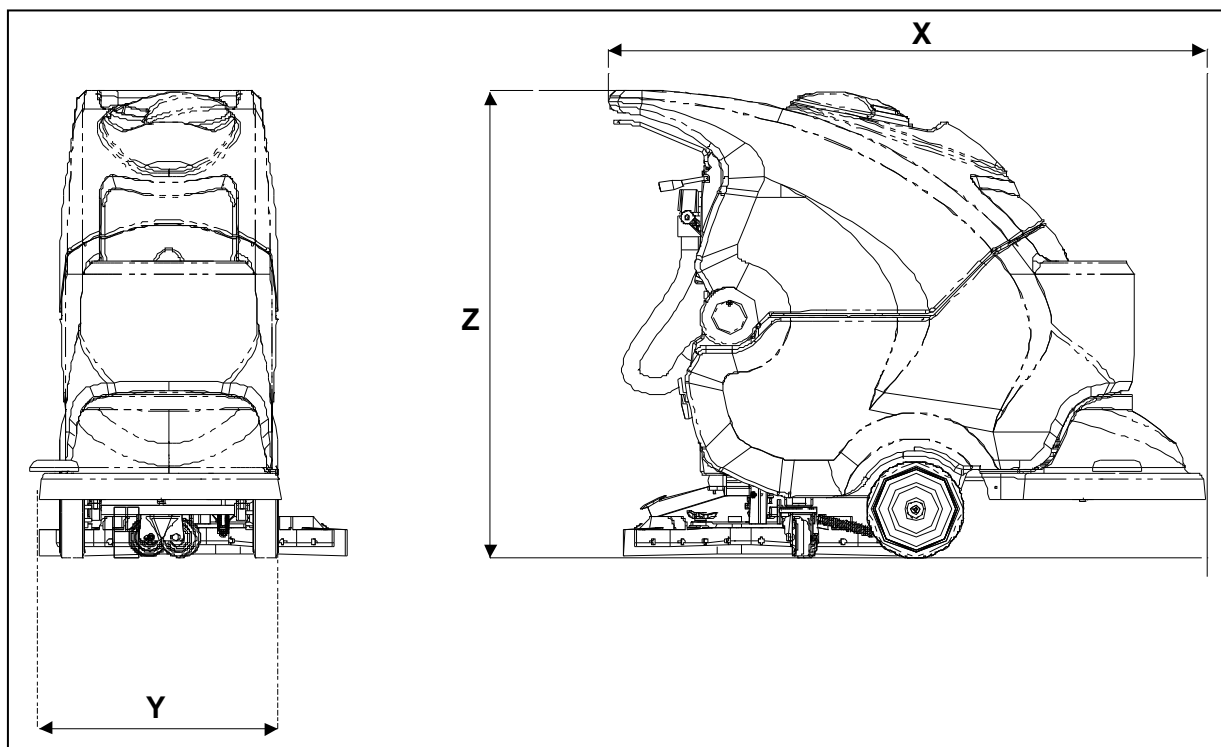

X-Y-Z: See table "TECHNICAL SPECIFICATIONS"
X-Y-Z: Sehen tab. "TECHNISCHE DATEN"
X-Y-Z: Voir tab. "DONNEES TECHNIQUES"
X-Y-Z: Vease tab. "CARACTERÍSTICAS TÉCNICAS"
X-Y-Z: Vedi tabella "CARATTERISTICHE TECNICHE"
X-Y-Z: Zie tabel "TECHNISCHE GEGEVENS"

ENGLISH

1. TABLE OF CONTENTS

1.	TABLE OF CONTENTS	2
2.	GENERAL INFORMATION	4
2.1	SCOPE OF THE MANUAL.....	4
2.2	IDENTIFICATION OF THE MACHINE.....	5
2.3	DOCUMENTATION ANNEXED TO THE MACHINE.....	5
3.	TECHNICAL INFORMATION	5
3.1	GENERAL DESCRIPTION.....	5
3.2	LEGEND.....	5
3.3	DANGER AREAS.....	6
3.4	ACCESSORIES.....	6
4.	INFORMATION ON SAFETY	6
4.1	SAFETY STANDARDS.....	6
5.	HANDLING AND INSTALLATION	8
5.1	LIFTING AND CARRYING THE PACKED MACHINE.....	8
5.2	CHECKING THE MACHINE ON DELIVERY.....	9
5.3	UNPACKING.....	9
5.4	ELECTRIC CONNECTIONS AND GROUNDING (MODELS WITH CABLE).....	9
5.5	FEEDING BATTERIES (MODELS WITH BATTERY).....	10
5.5.1	<i>Batteries: preparation</i>	10
5.5.2	<i>Batteries: installation and connection</i>	10
5.6	THE BATTERY-CHARGER (MODELS WITH BATTERY).....	11
5.6.1	<i>Choosing the battery-charger</i>	11
5.6.2	<i>Preparing the battery-charger</i>	11
5.7	LIFTING AND HANDLING THE MACHINE.....	11
6.	PRACTICAL GUIDE FOR THE USER	12
6.1	CONTROL DEVICES - DESCRIPTION.....	12
6.2	INSTALLING AND ADJUSTING THE SQUEEGEE.....	13
6.3	MOVEMENT OF THE MACHINE WHEN NOT OPERATING.....	13
6.4	FITTING AND CHANGING THE BRUSHES / DRIVE DISCS.....	13
6.5	DETERGENTS - USE.....	14
6.6	SETTING UP THE MACHINE.....	15
6.7	WORK.....	15
6.8	SOME USEFUL SUGGESTIONS FOR THE OPTIMAL USE OF THE MACHINE.....	16
6.8.1	<i>Pre-washing</i>	16
6.8.2	<i>Drying</i>	17
6.9	DRAINING OFF DIRTY WATER.....	17
6.10	DRAINING OFF CLEAN WATER.....	17
7.	PERIODS OF INACTIVITY	18
8.	MAINTENANCE AND BATTERY RECHARGING	18
8.1	RECHARGING PROCEDURES.....	18
9.	INSTRUCTIONS FOR MAINTENANCE	18
9.1	MAINTENANCE – GENERAL RULES.....	19
9.2	ROUTINE MAINTENANCE.....	19
9.2.1	<i>Suction air filter and floater: cleaning</i>	18
9.2.2	<i>Basket filter: cleaning</i>	19
9.2.3	<i>Detergent solution filter: cleaning</i>	19
9.2.4	<i>Squeegee blades: replacement</i>	19
9.2.5	<i>Fuses: replacement</i>	20
9.3	PERIODIC MAINTENANCE.....	20
9.3.1	<i>Daily maintenance</i>	20
9.3.2	<i>Weekly maintenance</i>	20
9.3.3	<i>Six-monthly maintenance</i>	20

10.	HOW TO ORDER SPARE PARTS	21
11.	TROUBLESHOOTING.....	22
11.1	HOW TO OVERCOME POSSIBLE FAILURES.....	22

2. GENERAL INFORMATION



Read this manual carefully before starting any operations on this machine¹.

2.1 Scope of the manual

This manual has been drawn up by the Manufacturer and is considered as an integral part of the machine.

It defines the purpose for which the machine has been manufactured and contains all information the operators² require.

Besides this manual, which contains the necessary information for the users, other publications have been issued, which contain the specific information for the technicians in charge of maintenance³.

The constant observance of the instructions guarantee the safety of man and machine, low running costs, quality results and a longer work life of the machine itself. The non-observance of the prescribed rules could injure men, damage the machine, spoil the washed floor and even the environment.

To find the single topics in a fast way, see the descriptive table of contents at the beginning of this manual.

The paragraphs that are not to be neglected are printed in bold letters and preceded by symbols illustrated and defined below.

! DANGER

Indicates that attention must be paid to avoid serious consequences that could cause the death of the personnel or possible damages to health.

⚠ WARNING

Indicates that attention must be paid to avoid serious consequences that could damage the machine, spoil the environment where the machine is used or cause economic losses.

i INFORMATION

Particularly important instructions.

In following a policy of constant development and update of the product, the Manufacturer could implement modifications without any previous notice.

Even though the machine you own is greatly different from the one(s) illustrated in this manual, safety and information thereof are guaranteed anyway.

¹ The definition "machine" substitutes the commercial name to which this manual refers.

² People authorised to use the machine without carrying out maintenance operations that require precise technical knowledge.

³ People having the experience, technical preparation and knowledge of the regulations and laws necessary to carry out the activity and capable to recognize and avoid possible dangers when handling, installing, using the machine and carrying out maintenance operations.

2.2 Identification of the machine

The number plate (fig. 1), which is attached at the rear of the machine, shows the following information:

- model code;
- machine model;
- power supply voltage;
- total rated power;
- serial number (registration number);
- year of manufacture;
- dry weight;
- maximum full load weight;
- steepest slope that can be overcome;
- bar code with serial number;
- manufacturer's identification.

2.3 Documentation annexed to the machine

- User's Manual;
- warranty certificate;
- adhesive slips for spare part orders;
- test sheet;
- CE Certificate of conformity.

3. TECHNICAL INFORMATION

3.1 General description

The machine is a sweeping scrubber, which can be used in civil and industrial environments for sweeping, washing and drying flat, horizontal, smooth or moderately rough floors, with even surfaces and free from obstacles. It is available either in the version with battery or with cable to meet with any requirements of autonomy and weight. The scrubber distributes on the floor an adequately dosed solution of water and detergent, and brushes it to remove dirt. Choosing with care the right cleaning detergent and brushes (or abrasive discs) in the wide range of accessories available, the machine can adapt itself to all kinds of combinations of floors and dirt.

With the liquid suction system incorporated in the machine, the floor can also be dried after washing. Drying is performed by means of the underpressure in the recovery tank generated by the suction motor. The floor cleaner, connected to the tank, collects the dirty water.

The machine is moved forward by:

MOD 50/55 B/C mechanical drive: the cleaner is provided with a special mechanical drive device, which uses the friction between the brush and the floor to generate a thrust forward (for further specifications, see par. 6.7).

MOD 50/55 BT electrical drive: the cleaner is provided with a special electromechanical drive device, which moves the machine forward.

3.2 Legend

The main components of the machine are the following (fig. 2):

- the detergent solution tank (fig. 2, ref. 7): used to contain and carry the mixture of clean water and detergent;
- the recovery tank (fig. 2, ref. 2): used to collect dirty water sucked up from the floor during washing;
- control panel (fig. 2, ref. 1);

- head unit (fig. 2, ref. 4): the main element is represented by the brushes (fig. 2, ref. 5), which distribute the detergent solution on the floor, removing dirt;
- squeegee unit (or floor wiper, fig. 2, ref. 6): used to wipe and dry the floor, sucking up the water spread on the floor;
- head lift pedal (fig. 2, ref. 3): allows you to raise the brush head during transport.

3.3 Danger areas

A **-Tank unit**: in presence of certain detergents, danger of irritation for the eyes, skin, mucous diaphragms, respiratory apparatus and asphyxia. Danger caused by dirt recovered from the environment (germs and chemical substances). Danger of crushing between the recovery tank and solution tank, when the recovery tank is replaced on the solution tank.

B **-Control panel**: danger of shortcircuits.

C **-Bottom of washing head**: danger caused by the brush rotation.

D **-Rear wheels**: danger of crushing between wheels and chassis.

E **-Battery compartment** (located within the solution tank): danger of short circuits between the battery poles and presence of hydrogen during battery charging.

3.4 Accessories

- **Bristle brushes**: used for washing delicate floors and for polishing;
- **Polipropilene brushes**: used for normal floor washing;
- **Tynex brushes**: used to remove accumulated stubborn dirt on resistant floors;
- **Drive discs**: allow the use of the following discs:
 - * yellow discs: used for washing and polishing marble and similar surfaces;
 - * green discs: used for washing of resistant floors;
 - * black discs: used for thorough washing of resistant floors with stubborn dirt;

4. INFORMATION ON SAFETY

4.1 Safety standards



Read the User's manual carefully before proceeding with start-up, use, maintenance, routine maintenance or any other operations on the machine.

WARNING

Stick to all the instructions contained in this Manual (especially those regarding danger and warning) and observe the safety plates attached on the machine. The Manufacturer declines all responsibility for injuries to persons or damage to things deriving from the non-observance of these instructions.

The machine must be used by trained personnel only, who have shown their skill and have been expressly authorized to use it.

Persons under eighteen cannot use the machine.

This machine must not be used for any other purpose than that for which it has been expressly manufactured. Assess the type of building in which it will be used (e.g. pharmaceutical and chemical companies, hospitals, etc.) and scrupulously respect the regulations and conditions in force.

Do not use the machine in places that are not adequately lighted, in environments with danger of explosions, on public roads, in the presence of dirt harmful to health or improper environments.

The suitable temperature for the use of the machine ranges between +4°C and +35°C; when the machine is not used, the temperature range is between +0°C e +50°C.

The humidity range for the machine under any conditions varies between 30% and 95%.

Never use or suck up inflammable or explosive liquids (e.g. petrol, fuel oil, etc.), inflammable gases, dry dust, acids and solvents (e.g. solvents for paints, acetone, etc.) even if diluted. Never suck up any burning or white-hot objects.

Do not use the machine on slopes or ramps higher than 2%; in the event of light slopes do not use it transversally, handle it with extreme care and do not reverse. When driving along ramps or heavier slopes take great care to avoid overturning or uncontrolled acceleration. Overcome ramps and/or steps exclusively with the brush head and squeegee lifted.

Never park the machine on slopes.

Never leave the machine in operation unattended. Leave the machine only after having switched off the motor, made sure that it cannot move accidentally and unplugged it from the mains.

When using the machine mind the presence of people particularly children in the environment where you are working.

Do not use the machine to carry persons/things or to tow things. Do not drag the machine.

Never lay things on the machine for any reason.

Do not obstruct the air vents and heat dispersion openings.

Do not remove, modify or elude the safety devices.

Various and unpleasant experiences have shown that people wear or carry various objects capable of causing serious accidents: before starting to work, remove trinkets, watches, neckties or other such things.

Always use individual safety protections: apron or protective suit/overalls, non-slip waterproof shoes, rubber gloves, protective goggles and caps, face mask to protect the respiratory system.

Do not put the hands in between moving organs.

Do not use detergents different from those provided for, and stick to the instructions indicated on the respective safety sheets. Keep detergents in a safe place, inaccessible to children, and in case they come in contact with the eyes, wash them immediately with plenty of water or, if swallowed, call for a doctor immediately.

Make sure that the plugs for the power supply of the models with cable or of the battery-chargers are properly grounded and protected by magnetothermal switches and differentials.

Make sure that the electric characteristics of the machine (voltage, frequency, absorbed power) indicated on the identification plate (fig. 1), are compliant with those of the power distribution plant. The machine with cable is equipped with three lead wires and a three-contact ground plug for the use of a proper grounding plug. The yellow and green wire of the cable is the earth wire: never connect this wire to other wires that are not the plug ground tap.

It is fundamental to observe the battery Manufacturer's instructions and stick to the Legislator's provisions. Keep batteries always dry and clean to avoid surface leakage currents. Keep batteries safe from impurities, for instance metal dust.

Do not lay tools on batteries: danger of short circuits and explosions.

Mind the use of battery acid: stick to the relative safety instructions.

When using the machine model with cable mind that you do not crush or tear the power supply cable. Check this cable periodically to control if it is damaged; if this is so, the machine cannot be used.

In presence of particularly high magnetic fields assess the possible effects on the control electronics.

Never wash the machine with jets of water.

The recycled fluids contain detergents, disinfectants, water, organic and inorganic stuff recycled during the work stages: they must be disposed of in compliance with the laws in force.

In case of breakdown and/or bad operation of the machine, switch it off immediately (unplugging it from the mains) and do not tamper with it. Contact a technical assistance centre of the Manufacturer's.

All maintenance operations must be performed in adequately lighted environments and only after having disconnected the machine from the power supply (in models with cable by unplugging the machine from the socket, while in models with battery by detaching the battery connector).

Have any electrical work and all maintenance and repair operations (particularly those not explicitly described in this manual) carried out a specialised and trained technical staff only.

In case of replacement of the power supply cable, plug or terminals, perform the repair by properly fixing the electric connections and the cable blocking strap that is located in the control panel, to guarantee the resistance of the cable. Then reassemble the panel with care to ensure the protection of the machine user.

Only the use of original accessories and spare parts supplied by the Manufacturer is permitted, as only these offer the certainty that the machine will operate safely and without any inconveniences. Do not use parts removed from other machines or other kits as spares.

This machine has been designed and manufactured for a service endurance of ten years starting from the date of manufacture, which can be seen on the identification plate (see fig. 1). After this time, whether the machine has been used or not, disposal must be considered according to the laws in force in the place of use:

- the machine must be disconnected from the mains, emptied of all liquids and cleaned;
- this product is classified as RAEE type special waste and is covered by the requisites of the new environmental protection regulations (2002/96/CE RAEE). It must be disposed of separately from ordinary waste in compliance with current legislation and standards.



Special waste. Do not dispose of with ordinary waste.

Alternatively, the machine can be sent to the Manufacturer for a thorough overhaul.

If the machine is not used anymore, it is recommended that batteries are removed and deposited at an authorized collecting centre.

Moreover, it is recommended that you make harmless those parts of the machine that could be dangerous especially to children, who could use the machine for their games.

5. HANDLING AND INSTALLATION

5.1 Lifting and carrying the packed machine

WARNING

In all lifting operations make sure that the packed machine has been tightly anchored to the pallet, in order to avoid any overturning or accidental falls. Loading and/or unloading from the motor vehicles must be performed in an

adequately lighted environment.

The machine, which is packed on a wooden pallet by the Manufacturer, must be loaded by means of proper handling machines (refer to the EEC provision 89/392/CEE and following amendments), onto the carrier and, once it has arrived at the appointed destination, unloaded by similar means.

The squeegees are packed in cardboard boxes without a pallet.

The packed machine body must be lifted only with a fork lift truck. Handle with care to avoid bumps or overturnings.

5.2 Checking the machine on delivery

On delivery check with attention that the package and the machine are not damaged. In the event that the machine has suffered any damages, report so to the carrier; before accepting the goods, reserve by written the right to present a claim for the refund of the damages.

5.3 Unpacking

WARNING

On unpacking the machine, the operator must be provided with the necessary accessories (e.g. gloves, protective goggles etc.) to limit possible hazards of accidents.

Unpack the machine in the following way:

- cut and remove the plastic straps with scissors or nippers;
- remove the cardbox;
- remove the envelopes inside the battery compartment (within the solution tank) and check its contents:
 - envelope 1: - test sheet;
 - warranty coupon;
 - user's and maintenance manual;
 - list of spare parts;
 - cards with serial numbers to order spare parts;
 - envelope 2: - 1 battery bridge with clips (for battery models only);
 - 1 pair of tweezers for fuses (for battery models only);
 - 1 connector for the battery-charger (for battery models only);
- depending on the model, remove the metal brackets or cut the plastic straps, which fix the machine chassis to the pallet;
- let the machine slide down the pallet on an inclined plane, by pushing it into reverse;
- unwrap the brushes (fig. 3, ref. 1) and the squeegee (fig. 3, ref. 2) from their packing;
- clean the outside of the machine observing the safety rules;
- after unpacking the machine, you can install the batteries (models with battery) or perform the electric connections (models with cable): see respective paragraphs.

If necessary, preserve the wrapping material as it could be used again to protect the machine in the event of a move or if the machine should be sent to a service centre for repair.

Otherwise, the material must be disposed of in compliance with the laws in force.

5.4 Electric connections and grounding (models with cable)

On the identification plate (fig. 1) the electric characteristics of the machine are written: make sure that the frequency and line tension are the same of those of the environment where you are going to work.

As far as voltage is concerned, the models showing a voltage of 230 V on the plate can be used for voltages ranging from 220 to 240 V. The same is true for the models showing a voltage value of 115 V, which can be used for voltages ranging from 110 to 120 V. The frequency indicated on the plate must always correspond to that of the mains.

WARNING

Check that the electric plant is provided with a suitable ground line and that the plugs (and any reducers being used) guarantee the continuity of the ground lead wires.

! DANGER

The non-observance of the prescribed rules can cause serious damages to persons and things and the invalidity of the guarantee.

5.5 Feeding batteries (models with battery)

Two different batteries can be fitted on this machine:

- **Tubular leak-proof batteries:** these batteries require the periodical check of the electrolyte level. When it is necessary, top up with distilled water alone until the plates are covered; do not overfill (max. 5 mm. above the plates).
- **Gel batteries:** this kind of batteries requires no maintenance.

The technical specifications must correspond to those indicated in the paragraph concerning the machine technical data: actually, the use of heavier storage batteries can cause serious problems to the machine controllability and overheat the brush motor, whereas storage batteries with a lower capacity require recharges more frequently. They must be kept charged, dry and clean, with their connections tight.

5.5.1 Batteries: preparation

! DANGER

On installing or performing any kind of maintenance on the batteries wear the necessary accessories (e.g. protective gloves, goggles, overalls, etc.) to limit the hazards of accidents, keep away from possible free flames, do not short-circuit the battery poles, cause sparks or smoke.

The batteries are normally supplied filled with acid and ready-for-use.

If batteries without acid are to be used, before mounting them on the machine, it is necessary to make them active as follows:

- after taking off the battery plugs, fill up all elements with a solution of specific sulphuric acid, until the cells are thoroughly covered (fill each element at least twice);
- let them rest for about 4-5 hours, to give time to air bubbles to come up to the surface and the plates to absorb the electrolyte;
- check that the electrolyte level is still above the plates, otherwise top up with the solution of sulphuric acid;
- reclose the plugs;
- install the storage batteries on the machine (following the procedure described below).

It is now necessary to perform a first recharging before having the machine start; to do so stick to the instructions written in the respective paragraph.

5.5.2 Batteries: installation and connection

! DANGER

Check that all switches on the control panel are at the position “0” (off). Mind you connect only the clips marked with the symbol “+” to the positive poles. Do not check the battery charge by creating sparkles. Stick scrupulously to the instructions described below, as any short circuits of the batteries may cause them to explode.

- 1) Make sure that the two tanks are empty (empty them, if necessary: see respective paragraph);

- 2) disconnect the Anderson connector (fig. 5, ref. 2) of the battery wiring from the corresponding Anderson connector (fig. 5, ref. 1) of the main wiring;
- 3) release the recovery tank (fig. 2, ref. 2) from the solution tank (fig. 2, ref. 7) by pulling the release hook (fig. 4, ref. 1) on the rear of the machine;
- 4) lift the recovery tank, by making it turn backwards around about 90°: in this way you have access to the battery compartment (embedded in the solution tank) from the upper side;
- 5) insert the batteries in the compartment, orienting them as shown in the drawing printed on the solution tank in the compartment.

WARNING

Install the storage batteries on the machine using suitable means according to their weight.

Positive and negative poles have different diameters.

- 6) Referring to the arrangement of cables in the aforesaid drawing, connect the clips of the battery wiring and the bridge to the poles of the storage batteries. After orienting the cables as shown in the drawing, tighten the clips at the poles and cover them with vaseline;
- 7) insert back the tank unit in its work position and hook it to the solution tank;
- 8) after having checked that all switches on the control panel are at the position "0" (off), connect the battery wiring connector (fig. 5, ref. 2) to the machine wiring connector (fig. 5, ref. 1);
- 9) use the machine in compliance with the instructions written below.

5.6 The battery-charger (models with battery)

WARNING

Never let the batteries run down excessively, as they could become damaged irreparably.

5.6.1 *Choosing the battery-charger*

Check that the battery-charger is compatible with the batteries to be charged:

- **tubular lead batteries:** an automatic battery-charger 24V - 20A is suggested. Anyway, refer to the Manufacturer and read the relative manual to confirm your choice;
- **gel batteries:** use a battery-charger specifically intended for this type of storage batteries.

5.6.2 *Preparing the battery-charger*

If you wish to use a battery-charger not supplied with the machine, it is necessary to mount on it the connector delivered with the machine (see paragraph "Unpacking" of this manual).

To install the connector proceed as follows:

- remove about 13 mm of sheath from the black and red cables of the battery-charger;
- insert the cables in the connector pins and push strongly with suitable pliers;
- insert the cables in the connector respecting the polarity (red cable +, black cable -).

5.7 Lifting and handling the machine

WARNING

All stages must be performed in an adequately lighted environment adopting all necessary safety measures.

Always wear individual protections for the user's safety.

The loading of the machine onto a vehicle must be done as follows:

- empty the recovery tank and the solution tank;
- remove the squeegee and the brushes (or drive discs);
- remove the batteries (in models with battery);
- put the machine on the pallet, by anchoring it with plastic straps or the proper metal brackets;
- lift the pallet by means of a fork lift truck and load it on the vehicle;
- anchor the machine to the vehicle with ropes connected to the pallet and to the chassis of the machine.

6. PRACTICAL GUIDE FOR THE USER

6.1 Control devices - Description

With reference to fig. 6 the machine has the following controls and leds:

- **Power supply led** (fig. 6, ref. 1 – in models with cable only): it is green and indicates that the power supply cable of the machine is connected to mains.
- **Battery charge check led** (fig.6, ref. 1 – in models with battery only): consisting of 3 yellow leds, it indicates the battery charge level. It can be:
 - a) **3 leds on**: batteries charged from 100% to 50%;
 - b) **2 leds on**: batteries charged from 50% to 18%;
 - c) **1 led on**: batteries almost flat;
 - d) **1 led blinking**: batteries completely flat; after a few seconds the brushes are locked and the brush switch light also comes on.
- **Main switch - emergency button with key (fig. 6, ref. 14): turns the power supply to all machine functions on and off. It acts as a safety device.** To start the machine up, turn the key clockwise. To stop the machine, press the button.
- **Versions with mechanical drive: Brush switch with LED** (fig. 6, ref. 3): enables ("1") or disables ("0") the function "Brush".
- **Versions with electric drive: Brush button with LED** (fig. 6, ref. 3): enables (LED on) or disables (LED off) the "Brush" function.
- **Versions with mechanical drive: Suction switch with LED** (fig. 6, ref. 2): switches on ("1") or off ("0") the suction motor, which allows to dry the floor just washed. The led is on when the suction unit is fed.
- **Versions with electric drive: Suction button with LED** (fig. 6, ref. 2): turns the suction motor responsible for drying the floor on (LED on) or off (LED off). The light is on when there is power to the suction motor.
- **Cock control lever** (fig. 6, ref. 6): allows to adjust continuously the flow of solution sent to the brushes. Pull up to increase the liquid outflow.
- **Drive control lever** (fig. 6, ref. 7): the drive control lever permits forward movement of the machine and rotation of the brushes.
- **Squeegee lifting lever** (fig. 6, ref. 8): it allows to raise (when lifted) or lower (when pushed down) the squeegee.
- **Direction adjustment knob** (fig. 6, ref. 10): turn to correct any deviation of the machine and keep it moving in a straight line.
- **Head lower/lift pedal** (fig. 6, ref. 9): located on the left-hand side of the machine, when pressed it lowers/raises the brush head.
- **Solution tank level indicator** (fig. 6, ref. 5): the led comes on to indicate insufficient water in the solution tank.
- **Recovery tank level indicator** (fig. 6, ref. 4): when the recovery tank is full the led comes on and after a few seconds the suction motor locks out.

- **Display.** Displays any alarms active. During normal operation, it displays the hour counter (giving the actual number of hours the machine has been operating).

6.2 Installing and adjusting the squeegee

The floor wiper, also called squeegee (fig. 2, ref. 6), is the first responsible for drying.

To install the squeegee on the machine proceed as follows:

- 1) check that the squeegee supporting plate (fig. 7, ref. 2) is raised, otherwise lift it by acting on the proper lever (fig. 7, ref. 5);
- 2) firmly push down the sleeve of the suction tube (fig. 7, ref. 4) into the squeegee;
- 3) slacken the two knobs (fig. 7, ref. 3) placed in the centre of the squeegee;
- 4) insert the two threaded dowels in the slots of the support (fig. 7, ref. 2);
- 5) fix the squeegee by tightening the knobs (fig. 7, ref. 3).

The blades of the squeegee are used to scrub from the floor the film of water and detergent thus allowing a perfect drying. As long as time goes by the continuous scraping rounds off and splits the sharp edge in contact with the floor, thus reducing the drying efficacy and therefore requiring the replacement of the blades. Therefore, often check their state of wear and tear.

To obtain a perfect drying action it is necessary to adjust the squeegee in such a way that when it is in operation, the rear blade lip is bent about 45 degrees with respect to the floor at all points. The angle of the blades during work can be adjusted by adjusting the height of the two wheels positioned behind the squeegee (fig. 7, ref. 1).

6.3 Movement of the machine when not operating

To move the machine, perform the following operations:

- 1) raise the squeegee;
- 2) push the head movement pedal down and then to the right (fig. 6, ref. 9) to raise the head;
- 3) move as follows:
 - **versions with mechanical drive:** push or pull;
 - **versions with electric drive:** for forward movement, press the button (fig. 6, ref. 13), (LED fig.6 ref.14 on) and then operate the drive lever (fig. 6, ref.7). For reverse movement, press the button again (fig. 6, ref. 13), (LED fig.6 ref.12 on) and then operate the drive lever (fig. 6, ref. 7).
Speed can be varied by the potentiometer knob (fig. 6, ref. 11).
- 4) once you have reached your destination, lower the head by pressing the release pedal down to the left (fig. 6, ref. 9) and then release it.

WARNING

Do not leave the machine unattended or parked with the head lifted or with the key inserted in the emergency button.

6.4 Fitting and changing the brushes / drive discs

CAUTION

Do not work without the brushes or drive disc perfectly fitted.

Fitting the brush: rest the brush/brushes on the floor in front of the machine and centre it with the casing. Lower the head and operate the brush/drive control lever (fig. 6, ref. 7) for a few moments: in this way, the brush/brushes automatically engages on the flange hub. If this operation is not successful, press the handgrip again and repeat centring and operation of the brush/drive control lever.

Use of **abrasive discs:** fit the abrasive disc on the drive disc and perform the operations described for fitting the brush on the cleaner.

Removing the brush (or drive disc). Follow the instructions below:

raise the machine head by pushing the head lift pedal down and then to the right (fig. 6, ref. 9) and repeatedly operate the brush/drive lever in short spurts. After a few times, the

brush/brushes (or drive disc) will be released and fall to the ground.

6.5 Detergents - Use

WARNING

Always dilute detergents according to the supplier's instructions. Do not use sodium hypochlorite (bleaching solution) or other oxidizers, especially if in high concentrations, and do not use solvents or hydrocarbons. The temperatures for water and detergent must not exceed the maximum temperatures indicated in the technical data and must be free from sand and/or other impurities.

The machine has been designed to be used with non-foaming and biodegradable detergents specific for sweeping scrubbers.

Contact the Manufacturer to have a complete and updated list of the available detergents and chemical products; you will receive all papers together with the Manual "Complete cleaning system".

Use only products suitable for floors and for removing dirt.

Follow the safety rules concerning the use of detergents indicated in the paragraph "Safety regulations".

6.6 Setting up the machine

WARNING

Before starting to work wear an apron, cap, non-slip waterproof shoes, a mask to protect the respiratory system, gloves and any other form of protection indicated by the supplier of the detergent or necessary in the environment you are going to work in.

Perform the following operations before beginning work:

- ***Battery models***: check the battery charge level (recharge if necessary);
- lower the head by means of the pedal (fig. 6, ref. 9);
- ensure that the recovery tank (fig. 2, ref. 2) is empty; if not, empty it;
- check that the cock control lever (fig. 6, ref. 6) is in the “CLOSED” position;
- via the front opening provided, fill the solution tank (fig. 2, ref. 7) with clean water and non-foaming detergent in an appropriate concentration: leave at least 5 cm difference in level between the surface of the liquid and the tank inlet;
- fit suitable brushes or drive discs for the floor and the work to be performed (see paragraph 6.4);
- check that the squeegee (fig. 2, ref. 6) is well secured and connected to the suction pipe (fig. 7, ref. 4); ensure that the rear blade is not worn.

i INFORMATION

If you use the machine for the first time, it is advisable that you train with it for a short time on a wide surface without any obstacles, to acquire the necessary familiarity.

Always empty the recovery tank before refilling the solution tank.

For an effective cleaning and long life of the equipment, it is necessary to follow some simple rules:

- prepare the work area, keeping away the possible obstacles;
- begin to work starting from the farthest spot, in order to avoid trampling on the area just-cleaned;
- choose paths that are as much straight as possible;
- on wide floors divide the paths into rectangular and parallel areas.

At the end quickly mop the area, if necessary, to clean spots that are inaccessible to the scrubber.

6.7 Work

After setting up the machine, proceed as follows:

- connect the machine to the power supply:
 - ***models with cable***: plug the machine;
 - ***models with battery***: connect the ANDERSON connectors with each other (fig. 5, ref. 1 and ref. 2);
- move the cock lever (fig. 6, ref. 6) to the position of minimum flow of solution: the detergent solution begins to reach the brush;
- lower the squeegee by means of the proper lever (fig. 6, ref. 8);
- ***Versions with mechanical drive***: press “1” on the brush switch (fig. 6, ref. 3) to enable the function “Brush”;
- ***Versions with electric drive***: press the brush button (fig. 6, ref. 3)
- ***Versions with mechanical drive***: press “1” on the suction unit switch (fig. 6, ref. 2) to start the suction motor;
- ***Versions with electric drive***: press the suction button (fig. 6, ref. 2) to turn the suction motor on;
- press brush/drive control lever (fig. 6, ref. 7);
- ***Versions with mechanical drive***: when the brush switch is in position “1” and the drive lever is pulled, the motor will come on, thus rotating the brush and moving the

machine forward. The special mechanical drive device uses the friction between brush and floor to generate a thrust forward; when the mechanical drive lever is released, the brush motor will therefore switch off and the machine will consequently stop.

If necessary, correct any deviation of the machine and keep it moving in a straight line via the direction adjustment knob (fig. 6, ref. 10): if the machine tends to veer to the right, rotate the knob clockwise and vice versa.

- **Versions with electrical drive**: to move forwards or backwards, see paragraph 6.3.

In both versions:

- periodically check that the detergent solution reaches the brushes and refill when finished; when water in the solution tank is no longer sufficient, the level indicator will come on (fig. 6, ref. 5): stop and fill the tank;
- during work check the cleaning quality and adjust the solution flow sent to the brushes by raising or lowering the lever (fig. 6, ref. 6) as required.

WARNING

Whenever you fill up the solution tank, always empty the recovery tank. Do not leave the machine stationary with the suction motor on and the solution cock turned on.

- If the recovery tank is full, the level indicator will come on (fig. 6, ref. 4) and after a few seconds the suction motor will lock out: stop and empty the tank; to re-start the suction motor, switch the suction switch off and then on again (fig. 6, ref. 2).
- **Models with battery**: if the warning led (fig. 6, ref. 1) starts flashing, it means that the storage batteries are getting flat. After a few seconds the brushes lock to prevent excessive unload. Load them.

At the end of work:

- move the cock lever (fig. 6, ref. 6) to the position "CLOSED";
- release the brush/drive lever (fig. 6, ref. 7) placed beneath the handle: the brush/drive motor switches off and the machine stops;
- press "0" on the brush switch (fig. 6, ref. 3) to disable the function "Brush";
- raising the lever (fig. 6, ref. 8), lift the scrubber from the floor to prevent the drying blades from warping due to the continuous pressure;
- let the suction motor run for at least 2 minutes to make sure that it is completely dry; then press "0" on the suction unit switch (fig. 6, ref. 2) to switch off the suction motor;
- remove the brushes (or drive discs) to prevent them from warping permanently;
- depending on the model, unplug the machine or disconnect the ANDERSON connectors (fig. 5, ref. 1 and ref. 2);
- empty and clean the recovery tank.

WARNING

Both lead-acid batteries (set by default) and gel batteries can be installed. If gel batteries are installed, the dealer must operate the switch on the control panel electronic board.

6.8 Some useful suggestions for the optimal use of the machine

If the floor presents a particularly resistant type of dirt, it is possible to make the machine wash and dry it in separate stages.

6.8.1 Pre-washing

- Open the water cock;
- set the brush switch to position "1";
- lower the head;
- operate the drive lever to rotate the brushes;
- ensure that the suction device is off and that the squeegee is raised;

- begin washing.

The flow of water must be dosed in proportion to the desired advance speed: the slower the machine goes, less water comes down.

Insist on washing the dirtiest spots: in this way the detergent has the time to perform its chemical action for the detachment and suspension of dirt, and the brushes to develop an effective mechanical action.

6.8.2 *Drying*

Lower the squeegee and with the suction unit operating pass again on the same area you have previously washed. In this way you obtain a result that is similar to a thorough washing and the following operations of ordinary maintenance will certainly take less time. To wash and dry at the same time, operate the brush, water, squeegee and suction motor simultaneously.

6.9 Draining off dirty water

! DANGER

Use the individual protection devices suitable for the operation to be performed. Perform the draining operations with the machine disconnected from the power supply.

The drain hose of the recovery tank is located at the rear left side of the machine.

To empty the above-mentioned tank:

- take the machine next to a drain;
- detach the drain hose (fig. 8, ref. 2) from its seat, holding it in correspondence with the fixing spring (fig. 8, ref. 3) and pull it horizontally;
- keeping the hose end as much high as possible, take off the drain cock (fig. 8, ref. 4) by unscrewing it;
- lower the hose end gradually, checking the intensity of the jet of water with reference to its height from the ground;
- check the amount of residual dirt in the recovery tank and wash it inside, if necessary. To facilitate the cleaning and total drain, it is better to unhook it from the solution tank and lift it;
- when the dirty water has been totally drained, lower the recovery tank (if it has been previously lifted) and hook it again to the solution tank;
- close the drain hose (fig. 8, ref. 2) with the cock (fig. 8, ref. 4) screw-tightening it; check that it is perfectly closed and refit the hose in its housing.

! WARNING

While washing the recovery tank never remove the suction filter (fig. 10, ref. 2) from its seat and never direct the jet of water towards the filter itself.

Now it is possible to proceed with a new washing and drying action.

6.10 Draining off clean water

! DANGER

Use the individual protection devices suitable for the operation to be performed. Perform the draining off operations with the machine disconnected from the power supply.

To empty the tank:

- take the machine next to a drain;
- take off the drain cock (fig. 9, ref. 1)
- when the contents have been totally drained from the solution tank, close the cap (fig. 9, ref. 1); check that it is perfectly closed.

i INFORMATION

The water and detergent solution can also be used to wash the recovery tank.

7. PERIODS OF INACTIVITY

If the machine is to remain unused for a long time, the squeegee and brushes (or drive discs) must be dismantled, washed and kept in a dry place (preferably packed in a plastic envelope or sheet), sheltered from dust. Park the machine with the small carriage in the raised position.

Furthermore, make sure that the tanks are completely empty and perfectly clean.

Disconnect the machine from the power supply (depending on the model: unplug the machine from the mains or disconnect the ANDERSON connector from the battery wiring).

Models with battery: recharge the batteries completely before putting them in the storehouse. During long periods of inactivity recharge the batteries (once every two months at least) to preserve the storage batteries constantly at the maximum charge.

! WARNING

If the batteries are not recharged periodically, they may become damaged irreparably.

8. MAINTENANCE AND BATTERY RECHARGING

! DANGER

Do not check the battery charge by producing sparks.

The batteries give off inflammable vapours: put out any fire or embers before checking and filling up the batteries.

Perform the operations described below in airy environments.

To avoid permanent damages to the batteries, never let them get flat completely. Remember that when the proper red led (fig. 6, ref. 1) flashes on the control panel, it is necessary to recharge the batteries.

8.1 Recharging procedures

- Disconnect the battery wiring connector (fig. 5, ref. 2) from the main wiring connector (fig. 5, ref. 1);
- connect the battery-charger connector to the battery wiring connector;

! WARNING

Do NOT connect the battery-charger to the machine main wiring connector.
In the case of gel batteries, use only specific gel battery chargers.

- recharge following the instructions written in the manual to the battery-charger;
- at the end of the recharging time disconnect the connectors;
- reconnect the battery wiring connector to the machine connector.

9. INSTRUCTIONS FOR MAINTENANCE

! DANGER

Before carrying out any maintenance operations, unplug the machine from the mains (models with cable) or disconnect the machine connector from the battery connector.

All maintenance operations on the electric system and those not explicitly

described in this manual must only be performed by trained technical staff in compliance with the safety regulations in force and recommendations stated in the maintenance manual.

9.1 Maintenance – General rules

A regular maintenance performed according to the Manufacturer's instructions guarantees a better performance and endurance of the machine.

When cleaning the machine always observe the following instructions:

- avoid using water cleaners, which could let water go inside the electric or the motor compartments with a consequent damage or hazard of short circuits;
- do not use steam in order not to warp the plastic parts;
- do not use solvents or hydrocarbons, which could damage the hoods or the rubber parts.

9.2 Routine maintenance

9.2.1 Suction air filter and floater: cleaning

- Unscrew and take off the tank cap (fig. 10, ref. 1) from the recovery tank (fig. 10, ref. 4);
- make sure that the recovery tank (fig. 10, ref. 4) is empty;
- clean the floater (fig. 10, ref. 5) on the rear wall of the recovery tank ensuring that you do not aim the water jet directly at the floater;
- take out the air filter (fig. 10, ref. 2) of the suction unit from the float support (fig. 10, ref. 3), which is located on the upper inner side of the recovery tank;
- clean the filter with current water or with the detergent used in the machine;
- put the filter back in the support only after having it dried well; make sure that the filter has been replaced in its seat correctly;
- screw again the cap on the recovery tank.

9.2.2 Basket filter: cleaning

- Take the basket filter out of the water inlet at the front of the machine;
- clean the filter under running water or with the detergent used in the machine;
- refit the filter in the support, ensuring that you have repositioned it correctly.

9.2.3 Detergent solution filter: cleaning

- Unscrew the screw located below the bottom tank (fig. 11, ref. 1);
- unscrew the detergent solution filter (fig. 11, ref. 2);
- clean the filter under running water or with the detergent used in the machine;
- refit the filter in the support, ensuring that you have repositioned it correctly, and retighten the screw.

9.2.4 Squeegee blades: replacement

The blades of the squeegee are used to scrub from the floor the film of water and detergent thus allowing a perfect drying. As long as time goes by the continuous scraping rounds off and splits the sharp edge in contact with the floor, thus reducing the drying efficacy and therefore requiring the replacement of the blades. Therefore, often check their state of wear and tear.

Exchanging or replacing the blades:

- lower the squeegee by using the proper lever (fig. 6, ref. 8);
- take off the squeegee (fig. 2, ref. 6) from its supporting plate (fig. 7, ref. 2) by unscrewing completely the two knobs (fig. 7, ref. 3);
- slide out the sleeve of the suction tube (fig. 7, ref. 4) from the squeegee.
- unhook the hook clamp (fig. 12, ref. 3 or 6);
- slide out the two blade clamps (fig. 12, ref. 2 or 7) by first pushing them outwards with respect to the squeegee unit (fig. 12, ref. 1) and then taking them out;

- remove the blade (fig. 12, ref. 4 or 5);
- fit in the same blade inverting the edge in contact with the floor until all the four edges are worn, or else fit in a new blade embedding it in the screws of the squeegee unit (fig. 12, ref. 1);
- put the two blade clamps (fig. 12, ref. 2 or 7) back, centering the largest part of the slots on the fixing screws of the squeegee unit (fig. 12, ref. 1) and then pushing the blade clamps towards the inside of the squeegee itself;
- hook the clamp (fig. 12, ref. 3 or 6) again.

Insert the squeegee back on its support following the instructions reported in §6.2.

9.2.5 Fuses: replacement (models with battery)

The fuse protecting the brush motor and the fuse protecting the suction motor are located in the fuse carrier (fig. 13, ref. 1) fixed to the recovery tank above the machine battery compartment. To replace them:

- ensure that the recovery tank is empty; if not, empty it;
- raise the recovery tank;
- raise the fuse block cover and remove the fuse by unscrewing the fixing screws;
- fit a new fuse and close the fuse block cover;
- lower the recovery tank.

Fuse table: for the complete fuse table, consult the spare parts catalogue.

WARNING

Never fit a fuse with a higher Amp value than the intended one.

If a fuse keeps burning, it is necessary to identify and repair the damages present in the wiring, boards (if fitted) or motors: have the machine checked by trained technical staff.

9.3 Periodic maintenance

9.3.1 Daily maintenance

Every day at the end of work perform the following operations:

- disconnected the machine from the power supply;
- empty the recovery tank and clean it, if necessary;
- clean the squeegee blades, checking that they are not excessively worn; replace them, if necessary;
- make sure that the squeegee suction hole is not clogged, freeing it from any encrusted dirt;
- **Models with battery:** recharge the batteries according to the procedure described above.

9.3.2 Weekly maintenance

- Clean the recovery tank floater and check that it works correctly;
- clean the suction air filter and check that it is not damaged (replace it, if necessary);
- clean the solution filter placed at the front opening of the solution tank (fig. 2, ref. 7) and check that it is not damaged (replace it, if necessary);
- clean the suction tube;
- clean the recovery tank and the solution tank;
- ***Models with battery:*** check the level of the electrolyte in the batteries and top up with distilled water, if necessary.

9.3.3 Six-monthly maintenance

Have the electric system checked by qualified staff.

10. HOW TO ORDER SPARE PARTS

For a correct identification by our After-sales Service Office of the spare part(s) you need and, therefore, to help us serving you better, please fill in your orders with the following data:

- machine model;
- machine serial number on the identification plate (see fig. 1);
- chart of the list of spare parts in which the item and its reference number are found;
- code of the item to be found in the list of spare parts;
- amount ordered.

If you ask for a replacement under warranty terms, the order must be completed with a brief description of the fault.

11. TROUBLESHOOTING

11.1 How to overcome possible failures

[B]= machines with battery

[C]= machines with cable

[BT]= battery machine with electrical drive

Possible failures affecting the whole machine

FAILURES	CAUSES	REMEDIES
The machine does not work	• [B]= the battery connector is disconnected	• [B]= connect the batteries to the machine
	• [B]= the batteries are flat	• [B]= recharge the batteries
	• [C]= the machine plug is disconnected from the mains	• [C]= plug the machine
The brushes do not turn	• the brush switch is at the position "0"	• turn the brush switch to position "1"
	• [BT]= the brush button has not been pressed	• press the brush button
	• the brush lever is not pressed	• press the brush lever
	• [B]= the brush motor thermal protection has tripped: the motor has become overheated	• [B]= release the brush lever, turn the brush switch to position "0" (off), letting the machine cool down for at least 45'
	• [B], [BT]= = the power supply connector or the motor thermal protection connector are disconnected	• [B], [BT]= = connect again the power supply connector or the motor thermal protection connector
	• [C]= the motor power supply connector is disconnected	• [C]= connect again the motor power supply connector
	• [B], [BT]= = the brush motor fuse has blown	• [B], [BT]= = check and remove the causes that made the fuse blow, then replace it
	• [B], [BT]= = the batteries are flat	• [B], [BT]= = recharge the batteries
	• the gearmotor is broken	• have the gearmotor replaced
	• the motor is faulty	• have the motor replaced
The brush motor has trouble in starting (in <i>models with cable</i> only)	• you are working with a dry brush on a very rough floor	• turn on the detergent solution cock
	• you are working with extensions having an inadequate section on the power supply cable, or the voltage is sensibly lower than that intended for the scrubber (15% less)	• avoid the use of inadequate extensions. Increase the section of the electric wires and find out sockets with a higher voltage
	• the motor is faulty	• have the motor replaced
The machine does not wash evenly	• the brush or abrasive disc is worn	• replace them
The solution does not come out	• the cock control lever is at the position "CLOSED"	• move the lever to the position "OPEN"
	• the solution tank is empty	• fill it up

	<ul style="list-style-type: none"> • there is an obstruction in the tube through which the solution is pumped to the brush • the tap is dirty or does not work 	<ul style="list-style-type: none"> • remove the clogging, cleaning the ducts • clean or replace the tap, unscrewing the screw ref. 1 in fig. 11
The flow of solution keeps coming to the brush	<ul style="list-style-type: none"> • the tap remains open, because it is damaged or very dirty 	<ul style="list-style-type: none"> • have the tap cleaned or replaced
The suction motor does not work	<ul style="list-style-type: none"> • the suction unit switch is at the position '0' (off) • the suction motor is not fed or is faulty 	<ul style="list-style-type: none"> • operate the suction unit switch • check that the motor power supply connector is connected to the main wiring in the right way; in the second case have the motor replaced
	<ul style="list-style-type: none"> • [B], [BT]= = the fuse has blown 	<ul style="list-style-type: none"> • [B], [BT]= = replace the fuse
The squeegee does not clean or suck well	<ul style="list-style-type: none"> • the edge of the rubber blades in contact with the floor is rounded off • there is an obstruction or damage in the squeegee or in the tube • the float has intervened (recovery tank full), or is blocked by dirt or broken • there is an obstruction in the suction tube • the suction tube is not connected to the squeegee or is damaged • the suction unit motor is not fed or is faulty 	<ul style="list-style-type: none"> • replace the rubber blade • remove the obstruction and repair the damage • empty the recovery tank or make the necessary repairs to the float • free the tube from the obstruction • connect or repair the tube • check that the motor power supply connector is connected to the main wiring in the right way and that the protection fuse has not blown; in the second case replace the motor
The machine does not move forward	<ul style="list-style-type: none"> • the brush/drive motor is not fed or is faulty 	<ul style="list-style-type: none"> • in the first case set the brush switch to "1" and press the brush/drive lever; in the second case check that the brush/drive motor is connected to the main wiring in the right way; in the third case replace the motor
	<ul style="list-style-type: none"> • the gearmotor is broken (therefore, the brush does not turn) • the thermal protection of the brush motor has tripped: the motor has become overheated • [B], [BT]= = the batteries are flat and the brush safety lock-out has cut in 	<ul style="list-style-type: none"> • have the gearmotor replaced • stop the machine and switch it off, letting it cool down for at least 45' • [B], [BT]= = recharge the batteries
The machine tends to swerve to one side	<ul style="list-style-type: none"> • the floor requires an adjustment on the direction adjusting knob 	<ul style="list-style-type: none"> • adjust the advance direction acting on the speed adjusting knob

<p>The batteries do not ensure the normal work time (<u>models with battery</u> only)</p>	<ul style="list-style-type: none"> the poles and charging clips of the batteries are dirty and oxydized 	<ul style="list-style-type: none"> clean and grease the poles and clips, recharge the batteries
	<ul style="list-style-type: none"> the electrolyte level is low 	<ul style="list-style-type: none"> add distilled water topping up all elements according to the instructions
	<ul style="list-style-type: none"> the battery-charger does not work or is unsuitable 	<ul style="list-style-type: none"> see instructions relative to the battery-charger
	<ul style="list-style-type: none"> there are considerable differences in density between the various elements of the battery 	<ul style="list-style-type: none"> replace the damaged battery
	<ul style="list-style-type: none"> the machine is working with a too high pressure on the brush 	<ul style="list-style-type: none"> reduce pressure on the brush

<p>The storage battery gets flat too fast during use, although it has been charged in the correct way and when tested with a densimeter at the end of recharging, it turned out to be uniformly charged (<u>models with battery</u> only)</p>	<ul style="list-style-type: none"> the storage battery is new and does not give 100% of its expected capacity 	<ul style="list-style-type: none"> it is necessary to "run-in" the storage battery by 20-30 charges and discharges to obtain maximum performance
	<ul style="list-style-type: none"> the machine is used at its maximum capacity for continuous periods and the autonomy is not sufficient 	<ul style="list-style-type: none"> use, if possible, storage batteries with larger capacity or replace the storage batteries with others already charged
	<ul style="list-style-type: none"> the electrolyte has evaporated and does not cover the plates completely 	<ul style="list-style-type: none"> add distilled water, topping up all elements until the plates are covered and recharge the storage battery

<p>The storage battery gets flat too fast during use, the recharging with an electronic battery-charger is too fast and at the end the storage battery gives the right voltage (about 2,14V for each empty element), but it turns out to be not uniformly charged when tested with densimeter (<u>models with battery</u> only)</p>	<ul style="list-style-type: none"> the storage battery, already filled with acid by the Manufacturer, has been stored for a too long time before being recharged and used for the first time 	<ul style="list-style-type: none"> if the recharging with a normal storage-charger is not effective, it is necessary to carry out a double recharging consisting in: <ul style="list-style-type: none"> - a slow recharging of about 10 hours with a current equal to 1/10 of the rated capacity expressed in 5 hours (ex.: for a storage battery of 100Ah(5), the current should be 10A, realized by a manual battery-charger); - one-hour pause; - charging with a normal battery-charger
--	---	--

<p>After recharging with an electronic battery-charger the storage-battery does not show the correct voltage (about 2,14V for each empty element) and only one or few elements turn out to be flat when tested with densimeter (<u>models with battery only</u>)</p>	<ul style="list-style-type: none"> the storage battery has not been connected to the battery-charger (for instance because the low voltage connector of the battery-charger has been erroneously connected to the machine connector) 	<ul style="list-style-type: none"> connect the battery-charger to the storage battery connector
	<ul style="list-style-type: none"> the battery-charger and the power socket to which the storage battery is connected are not compatible 	<ul style="list-style-type: none"> check that the power supply characteristics indicated on the battery-charger plate are compliant with those of the mains
	<ul style="list-style-type: none"> the battery-charger has not been installed correctly 	<ul style="list-style-type: none"> taking into account the actual voltage available at the socket, check that the connections of the transformer primary circuit in the battery-charger are correct (at this purpose read the manual to the battery-charger)
	<ul style="list-style-type: none"> the battery-charger does not work 	<ul style="list-style-type: none"> check that there is voltage at the battery-charger, that the fuses are not interrupted and that there is current at the storage battery; in addition try to charge by means of another rectifier: if the battery-charger does not work, call the after-sales service staff communicating the serial number of the battery-charger

<p>After recharging with an electronic battery-charger the storage-battery does not show the correct voltage (about 2,14V for each empty element) and only one or few elements turn out to be flat when tested with densimeter (<u>models with battery only</u>)</p>	<ul style="list-style-type: none"> one or more elements are damaged 	<ul style="list-style-type: none"> replace, if possible, the damaged elements. For monoblock storage batteries at 6V or 12V, replace the whole storage battery
---	--	---

<p>The electrolyte that is present in the storage battery has a cloudy colour) (<u>models with battery only</u>)</p>	<ul style="list-style-type: none"> the storage battery has completed the charge/discharge cycles indicated by the Manufacturer 	<ul style="list-style-type: none"> replace the storage battery
	<ul style="list-style-type: none"> the storage battery has been recharged with a too high current 	<ul style="list-style-type: none"> replace the storage battery
	<ul style="list-style-type: none"> the storage battery has been charged beyond the limit suggested by the Manufacturer 	<ul style="list-style-type: none"> replace the storage battery

ALARMS ON THE DISPLAY:

- 1)**ACC** "drive lever" pressed when the machine is turned on or after an emergency
- 2)**SIC** Emergency button pressed
- 3)**POT** Speed potentiometer fault
- 4)**MOS** Board (mosfet) short circuit
- 5)**HOT** Motor thermal cutout tripped
- 6)**LIM** Board (mosfet) thermal limitation problem
- 7)**BLT** Drive block. Appears when the battery voltage is too low and the drive is blocked.
- 8)**AcS** Brush Control Fault. Appears when there is a fault in the solenoid switch controlling the brushes.
- 9)**AcA** Suction Control Fault. Appears when there is a fault in the solenoid switch controlling suction.
- 10)**FuP** Fuse. Appears when the fuse is blown.