



Clemas & Co Ltd

Industrial Cleaning Equipment
Sales - Hire - Service

Orbis Solaris Operator Instructions



Units A3 & A4 Northway Trading Estate, Northway Lane,
Tewkesbury, Gloucestershire, GL20 8JH.

Tel: 01684 850777

Fax: 01684 850707

Email: info@clemas.co.uk

Web: www.clemas.co.uk

User instructions

Solaris - SSD400

Scrubber / dryer: floor cleaning machine

CAUTION - READ THESE INSTRUCTIONS BEFORE USING THE MACHINE

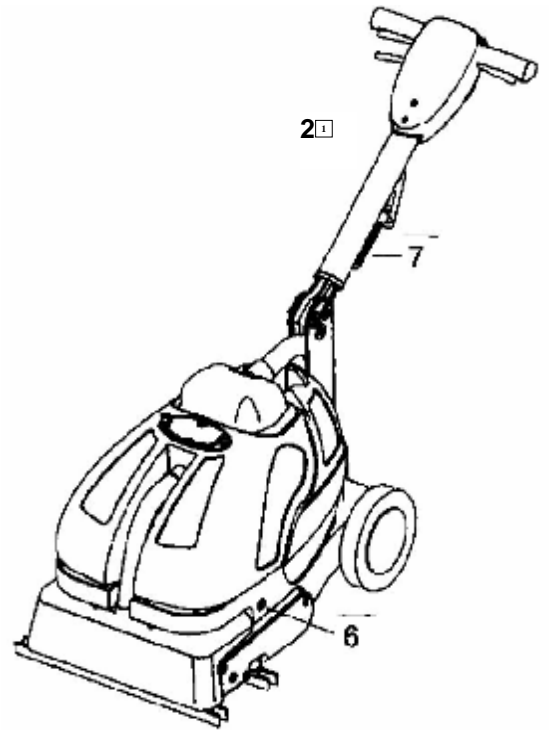
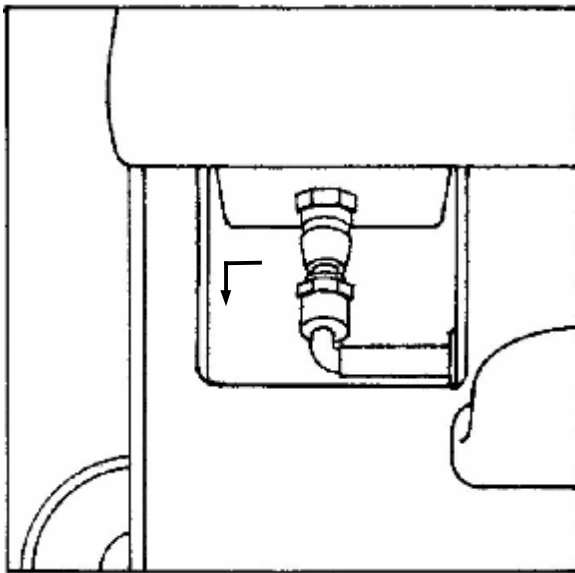
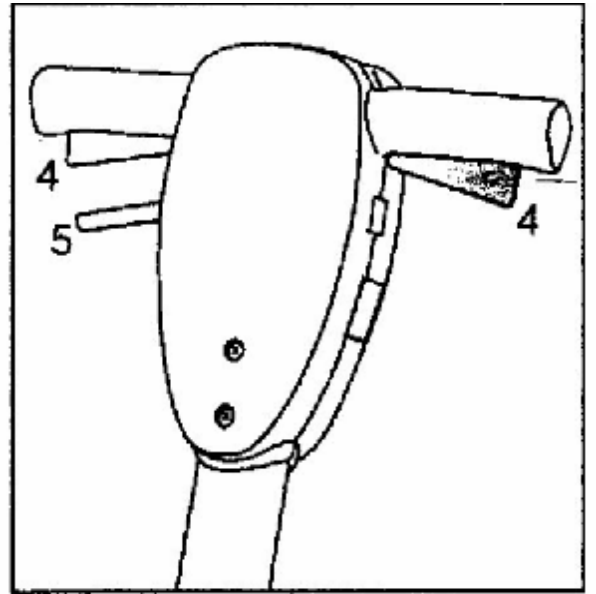
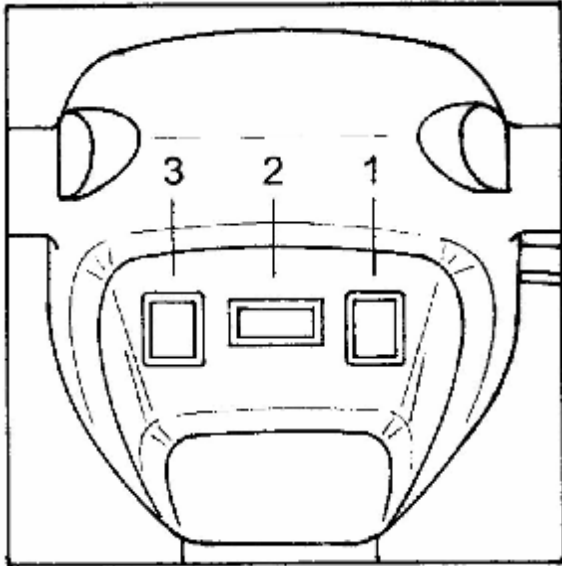

3

4

Contents

	Page
1 Product information	5
1.1 Important safety advice	5
1.2 Guidelines for the operator	5
1.3 Transporting the machine	5
2 Preparing for use	5
2.1 Electrical connection	5
2.2 Adjusting the handle height	5
2.3 Filling the solution tank	5
3 Controls	6
4 Operation	6
4.1 Starting the machine	6
4.2 Changing the brush	6
4.3 Changing squeegee blades	6
4.4 When cleaning is finished	6
5 Storage	7
6 Maintenance	7
7 After sales service	7
8 Guarantee	7
9 Technical specification	8
10 Accessories	9
10.1 Fitting the side brush	9
11 Fault diagnosis	9
12 Declaration of conformity	10

Copies of all Truvox user instructions can be downloaded from www.truvox.com

IMPORTANT

READ THESE INSTRUCTIONS CAREFULLY AND RETAIN FOR FUTURE REFERENCE

1 Product information

This commercial floor cleaning machine is especially suited for use in schools, hospitals, factories, food industry, kitchens, retail shops and stores, offices and rental businesses.

The incorporation of modern manufacturing processes ensures years of trouble free service.

The following instructions contain important information about the machines and safety advice for the operator.

Equipment must be operated, serviced and maintained in accordance with the manufacturer's instructions.

If in doubt contact the supplier of your machine.

1.1 Important Safety Advice

When using electrical equipment basic safety precautions should be followed including the following.

- Read all instructions carefully before use.
- Keep children and unauthorised persons away from the machine when in use.
- **Do not** leave the machine connected to the electricity supply when not in use, always remove the plug from the socket-outlet.
- Switch off the machine before removing the plug.
- When unplugging pull the plug, not the supply cord.
- Keep the power supply cord clear of moving parts. During operation hazard may occur when running the machine over the power supply cord.
- **Do not** operate the machine with a damaged supply cord or plug, or after the machine malfunctions or is damaged in any way. Contact an authorised Service Agent for repair or adjustment.
- The plug of the power supply cord must be removed from the socket-outlet before commencing cleaning of the machine or undertaking maintenance operations.
- The power supply cord must be regularly inspected for signs of damage. If the power supply cord is damaged, it has to be replaced.
- **Do not** use where hazardous dust is present.
- **Do not** use in an explosive atmosphere.
- Take care when using a machine near the top of stairs to avoid overbalancing.

1.2 Guidelines for the operator

- Operators must be fully trained in the use of the machine in accordance with these instructions, able to perform user maintenance and the correct selection of accessories, i.e. brushes.
- Operators should be physically capable to manoeuvre, transport and operate the machine.
- Operators should be able to recognise unusual operation of the machine and report any problems.
- Keep hands and feet well clear of the rotating brush.

- Wear suitable footwear to avoid slipping.
- Wear suitable clothing to keep dry and warm.
- Where possible implement job rotation and adequate rest periods to avoid continuous use of the same muscles.
- **Do not** smoke when using the machine.
- **CAUTION** - This machine is for indoor use only and should not be used or stored outdoors or in wet conditions.

1.3 Transporting the machine

CAUTION - THIS MACHINE IS HEAVY

Do not attempt to lift the machine without assistance. Incorrect lifting techniques may result in personal injury. We recommend two people lift the machine using a lifting point at the front and rear. **Do not lift the machine by the handle.**

To minimise the weight and avoid spillage of liquid empty both water tanks before lifting.

To move the machine to the work area, lock the handle and tilt it backwards to raise the front off the floor, and wheel into position.

2 Preparing for use

2.1 Electrical connection

Before connecting the machine to the power supply, check that your supply voltage corresponds with that marked on the rating label on the rear of the machine.

UK only

The supply cord is fitted with a non rewirable plug containing a 13 amp fuse. Should the fuse require replacement it must only be replaced by a 13 amp fuse conforming to BS1362, and the fuse cover must be refitted. If the fuse cover is lost the plug **must not** be used until the correct replacement cover is fitted.

IMPORTANT - If the supply cord is damaged, it must only be replaced by a special cord available from the manufacturer or an authorised service agent.

Should an extension cord be used, ensure cord rating is adequate for the equipment. **Do not** use extension cord in coiled condition as this could result in overheating of the cord.

WARNING - THIS APPLIANCE MUST BE EARTHED

2.2 Adjusting the handle height

Select the most comfortable handle height using the adjustment lever on the handle, and lock in position.

2.3 Filling the solution tank

- The solution tank can be filled on or off the machine. To fill the tank off the machine the recovery tank must first be removed.
- Remove vacuum hose and clear dome from recovery tank and lift off tank.
- Disconnect solution feed hose from solution tank and lift tank off base. To release hose pull connector collar forward (Fig.3).

- Fill the solution tank with clean water using a bucket, tap or hose, and an appropriate measure of detergent.
- Replace tanks on base and reconnect hoses. Ensure solution hose is fully engaged and captive in the connector allowing solution to flow, thus preventing the pump from overheating.
- **IMPORTANT** - Only chemicals recommended by the appliance manufacturer should be used, i.e. low foaming, and follow the chemical manufacturer's directions regarding use, handling, disposal and health and safety provisions.
- The tank capacity is 15 litres. Do not overfill the tank as spillage may occur when in use.
- **IMPORTANT** - When the solution tank has emptied, switch off the machine and empty the recovery tank before refilling the solution tank.

3 Controls

The operating controls are located on the handle (Figs.1&2).

1 - Brush motor switch

Used to switch motor ON and OFF. Lights when in the on position.

2 - Neon indicator

Lights when the machine is connected to the power supply.

3 - Vacuum motor switch

Used to switch motor ON and OFF. Provides suction at the squeegee. Lights when in the on position.

4 - Solution feed triggers

When squeezed supplies cleaning solution to the brush head.

5 - Handle adjustment lever

Used to adjust handle to comfortable working height.

6 - Cut-out reset button

Cut-out protects brush motor from overheating. Press button once to reset cut-out and restart motor.

7 - Cable winder

Used to hold supply cord in place on handle when machine is not in use.

4 Operation

4.1 Starting the machine

- Fully unwind the supply cord and plug in to a convenient socket outlet.
- With the solution tank filled and the handle set at a comfortable height, the machine is ready for use.
- Switch ON the brush motor, followed by the vacuum motor.
- Release cleaning solution at regular intervals by means of the handle triggers.
- **WARNING** - Always ensure adequate solution is on the floor, scrubbing without solution could damage the floor surface and/or the machine brush. Keep the machine moving while the brush is rotating.

- **IMPORTANT** - Should the brush stop rotating due to operation of the cut-out on the brush motor, switch OFF the machine and allow to cool for a few minutes. Press the cut-out reset button on left hand side (Fig.4), and restart the machine.
- **WARNING** - If foam or liquid is emitted, **switch off immediately** and empty recovery tank. Liquid emitted could be hazardous as a result of its temperature, or chemical content.
- To STOP the machine, release solution feed triggers, switch off brush motor then vacuum motor.
- Normal movement of the machine is in a **forward and backward** direction.
- Proceed to operate the machine in the normal manner, releasing cleaning solution from time to time as required.
- For heavy soilage, scrub floor with cleaning solution but with vacuum motor OFF. Scrub floor again picking up the solution.
- When scrubbing is complete, unplug the machine from the power supply, empty the solution tank and clean and dry the machine.
- **IMPORTANT** - Dispose of unused cleaning solution in accordance with the manufacturer's directions.

4.2 Changing the brush

WARNING - This appliance has been designed for use with the brushes specified by the manufacturer. The fitting of other brushes may affect its safety.

Always ensure machine is unplugged before fitting or removing parts.

- To change the brush, first remove both recovery tank and solution tank to reduce weight and avoid spillage.
- Move handle to upright position, pull backwards and downwards to rest on the floor thereby raising the base.
- Push end of brush shaft with a finger and withdraw shaft completely.
- Place new brush in position and insert shaft through brush until it clicks into place.
- Return machine to the floor, replace tanks and reconnect hoses etc.

4.3 Changing squeegee blades

The squeegee blades are self adjusting for wear, however when wet pick-up becomes ineffective, or blades are damaged they should be replaced as follows.

- Raise machine base as for a brush change.
- Slide squeegee blades out sideways from the holder.
- Slide new blades into place with the ribbed side facing outwards.
- Return machine to the floor.

4.4 When cleaning is finished

- When cleaning is finished, unplug the machine from the power supply, and lift off and empty the recovery and solution tanks over a suitable sink or drain.

- Flush out the recovery tank with clean water. Replace tanks and wipe over the machine with a damp cloth.
- Wipe squeegee blades clean.
- **IMPORTANT** - Dispose of unused cleaning solution in accordance with the manufacturer's directions.
- Remove brush and wash in warm soapy water, rinse and allow to dry naturally.

5 Storage

After use always wipe down and dry the machine, and remove and clean the brush.

The solution tank and recovery tank should be emptied and flushed out with clean water.

When storing the machine for long periods, raise the base to protect the brush and squeegee from possible distortion.

Wrap supply cord around the handlebar and cable winder ensuring that the plug is not trailing on the floor. Fold handle down as necessary. Store the machine in a dry indoor area only.

6 Maintenance

WARNING - Before undertaking maintenance operations or adjustments switch off machine and unplug from the electricity supply.

The machine requires minimum maintenance apart from the following checks by a trained operator.

- **Supply cord** - Regularly inspect sheath, plug and cord anchorage for damage or loose connection. Only replace the supply cord with the type specified in these instructions.
- **Solution tank** - Check water flow, if restricted inspect tubing for blockage. Check filter is clean and undamaged. A damaged filter must be replaced.
- **Recovery tank** - Check condition and clean tank.
- **Squeegee blades** - Check condition and replace worn or damaged blades.
- **Solution spray bar** - Remove the brush to access the spray bar. Check that the solution feed holes are not blocked or restricted, and clean as necessary.

7 After sales service

Should you require after sales service please contact the supplier from whom you purchased the machine, who will arrange service. Repairs and servicing of Truvox products should only be performed by trained staff. Improper repairs can cause considerable dangers to the user.

8 Guarantee

Your product is guaranteed for one year from the date of original purchase, or hire purchase, against defects in materials or workmanship during manufacture.

Within the guarantee period we undertake at our discretion, to repair or replace free of charge to the purchaser, any part found to be defective, subject to the following conditions.

CONDITIONS

1. Claims made under the terms of the guarantee must be supported by the original invoice/bill of sale issued at the time of sale, or the machine Serial No.
2. For claims under this guarantee contact the supplier from whom you purchased the product who will arrange the appropriate action. Do not initially return the product as this could result in transit damage.
3. Neither Truvox nor its distributor shall be liable for any incidental or consequential loss.
4. This guarantee is governed by the laws of England.
5. This guarantee does not cover any of the following:
 - Periodic maintenance, and repair or replacement of parts due to normal wear and tear.
 - Damage caused by accident, misuse or neglect, or the fitting of other than genuine Truvox parts.
 - Defects in other than genuine Truvox parts, or repairs, modifications or adjustments performed by other than a Truvox service engineer or authorised service agent.
 - Costs and risks of transport relating directly or indirectly to the guarantee of this product.
 - Consumable items such as, brushes, squeegee blades, belts and filters.

This guarantee does not affect your statutory rights, nor your rights against the supplier arising from their sales or purchase contract.

Truvox International Limited has a policy of continual product development and we reserve the right to alter specifications without prior notice.

9 Technical specification

Machine is of Class I construction. Enclosure to IPX4. Fitted with 15m supply cord type H05VV-F, 3 x 1.0 mm² (10A), and non rewirable plug.

Model		SSD400
Voltage ~ 50 Hz.	V	230-240
Running current	A	6
Brush width	cm	40
Brush diameter	cm	10
Brush speed	rpm	750
Brush pressure (max)	g/cm ²	30
Squeegee width	cm	51
Solution tank capacity	ltr	15
Recovery tank capacity	ltr	15
Productivity - theoretical	m ² /h	1200
Productivity - practical	m ² /h	500
Brush motor rating	W	150
Vacuum motor rating	W	1100
Airflow	ltr/sec	43
Vacuum	mm/wg	2300
Pump rating	W	42
Solution flow rate	ltr/min	0,65
Pump pressure (max)	MPa	0,22
Sound pressure level (see note 1)	dB(A)	< 70
Handle vibration (see note 2)	m/s ²	< 2.5
Length	cm	75
Width	cm	50
Height (handle folded)	cm	60
Weight (empty)	kg	37

1 - Sound pressure level measured at a distance of 1 metre from machine and 1,6 metres above floor, when scrubbing a hard floor. Measurements recorded using a hand held meter.

2 - Handle vibration does not exceed 2,5 m/s², when operating on any surface with brush or pads. Measurements recorded by an independent test laboratory.

10 Accessories

Item	Qty	Part No.	Application
Standard brush (Black)	1	03-7869-0000	General purpose scrubbing
Heavy duty brush (Blue))	1	03-7916-0000	Heavy duty scrubbing
Squeegee kit (2 blades)	1	10-0040-0000	Wet pick-up
Side brush kit	1	10-0048-0000	Cleaning close to walls

IMPORTANT : Genuine accessories are only available from authorised Service Agents or Truvox Customer Service Dept.

10.1 Fitting the side brush

Always ensure machine is unplugged before fitting or removing parts.

- Remove recovery and solution tank, and raise machine base as for a brush change.
- Remove shaft from brush and position the magnetic brush guard on right hand side of machine, locating the peg on the guard in the hole in the side plate, and align the shaft hole.
- Insert side brush shaft through guard and push right through main brush until it clicks into place.
- Return machine to floor, replace tanks and reconnect hoses.

11 Fault diagnosis

The following simple checks may be performed by the operator.

Fault	Reason	Remedy
Machine not working, motors not running.	Lack of voltage/electrical supply.	Check fuse *, supply cord, plug and socket outlet.
Vacuum motor not running, switch illuminated.	Faulty motor.	Contact Service Agent.
Brush motor running, but brush not rotating.	Brush shaft incorrectly positioned. Loose or broken drive belt.	Refit shaft. Contact Service Agent.
Cleaning solution not flowing.	Solution hose not correctly fitted to tank connector. Hose blocked Waterways in spray bar blocked. Solution tank empty. Blocked filter in solution tank. Damaged pump.	Check connection is secure. Check and clear hose.. Check and clean spray bar. Refill tank. Check and clean filter. Contact Service Agent.
Vacuum motor running but squeegee not picking up.	Hose from squeegee blocked or split. Squeegee slot blocked or blades damaged. Vacuum dome out of position.	Check and clear hose. Check and clean squeegee. Reposition dome.

* If the fuse blows several times, the machine should be checked by an authorised Service Agent.

EC Declaration of conformity

We, Truvox International Ltd.

of Third Avenue
Millbrook Trading Estate
Southampton SO15 0LE
England

declare that the machinery

Make : Scrubber / Dryer
Type : Solaris
Model : SSD400

Serial Number :
Year of Construction : 2004

has been manufactured using the following transposed harmonized European Standards and technical specifications.

BS EN 60335-1 and BS EN 60335-2-68

and is in conformity with EC Directives, 98/37/EC, 73/23/EEC and 89/336/EEC and all amendments.

Signed in : SOUTHAMPTON, England

on the 26th day of April 2004

Signature :

Name : M R Eneas
Position : New Product Development Manager

