

Clemas & Co Ltd

Industrial Cleaning Equipment
Sales - Hire - Service

CR38 CYCLONE THREE BRUSH SCRUBBER PARTS MANUAL



Clemas & Co. Unit 5 Ashchurch Business Centre, Alexandra Way, Tewkesbury,
Gloucestershire, GL20 8NB.

Tel: 01684 850777

Fax: 01684 850707

Email: info@clemas.co.uk

Web: www.clemas.co.uk

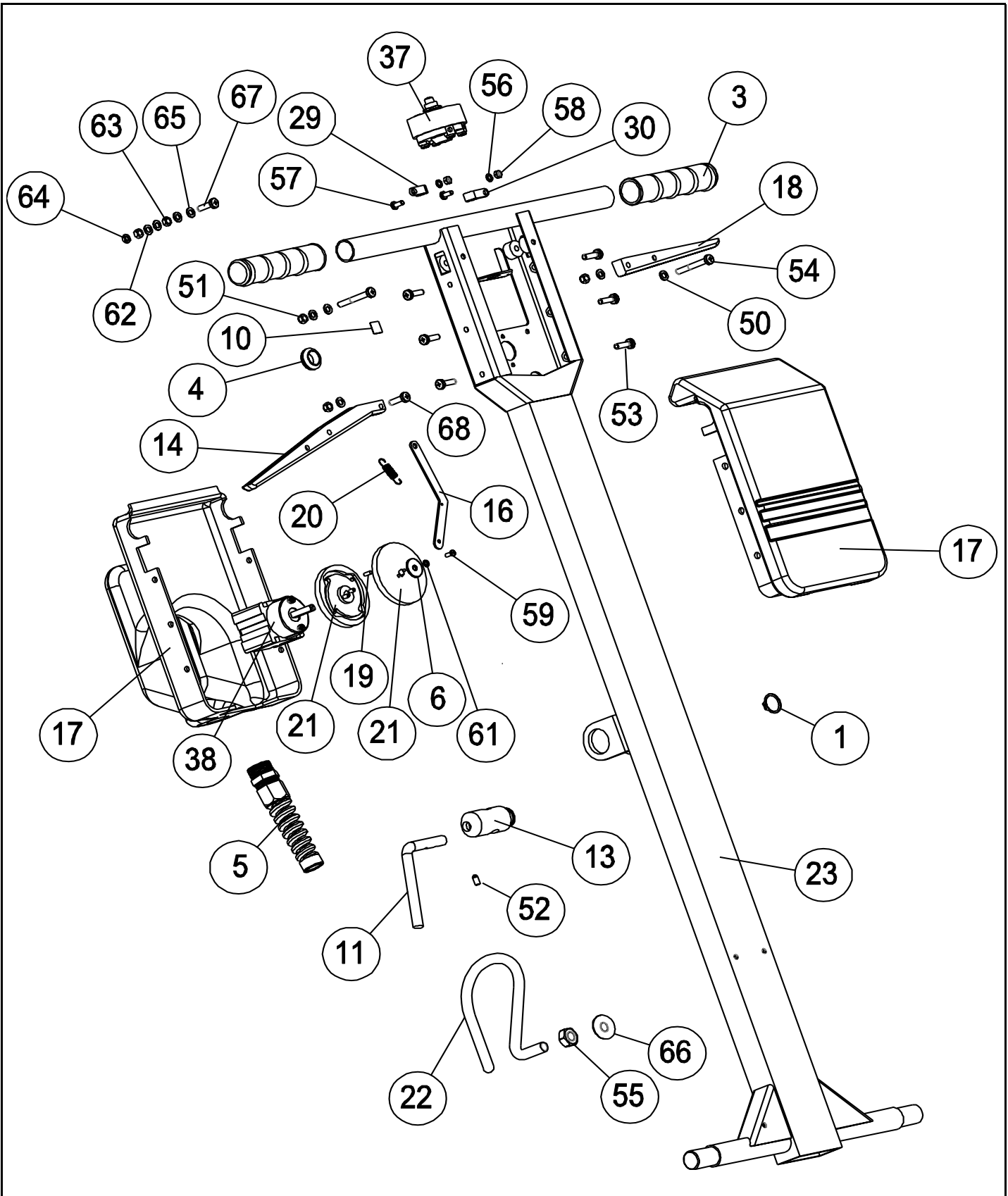

Tacony CFC

CR38 Handle Assembly

Drawing Number: 09-1047-0000

Date:	2/3/2009		
Machine:	CR38		
Reference Parts List:	05-3987-0000		
Modified By:	G SECHERE	DESCRIPTION OF CHANGE	
Revision:	B		
		COMPONENTS CHANGE	ECN # N/A

Tacony CFC		CR38 Handle Assembly	
Part Reference: 05-3987-0000			
Date:	2/3/2009		
Machine:	CR38		
Reference Drawing Number:	09-1047-0000		
Modified By:	G SECHERE	DESCRIPTION OF CHANGE	ECN #
Revision:	B	COMPONENTS CHANGE	N/A

Ref. No.	Part No.	Part Description	Qty
CORE COMPONENTS			
1	02-3950-0000	3/4 in EXTERNAL CIRCLIP	1
2	02-4065-0000	SLEEVING 2MM CLEAR	4"
3	02-4175-0000	HANDLE GRIP	2
4	02-4176-0000	GROMMET	1
5	02-4186-0000	CABLE GLAND	1
6	02-4311-0000	PENNY WASHER	1
7	02-4149-0000	TYRAP - SMALL (BI) *NOT SOWHN*	7
10	03-6185-0000	EARTH POINT LABEL	1
11	03-6953-0000	LOCKING HANDLE	1
13	03-6957-0000	PIVOT	1
14	03-7281-0000	LEVER	1
16	03-7298-0000	SWITCH CAM LEVER	1
17	03-7300-1000	HANDLE BOX (FRONT & REAR SET)	1
18	03-7301-0000	WATER VALVE LEVER	1
19	03-7433-0000	CAM FOLLOWERS	1
20	03-7434-0000	SPRING	1
21	03-7435-0000	REVERSE SWITCH CAMS	1
22	03-7660-0000	CABLE HOOK	1
23	03-8010-0000	CR38 COMMON HANDLE FRAME	1
29	04-0286-0000	P CLIP (DROPLEAD)	1
30	04-0286-0000	P CLIP (MAINS CABLE)	1
31	04-3416-0000	SUPPRESSOR RF 0.47UF	1
33	04-3576-0000	CRIMP TERMINAL PRE-INSULATED *NOT SHOWN*	6
32	04-3480-0000	TERMINAL (FORK) *NOT SHOWN*	2
34	04-3481-0000	TERMINAL (SPRING SPADE) *NOT SHOWN*	4
35	04-3602-0000	TERMINAL (RING) *NOT SHOWN*	2
36	04-3055-0053	MAINS CABLE 1.5MM SQ ORANGE PVC 3 CORE UK PLUG	1
37	04-3686-0000	SWITCH (MOMENTARY)	1
38	04-3809-0000	SWITCH (CAM OPERATED)	1
43	04-3553-0000	CABLE 2.5MM 14AWG BLACK *NOT SHOWN* (DROPLEAD)	174"
44	04-3556-0000	CABLE 2.5MM 14AWG BLUE *NOT SHOWN* (DROPLEAD)	87"
45	04-3558-0000	CABLE 2.5MM 14AWG BROWN *NOT SHOWN* (DROPLEAD)	87"
46	04-3559-0000	CABLE 2.5MM 14AWG GREEN/YELLOW *NOT SHOWN* (DROPLEAD)	87"
47	72470A	HEAT SHRINK TUBING	12"
FASTENERS			
50	00-0500-0503	M5 PLAIN WASHER	6
51	00-0500-0723	M5 NYLOC NUT	3
52	00-0510-0171	M5 x 10 SOCKET SET SCREW	1
53	00-0512-0013	M5 X 12 POZI PAN HEAD SCREW	6
54	00-0540-0013	SCREW, M5 X 40 PAN HEAD	2
55	00-1000-0703	M10 FULL NUT	1
56	00-0400-0523	M4 SHAKEPROOF WASHER	2
57	00-0410-0023	M410 POZI PAN HEAD	2
58	00-0400-0703	M4 FULL NUT	2
59	00-0308-0013	M3x8 POZI PAN HD SCREW	1
61	00-0300-0503	M3 PLAIN WASHER	1
62	00-0500-0507	M5 BRASS WASHER	3
63	00-0500-0703	M5 FULL NUT	2
64	00-0500-0713	M5 LOCK NUT	1
65	00-0500-0521	M5 SHAKEPROOF WASHER Z/P	1
66	00-1000-0523	M10 SHAKEPROOF WASHER	1
67	00-0520-0013	M5x20 POZI PAN HD SCREW	1
68	00-0518-0013	M5 X 12 POZI PAN HEAD SCREW	1

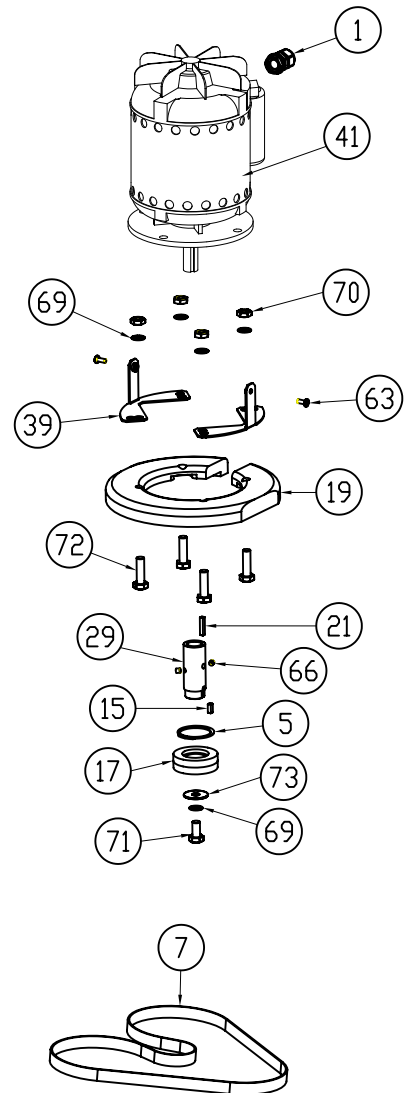
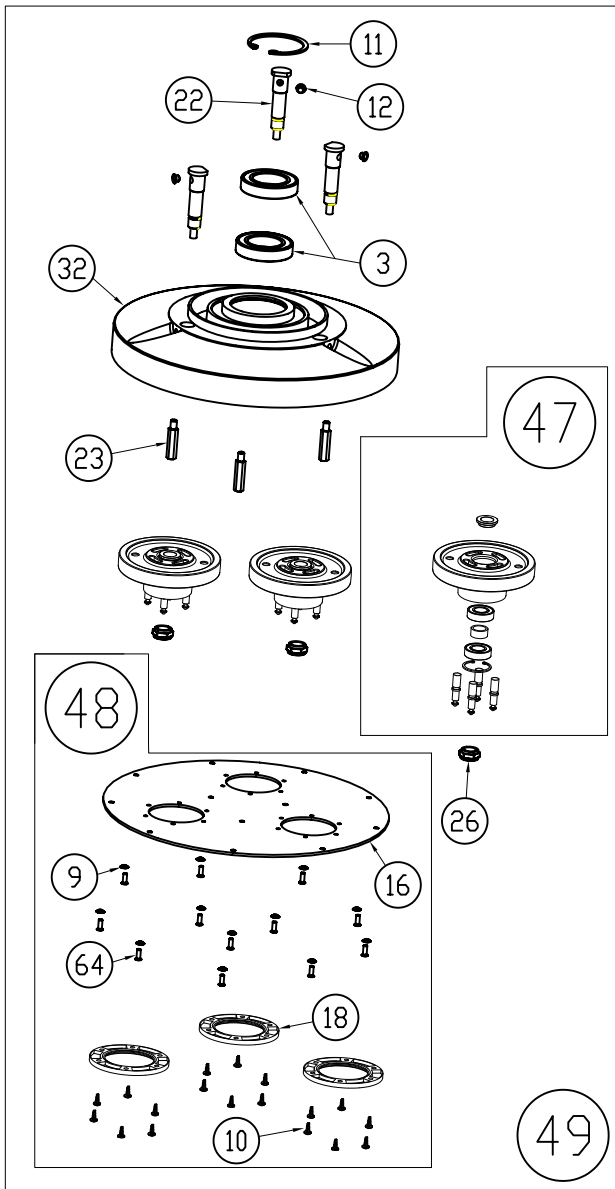
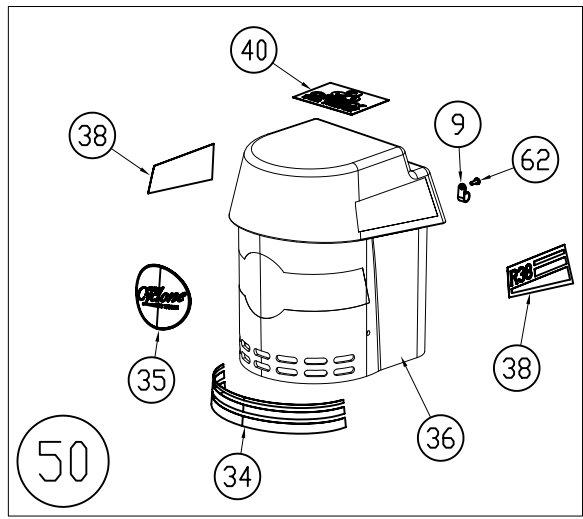
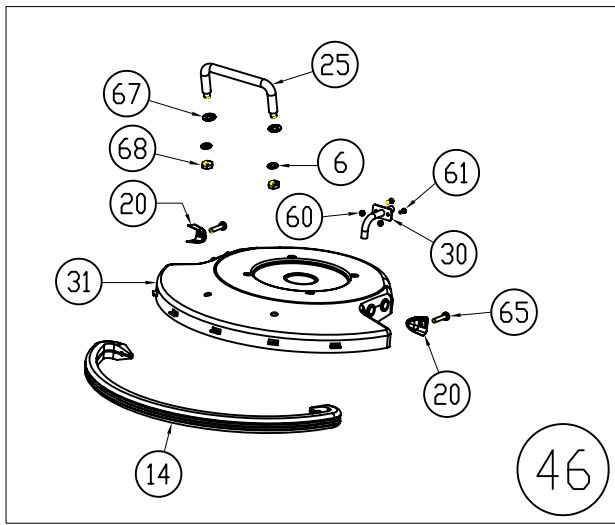

Tacony CFC

CR38 Head Assembly

DRAWING NO.: 09-1095-0000

MACHINE: CR38

REF. PARTS LIST: 05-3959-0000

SERIES: B

REVISION

ECN #

DESCRIPTION OF CHANGE

MOD. BY

DATE

A

0279

CHANGED TO LEMAC MOTOR; COVER TO 03-8230-0000

GS

2/15/2010

Tacony CFC

CR38 Head Assembly

Part Reference: 05-3959-0000

MACHINE:	CR38			
REF. DWG. #:	09-1095-0000			
SERIES:	B			
REVISION	ECN#	DESCRIPTION OF CHANGE	MOD. BY	DATE
A	0279	CHANGED MOTOR TO LEMAC; COVER TO 03-8230-0000	G.S.	2/15/2010

Ref. No.	Part No.	Part Description	Qty
CORE COMPONENTS			
1	02-3965-0000	CABLE GLAND & NUT	1
2	02-4379-0000	M10 STEEL RIVNUT TPP30 *NOT SHOWN*	4
3	02-4020-0000	BALL RACE 6009-2RS	2
5	02-4024-0000	EXTERNAL CIRCLIP 1400-45MM	1
7	02-4189-0000	BELT 1155 x 16mm NITTA LA500 (BLUE/BLUE)	1
8	02-4279-0000	P CLIP HEYCO 350-3364	1
9	02-4320-0000	BRASS CUP WASHER	12
10	02-4323-0000	N o. 12 x 1/2" PAN HD POZI S/TAP ST/ST SCREW	18
11	02-4380-0000	CIRCLIP INTERNAL 1300-75MM	1
12	02-4381-0000	(BI)PLASTIC INSERT REF 12157	3
14	03-6898-1000	BUMPER STRIP (BI)	22"
15	03-6901-0000	STEEL KEY 3/16in x 3/16in x 1/2in LONG	1
16	03-6907-0000	CR38 BOTTOM COVER PLATE	1
17	03-6908-0000	MOTOR PULLEY FINISHED MILD STEEL	1
18	03-6910-0000	DUST SEAL FULLY FINISHED	3
19	03-6911-0000	HEADWEIGHT FINISH GREY OXIDE	1
20	03-6928-0000	CLIP	2
21	03-6930-0000	ROUND END ST KEYS 3/16 X 3/16 X 25mm	1
22	03-6944-0000	BRUSH SPINDLE (BRASS)	3
23	03-7332-0000	BOTTOM COVER SPACER BZPISS C	3
25	03-7668-0000	LIFTING HANDLE	1
26	03-7220-0000	(BI)M16 NYLOC NUT FULLY MACH IN ED D RG ISS B	3
29	03-7309-0000	SHAFT EXT.(MOTOR) 38 SERIESTO DRG. ISS C	1
30	03-7313-0000	WATER INLET BRIGHT ZINC PLATE	1
31	03-7327-0000	BUMPER SHIELD PLATE AND PAINT YELLOW RAL 1018	1
32	03-7328-0000	BOWL EDU 38 SERIES ALOCROM AND PAINT BLUE RAL 5013	1
34	03-7654-0000	DECAL MOTOR COVER CYCLONE TO DRG. ISSUE'01'	1
35	03-7655-0000	DECAL MOTOR COVER CYCLONE TO DRG. ISSUE'01'	1
36	03-8230-0000	CR48 MOTOR COVER	1
38	03-7684-0000	LABEL - MOTOR COVER R38 DRG ISS 1	2
39	03-7833-0000	MOTOR COVER BRACKET	2
40	03-7944-0000	CIMEX FROM TRUVOX LABEL (LARGE 96 x 85mm)	1
41	04-3915-0000	MOTOR 370W 0.5HP 220-240V 50/60Hz	1
42	04-3602-0000	RING TERMINAL #10 *NOT SHOWN*	5
43	72470A	HEAT SHRINK 1/2 BLK *NOT SHOWN*	12"
47	05-4547-0000	CR38 BRUSH PULLEY ASSEMBLY	3
FASTENERS			
60	00-0300-0723	M3 NYLOC NUT A2	2
61	00-0308-0013	M3 X 8 PAN POZI M/C SCREW A2	2
62	02-4323-0000	10 X 1/2 PAN POZI AB S/TAPPER	1
63	00-0512-0013	M5 X 12 PAN POZI M/C SCREW A2	2
64	00-0512-0033	M5 X 12 CSK POZI M/C SREW A2	12
65	00-0525-0013	M5 X 25 PAN POZI M/C SCREW A2	2
66	00-0606-0171	M6 X 6 SKT SET SCREW S/COL	2
67	X8218+	5/16 SAE FLAT WASHER	2
68	00-0800-0713	M8 HEX LOCK NUT A2	2
69	00-1000-0523	M10 INT S/PROOF WASHER S/S	5
70	00-1000-0703	M10 HEX NUT S/S	4
71	00-1020-0123	M10 X 20 HEX SET SCREW S/S	1
72	00-1040-0111	M10 X 40 HEX SCREW BZP	4
73	02-4335-0000	M10 X 30 PENNY WASHER A2	1

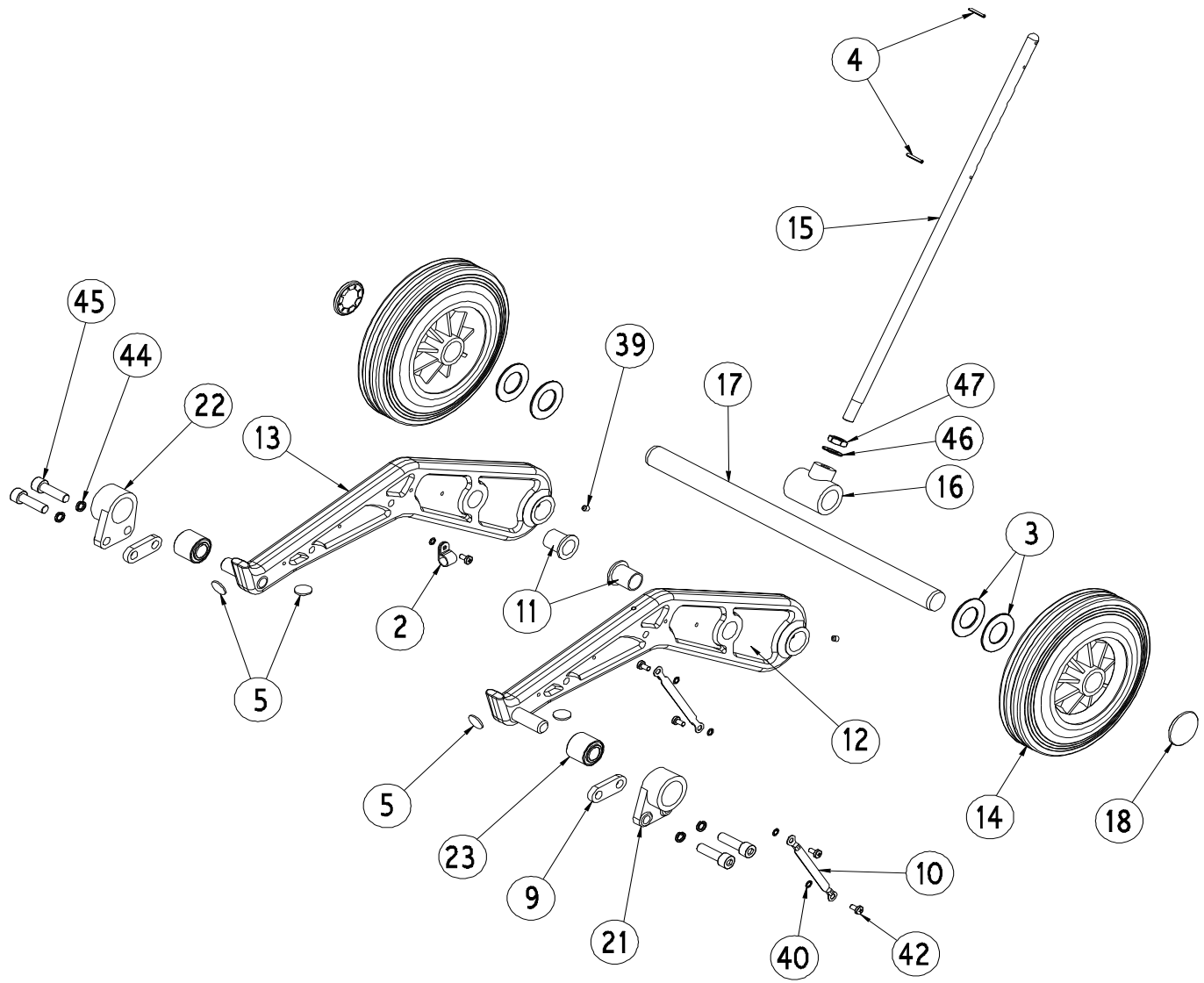

Tacony CFC

CR38 Chassis Assembly

Drawing Number: 09-1094-0000

Date:	9/14/2009		
Machine:	CR38		
Reference Parts List:	05-4531-0000		
Modified By:	G SECHERE	DESCRIPTION OF CHANGE	
Revision:	C		

Tacony CFC**CR38 Chassis Assembly****Part Reference: 05-4531-0000**

Date:	9/14/2009		
Machine:	CR38		
Reference Drawing Number:	09-1094-0000		
Modified By:	G SECHERE	DESCRIPTION OF CHANGE	ECN #
Revision:	C	ADDED SET SCREWS (#39)	0134

Ref. No.	Part No.	Part Description	Qty
CORE COMPONENTS			
2	02-4279-0000	P-CLIP 1/2" (CONDUIT)	1
3	02-4363-0000	WASHER (USED AS WHEEL SPACER SUBJECT TO QTY CHANGE)	4
4	02-4208-0000	SELLOCK PIN 1/8x7/8	2
5	02-4187-0000	BUFFER RUBBER 19mm x 1.5mm	4
9	03-7342-0000	SPACER	2
10	03-6899-0000	EARTH LEAD (WITH INTEGRAL TERMS)	2
11	03-6919-0000	FORK HANDLE BUSH (BLACK)	2
12	03-8175-0000	CR48 LIFTING FORK L/H	1
13	03-8176-0000	CR48 LIFTING FORK R/H	1
14	03-7277-0000	WHEEL 200mm DIA	2
15	03-7279-0000	SWIVEL CLAMP ROD	1
16	03-7306-0000	TEE PIECE	1
17	03-7384-0000	AXLE BZP	1
18	03-7658-0000	STARLOCK HUB CAP	2
20	02-4261-0000	16mm CONDUIT *NOT SHOWN*	36"
21	03-6926-0000	PIVOT BLOCK (L/H)	1
22	03-6925-0000	PIVOT BLOCK (R/H)	1
23	03-6929-0000	SILENT BEARING	2
FASTENERS			
39	00-0606-0171	M6 X 6 SKT SET SCREW S/COL	2
40	00-0500-0521	M5 INTERNAL SHAKEPROOF WASHER	5
42	00-0512-0013	M5x12 POZI PAN HEAD SCREW ST/ST	5
44	7CL003	M10 SPRING WASHER ST/ST	4
45	00-1030-0103	M10x30 CAP HD SCREW ST/ST	4
46	00-1200-0503	M12 WASHER FORM B ST/ST	1
47	00-1200-0713	M12 LOCKNUT ST/ST	1

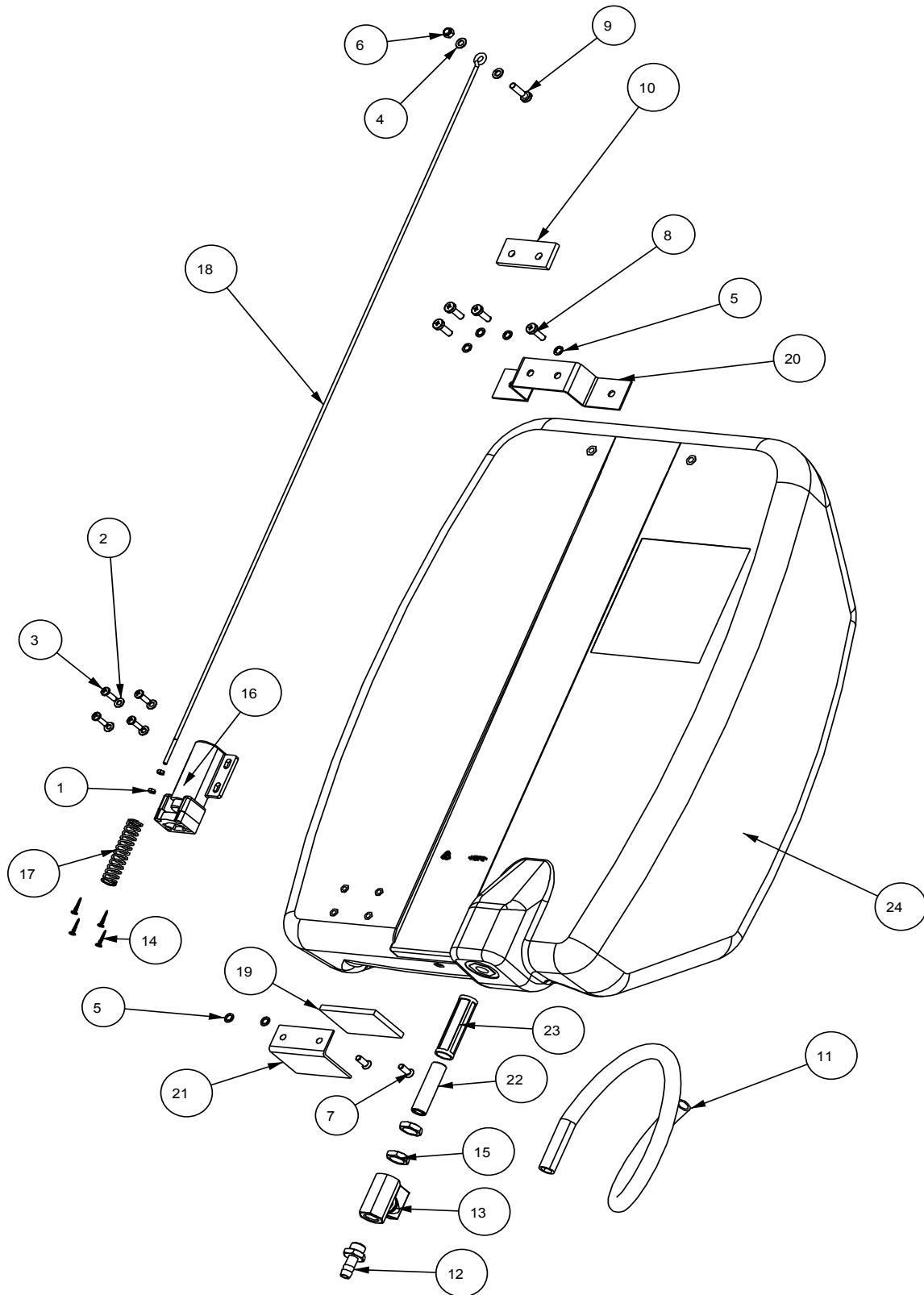

Tacony CFC

Cyclone Range Tank Assembly

Drawing Number: N/A

Date:	9/10/2009		
Machine:	CYCLONE RANGE MACHINES		
Reference Parts List:	05-4253-0000		
Modified By:	G SECHERE	DESCRIPTION OF CHANGE	ECN #
Revision:	C	INCREASED QTY OF #5 TO 6 & #8 TO 4	0135

Tacony CFC**Cyclone Range Tank Assembly****Part Reference: 05-4253-0000**

Date:	9/10/2009		
Machine:	CYCLONE RANGE MACHINES		
Reference Drawing Number:	N/A		
Modified By:	G SECHERE	DESCRIPTION OF CHANGE	ECN #
Revision:	C	INCREASE QTY OF #5 TO 6 & #8 TO 4	0135

Ref. No.	Part No.	Part Description	Qty
CORE COMPONENTS			
10	02-3278-0000	NEOPRENE ADHESIVE STRIP	4"
11	02-4179-0000	SILICON HOSE (CR TANK) 1.6M	63"
12	02-4212-0000	WATER OUTLET BRASS NICKEL	1
13	02-4213-0000	BALL VALVE	1
14	02-4360-0000	SCREW SELF TAPPER	4
15	03-3475-0000	1/4 INCH BRASS HEXNUT	2
16	03-7297-0000	WATER VALVE (BLUE)	1
17	03-7302-0000	SPRING LEE LC 0594 MWTO SPEC.ISS 01	1
18	03-7303-0000	SOLUTION TANK ROD	1
19	03-7304-0000	FOAM HANDLE PAD	1
20	03-7311-0000	TANK BRACKET TOP	1
21	03-7312-0000	SOLUTION TANK BRACKET LOWER	1
22	03-7661-0000	VALVEINSERT	1
23	03-7662-0000	FILTER (NYLON)	1
24	03-8178-0000	CR RANGE SOLUTION TANK	1
FASTENERS			
1	00-0300-0703	M3 FULL NUT ST/ST	2
2	00-0400-0503	M4 WASHER FORM 'A' ST/ST	4
3	00-0412-0013	M4 X 12 POZI PAN HEAD SCREW ST/ST	4
4	00-0500-0503	M5 WASHER FORM A ST/ST	2
5	00-0500-0521	M5 INTERNAL SHAKEPROOF	6
6	00-0500-0723	M5 NYLOC NUT ST/ST	1
7	00-0512-0033	M5 x 12 COUNTERSUNK SCREW ST/ST	2
8	00-0516-0013	M5 x 16mm POZI PAN HD SCREW ST/ST	4
9	00-0520-0013	M5 x 20 POZI PAN SCREW ST/ST	1

0.47uF SUPPRESSOR NOT FITTED TO USA VERSION, 110V 60Hz

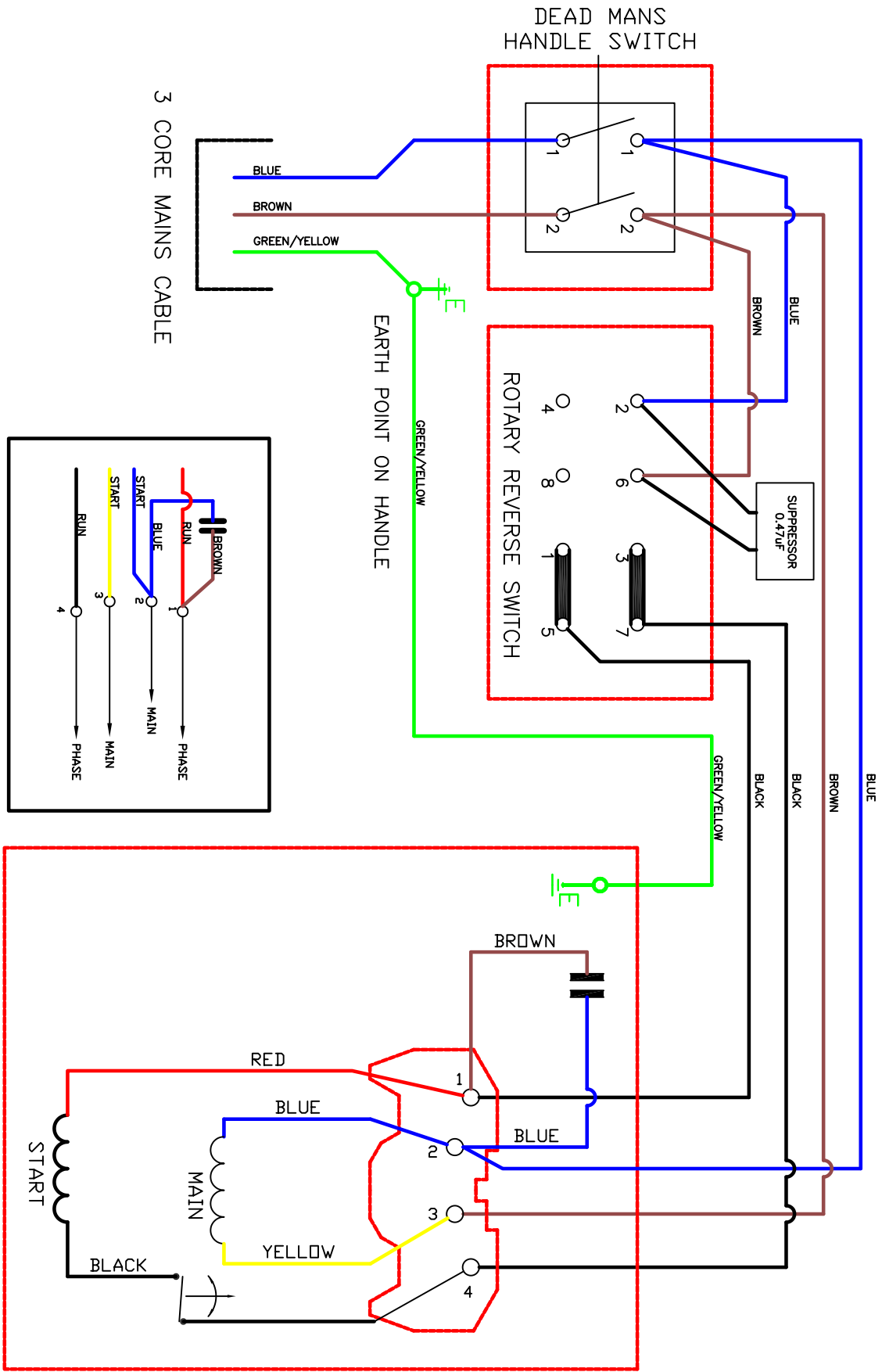

REV	DATE	ECN	DESCRIPTION	BY	MATERIAL	FINISH	SHEET
A	3/18/10	0279	NEW DRAWING	GS	GS	SCALE	

TACOONY
 COMMERCIAL FLOOR CARE
 3101 Wichita Court
 Fort Worth, TX 76140-1755
 DESCRIPTION (CIMEX) WIRING DIAGRAM CR38 DMH SWITCH
 PART NUMBER 09-1122-0000
 REV A