

Clemas & Co Ltd

Industrial Cleaning Equipment
Sales - Hire - Service

CT160 RIDE-ON SCRUBBER DRYER OPERATOR MANUAL



Clemas & Co. Unit 5 Ashchurch Business Centre, Alexandra Way, Tewkesbury,
Gloucestershire, GL20 8NB.

Tel: 01684 850777

Fax: 01684 850707

Email: info@clemas.co.uk

Web: www.clemas.co.uk

ENGLISH

(Translation of original instructions)

1. INDEX

1. INDEX	2
2. GENERAL INFORMATION	4
2.1. SCOPE OF THE MANUAL.....	4
2.2. IDENTIFYING THE MACHINE.....	5
2.3. DOCUMENTATION PROVIDED WITH THE MACHINE.....	5
3. TECHNICAL INFORMATION	5
3.1. GENERAL DESCRIPTION.....	5
3.2. LEGEND.....	5
3.3. DANGER ZONES.....	5
3.4. ACCESSORIES.....	6
4. SAFETY INFORMATION	6
4.1. SAFETY REGULATIONS.....	6
5. HANDLING AND INSTALLATION	9
5.1. LIFTING AND TRANSPORTING THE PACKAGED MACHINE.....	9
5.2. CHECKS ON DELIVERY.....	9
5.3. UNPACKING.....	9
5.4. BATTERIES.....	9
5.4.1. Batteries: preparation.....	10
5.4.2. Batteries: installation and connection.....	10
5.4.3. Batteries: removal.....	11
5.5. THE BATTERY CHARGER.....	12
5.5.1. Choosing the battery charger.....	12
5.5.2. Preparing the battery charger.....	12
5.6. LIFTING AND TRANSPORTING THE MACHINE.....	12
6. PRACTICAL GUIDE FOR THE OPERATOR	12
6.1. CONTROLS - DESCRIPTION.....	12
6.2. MOUNTING AND ADJUSTING THE SQUEEGEE.....	14
6.3. MOVING THE MACHINE WHEN NOT IN OPERATION.....	14
6.4. MOUNTING AND CHANGING THE BRUSH/DRIVE DISKS.....	14
6.5. DETERGENTS - INSTRUCTIONS.....	15
6.6. PREPARING THE MACHINE FOR WORK.....	15
6.7. WORKING.....	16
6.8. SOME USEFUL TIPS TO GET THE MOST FROM YOUR SCRUBBER DRIER.....	17
6.8.1. Prewashing with brushes or pads.....	17
6.8.2. Drying.....	17
6.9. DRAINING THE DIRTY WATER.....	17
6.10. DRAINING THE CLEAN WATER.....	18
7. PERIODS OF INACTIVITY	18
8. BATTERY MAINTENANCE AND CHARGING	18
8.1. CHARGING PROCEDURE.....	19
9. MAINTENANCE INSTRUCTIONS	19
9.1. MAINTENANCE - GENERAL RULES.....	19
9.2. ROUTINE MAINTENANCE.....	20
9.2.1. CT 160 basket filter: cleaning.....	20
9.2.2. CT 230 basket filter and float switch.....	20
9.2.3. CT 160 suction motor air filter: cleaning.....	20
9.2.4. CT 230 Suction motor air filter: cleaning.....	20
9.2.5. Detergent filter: cleaning.....	20
9.2.6. Squeegee blades: replacing.....	20
9.2.7. Fuses: replacement.....	21

9.3.	ROUTINE MAINTENANCE	22
9.3.1.	<i>Daily operations</i>	22
9.3.2.	<i>Weekly operations</i>	22
9.3.3.	<i>Six monthly operations</i>	22
10.	CONFIGURING THE SCRUBBER DRIER	23
11.	TROUBLESHOOTING	24

2. GENERAL INFORMATION



Read this manual carefully before carrying out any work on the machine¹

2.1. Scope of the manual

This manual has been written by the Manufacturer and is an integral part of the machine. It defines the purpose for which the machine has been designed and constructed and contains all the information required by operators².

In addition to this manual containing all user information, other publications are available providing specific information for maintenance personnel³.

Constant respect for the instructions guarantees the safety of the operator and the machine, low running costs and high quality results and extends the working life of the machine. Failure to respect the instructions may lead to damage to the operator, machine, floor being washed and environment.

To find the topic that interests you more rapidly, consult the list of contents at the beginning of the manual.

Parts of the text requiring special attention are highlighted in bold and preceded by the symbols illustrated and described here.

! DANGER

Indicates the need for attention in order to avoid a series of consequences which could cause death or damage to the health of the operator.

👉 IMPORTANT

Indicates the need for attention in order to avoid a series of consequences which could cause damage to the machine or work environment or financial loss.

i INFORMATION

Particularly important instructions.

In line with the company's policy of constant product development and updating, the Manufacturer reserves the right to make modifications without warning.

Although your machine may differ appreciably from the illustrations in this document, safety and the information contained in this manual are guaranteed.

¹ The definition "machine" replaces the trade name covered by this manual..

² Persons responsible for using the machine without performing any operations requiring precise technical skills.

³ Persons with experience, technical training and a knowledge of legislation and standards, able to perform all the necessary operations and to recognise and avoid possible risks in handling, installation, use and maintenance of this machine.

2.2. Identifying the machine

The rating plate provides the following information:

- model;
- power supply;
- total nominal power;
- serial number;
- year of fabrication;
- dry weight;
- maximum slope;
- barcode with serial number;
- manufacturer's identification.

2.3. Documentation provided with the machine

- User manual;
- guarantee certificate;
- EC certificate of conformity.

3. TECHNICAL INFORMATION

3.1. General description

This machine is a scrubber drier for sweeping, washing and drying flat, horizontal, smooth or moderately rough, even and obstacle free floors in civil and industrial premises.

The scrubber drier spreads a solution of water and detergent in the correct concentration on the floor and then scrubs it to remove the dirt. By carefully choosing the detergent and brushes (or abrasive disks) from the wide range of accessories available, the machine can be adapted to a wide range of combinations of types of floor and dirt.

A suction system incorporated in the machine dries the floor after washing by means of the low pressure generated in the dirty water tank by the suction motor. The squeegee connected to the tank collects the dirty water.

3.2. Legend

The main parts of the machine are as follows:

- detergent tank (fig. A, ref. 1): contains and transports the mixture of clean water and detergent;
- dirty water tank (fig. A, ref. 2): collects the dirty water picked up from the floor after washing;
- control panel (fig. A, ref. 3);
- head assembly (fig. A, ref. 4): the main element is the brushes which distribute the detergent solution on the floor and remove the dirt;
- squeegee assembly (fig. A, ref. 5): wipes and dries the floor by collecting the water;

3.3. Danger zones

A - **Tank assembly:** when using certain detergents, danger of irritation for eyes, skin, mucous membranes and respiratory tract and of asphyxia. Danger represented by the dirt collected from the environment (germs and chemical substances). Danger of crushing between the tank assembly and chassis.

! DANGER

The tank assembly (CT 230) MUST ALWAYS BE raised and lowered using the handles incorporated in the tank (fig. C, ref. 3).

! DANGER

When the tank assembly (CT230) is raised, the gas spring on the left side of the machine (fig. T) must be locked in place by turning the green ring to the closed padlock position to prevent the tanks from closing accidentally.

B -**Control panel** danger of short circuit.

C -**Bottom of washing head:** danger due to brush rotation.

D -**Rear wheels:** danger of crushing between the wheel and chassis.

E -**Battery compartment:** danger of short circuit between the battery poles and presence of hydrogen during charging.

F -**Side brushes:** danger due to brush rotation.

3.4. Accessories

- **Bristle brushes:** for washing delicate floors and polishing;
- **Polypropylene brushes:** for normal floor washing;
- **Tynex brushes:** for removing accumulated stubborn dirt on resistant floors;
- **Drive disks:** enable the following disks to be used:
 - * Yellow disks: for washing and polishing marble and similar surfaces;
 - * Green disks: for washing resistant floors;
 - * Black disks: for thorough washing of resistant floors with stubborn dirt.
- **CHEM DOSE (CT 230 only)** (fig. G): system for controlling detergent independently from the detergent tank.

4. SAFETY INFORMATION

4.1. Safety regulations



Read the "User Manual" carefully before start-up and use or before performing maintenance or any other work on the machine.

! IMPORTANT

Rigorously respect all instructions in the Manual (in particular those relating to danger and important information) and on the safety plates fitted to the machine. The Manufacturer declines all liability for damage to people or things resulting from failure to observe the instructions.

The appliance must be used exclusively by persons trained in its use and/or who have demonstrated their ability and have been expressly instructed to use the appliance.

The machine must not be used by minors.

The machine must not be used for purposes other than those for which it was expressly designed. Scrupulously respect all safety standards and conditions applicable to the type of building in which the machine is to be operated (e.g. pharmaceutical companies, hospitals, chemicals, etc).

Do not use the machine in places with inadequate lighting or explosive atmospheres, on public roads, in the presence of dirt hazardous to health (dust, gas, etc) and in unsuitable environments.

The machine is designed for temperatures of between +4°C and +35°C when in use and between +0°C and +50°C when not in use.

The machine is designed to work in a humidity of between 30% and 95%.

Never use or pick up flammable liquids or explosives (e.g. petrol, fuel oil, etc), flammable gases, dry dusts, acids and solvents (e.g. paint solvents, acetone etc) even if diluted. Never pick up flaming or incandescent objects.

Never use the machine on slopes or ramps of more than 16%. In the case of slight slopes, do not use the machine transversally, always manoeuvre with care and do not reverse. When transporting the machine on steeper ramps or slopes, take the utmost care to avoid tipping up and/or uncontrolled acceleration. Move the machine on ramps and/or steps only with the brush head and squeegee raised.

Never park the machine on a slope.

The machine must never be left unattended with the motors on. Before leaving it, turn the motors off and make sure it cannot move accidentally by putting the parking brake on and disconnecting it from the power supply.

Always pay attention to other people, children in particular, present in the place where you are working.

Children must be supervised to make sure they do not play with the appliance.

The appliance is not intended for use by persons (including children) with reduced physical, sensory or mental capabilities, or lack of experience and knowledge, unless they have been given supervision or instruction concerning use of the appliance by a person responsible for their safety.

Never use the machine to transport people or things or to tow things. Do not tow the machine.

Never rest objects of any weight on the machine for any reason.

Never obstruct ventilation and heat dispersion slits.

Never remove, modify or circumvent safety devices.

Numerous unpleasant experiences have shown that a wide range of personal objects may cause serious accidents. Before beginning work, remove jewellery, watches, ties, etc.

The operator must always use personal protection devices: protective apron or overalls, non-slip waterproof shoes, rubber gloves, protective goggles and ear protectors and mask to protect the respiratory tract.

Keep the hands away from moving parts.

Never use detergents other than those specified. Follow the instructions on the relative safety sheet. Detergents should be kept out of reach of children. In the event of contact with the eyes, wash immediately with abundant water. If swallowed, consult a doctor immediately.

Make sure the power sockets used for the battery charger are connected to a suitable earth system and protected by differential thermal solenoid switches.

Make sure the electrical characteristics of the machine (voltage, frequency, absorbed power) given on the rating plate are the same as those of the mains electricity supply.

It is indispensable to respect the battery manufacturer's instructions and current legislation. The batteries should always be kept clean and dry to avoid surface leakage current. Protect the batteries from impurities such as metal dust.

Never rest tools on the batteries as this could cause short circuit and explosion.

When using battery acid, always follow the relative safety instructions scrupulously.

Battery charger (**OPTIONAL**): check the power cable regularly for damage. If the power cable is damaged, the charger must not be used.

In the presence of particularly strong magnetic fields, assess the possible effect on the control electronics.

Never wash the machine with water jets.

The fluids collected contain detergent, disinfectant, water and organic and inorganic material. They must be disposed off in accordance with current legislation.

In the case of malfunction and/or faulty operation, turn the machine off immediately (disconnecting it from the mains power supply or batteries) and do not tamper. Contact a service centre authorised by the Manufacturer.

All maintenance operations must be performed in an adequately lit place and only after disconnecting the machine from the power supply.

! DANGER

When the tank assembly (CT230) is raised, the gas spring on the left side of the machine (fig. T) must be locked in place by turning the green ring to the closed padlock position to prevent the tanks from closing accidentally.

The tank assembly **MUST ALWAYS BE** lowered/raised using the handles incorporated in the tank (fig. C, ref. 3). Danger of crushing the limbs.

The tank assembly (CT 160 – CT 230) **MUST ALWAYS BE** lowered/raised with the tanks empty.

All work on the electrical system and all maintenance and repair operations other than those explicitly described in this manual must be performed by specialised personnel expert in the sector only.

Only original accessories and spare parts supplied by the Manufacturer may be used in order to guarantee safe problem-free operation of the machine. Never use parts removed from other machines or from other kits.

This machine has been designed and constructed to provide ten years' service from the fabrication date shown on the rating plate. After this time, whether the machine has been used or not, it should be disposed of according to current legislation in the country in which it is used:

- the machine must be disconnected from the power supply, emptied of liquids and cleaned;
- the product is classified as WEEE type special waste and is covered by the requisites of the new environmental protection regulations (2002/96/EC WEEE). It must be disposed of separately from ordinary waste in compliance with current legislation and standards.



Special waste. Do not dispose of with ordinary waste.

Alternatively the machine must be returned to the Manufacturer for a complete overhaul.

If you decide to stop using the machine, you are recommended to remove the batteries and dispose of them at an authorised collection centre.

You should also make sure that all parts of the appliance which could represent a hazard, particularly to children, are made safe.

5. HANDLING AND INSTALLATION

5.1. Lifting and transporting the packaged machine

IMPORTANT

**During all lifting operations, make sure the packaged machine is firmly anchored to avoid it tipping up or being accidentally dropped.
Always load/unload lorries in adequately lit areas.**

The machine, packaged on a wooden pallet by the Manufacturer, must be loaded using suitable equipment (see EC Directive 2006/42 and subsequent amendments and/or additions) onto the transporting vehicle. At destination, it must be unloaded using similar means.

The squeegees are packed in cardboard boxes without pallet.

A fork lift truck must always be used to lift the packaged body of the machine. Handle with care to avoid knocking or overturning the machine.

5.2. Checks on delivery

When the carrier delivers the machine, make sure the packaging and machine are both whole and undamaged. If the machine is damaged, make sure the carrier is aware of the damage and before accepting the goods, reserve the right (in writing) to request compensation for the damage.

5.3. Unpacking

IMPORTANT

When unpacking the machine, the operator must be provided with the necessary personal protection devices (gloves, goggles, etc) to limit the risk of accident.

Unpack the machine as follows:

- cut and remove the plastic straps using scissors or nippers;
- remove the cardboard;
- remove the bags in the battery compartment and check the contents:
 - use and maintenance manual, declaration of conformity, guarantee certificate;
 - battery bridges with terminals
 - connector for battery charger;
- depending on the model, remove the metal brackets or cut the plastic straps fixing the machine chassis to the pallet;
- using a sloping ramp, push the machine backwards off the pallet;
- unpack the brushes and squeegee;
- clean the outside of the machine in respect of safety regulations;
- once the machine is clear of the packaging, the batteries can be installed (see relevant paragraph).

The packaging may be kept as it can be reused to protect the machine if it is moved to another site or to a repair workshop.

Otherwise it must be disposed off in compliance with current legislation.

5.4. Batteries

Two different types of battery may be installed on these machines:

- **tubular leak-proof batteries:** the electrolyte level must be checked regularly. When necessary, top up with distilled water until the plates are covered. Do not overfill (5 mm max. above the plates).
- **gel batteries:** this type of battery requires no maintenance.

The technical characteristics must correspond to those indicated in the paragraph on the technical specification of the machine. The use of heavier batteries could seriously jeopardise manoeuvrability and lead to the brush motor overheating. Batteries with a lower capacity and weight will require charging more frequently. They must be kept charged, dry and clean and the connections must be tight.

i INFORMATION

Follow the instructions below to set the machine's software for the type of battery installed:

1. with the machine off, hold the buttons P1 (fig. B, ref. 1) and P3 (fig. B, ref. 2) down simultaneously and then start the machine by turning the ignition key (fig. B, ref. 3) to "1".
2. press the settings button (fig. B, ref. 4) 3 times.
3. press the "flow regulation" buttons (fig. B, ref. 5) to select the type of battery installed on the machine "ACd" for acid battery (tubular leak-proof batteries) or "GEL" (GEL batteries).
4. memorise the parameter displayed by holding the settings button (fig. B, ref. 4) down until the battery voltage is displayed.

5.4.1. Batteries: preparation

! DANGER

While installing or performing maintenance on the batteries, the operator must be provided with the necessary personal protection devices (gloves, goggles, overalls, etc) to limit the risk of accident. Keep away from naked flames, avoid short circuiting the battery poles, avoid sparks and do not smoke.

The batteries are normally supplied filled with acid and ready for use.

If the batteries are dry, before mounting them on the machine, proceed as follows:

- remove the caps and fill all elements with specific sulphuric acid solution until the plates are entirely covered (this requires at least a couple of passes for each element);
- leave for 4-5 hours to allow the air bubbles to come to the surface and the plates to absorb the electrolyte;
- make sure the level of electrolyte is still above the plates and if necessary top up with sulphuric acid solution;
- close the caps;
- mount the batteries on the machine (following the procedure described below).

Before starting up the machine for the first time, charge the batteries as follows.

5.4.2. Batteries: installation and connection

! DANGER

Check that all switches on the control panel are in the "0" (off) position. Make sure you connect the terminals marked with a "+" to the positive poles of the battery. Do not check the battery charge by sparking. Follow the instructions given below meticulously as shortcircuiting the batteries could cause them to explode.

CT160

- Make sure the dirty water tank is empty and empty it if necessary (see relevant paragraph).
- Lift the dirty water tank (fig. C, ref. 5) and tilt it backwards to access the battery compartment (fig. C, ref. 2) from the top, Rotate the seat cowling (fig. C, ref. 4) forwards.

CT230

- Make sure the two tanks are empty (if necessary, empty them, see relevant section), then unscrew the safety knob (fig. C, ref. 1).
- Lift the tank assembly and rotate it inwards, providing access to the battery compartment from the top (fig. C, ref. 2).

! DANGER

The tank assembly (CT 230) **MUST ALWAYS BE** raised using the handles incorporated in the tank (fig. C, ref. 3). Danger of crushing the limbs.

! DANGER

When the tank assembly (CT230) is raised, the gas spring on the left side of the machine (fig. T) must be locked in place by turning the green ring to the closed padlock position to prevent the tanks from closing accidentally.

- Place the batteries in the battery compartment in the direction shown in the diagram on the compartment.

👉 IMPORTANT

Mount the batteries on the machine using lifting means suitable for their weight. The positive and negative poles have different diameters.

- Referring to the wiring layout shown in the above diagram, connect the battery cable and bridge terminals to the battery poles. Arrange the cables as shown in the diagram, tighten the terminals on the poles and cover with Vaseline.
- Lower the tank assembly into the working position

! DANGER

The tank assembly (CT 230) **MUST ALWAYS BE** lowered using the handles incorporated in the tank (fig. C, ref. 3). Danger of crushing the limbs.

! DANGER

When the tank assembly (CT230) is raised, the gas spring on the left side of the machine (fig. T) must be locked in place by turning the green ring to the closed padlock position to prevent the tanks from closing accidentally.

- When using the machine, follow the instructions below.

5.4.3. Batteries: removal

! DANGER

When removing the batteries, the operator must be equipped with suitable personal protection devices (gloves, goggles, overalls, safety shoes, etc) to reduce the risk of accidents. Make sure the switches on the control panel are in the "0" position (off) and the machine is turned off. Keep away from naked flames, do not short circuit the battery poles, do not cause sparks and do not smoke. Proceed as follows:

- disconnect the battery wiring and bridge terminals from the battery poles.
- if necessary, remove the devices fixing the battery to the base of the machine.
- lift the batteries from the compartment using suitable lifting equipment.

5.5. The battery charger

IMPORTANT

Never allow the batteries to become excessively flat as this could damage them irreparably.

5.5.1. *Choosing the battery charger*

Make sure the battery charger is compatible with the batteries to be charged:

- **tubular lead batteries:** you are recommended to use an automatic battery charger. Consult the battery charger manufacturer and manual to confirm the choice.
- **gel batteries:** use a charger specific for this type of battery.

5.5.2. *Preparing the battery charger*

If you wish to use a battery charger not provided with the machine, you must fit it with the connector supplied with the machine (see paragraph "Unpacking" in this manual).

To install the connector, proceed as follows:

- remove about 13 mm of protective sheath from the red and black wires of the battery charger;
- insert the wires into the connector contacts and squeeze them forcefully with suitable pliers;
- respect the polarity (red wire + black wire –) when inserting the wires into the connector.

5.6. Lifting and transporting the machine

IMPORTANT

All phases must be performed in an adequately lit room and adopting the safety measures most appropriate to the situation.

The operator must always use personal protection devices.

To load the machine onto a means of transport, proceed as follows:

- empty the dirty water tank and detergent tank;
- remove the squeegee and brushes (or drive disks);
- remove the batteries;
- place the machine on the pallet and fix it with plastic straps or metal brackets;
- lift the pallet (with the machine) using a fork lift truck and load it onto the means of transport;
- anchor the machine to the means of transport with cables connected to the pallet and machine itself.

6. PRACTICAL GUIDE FOR THE OPERATOR

6.1. Controls - Description

With reference to fig. B, the machine has the following controls and indicator lights:

- **Display** (fig. B, ref. 6): displays alarms and menus. During normal operation, the hour counter (giving the actual number of hours the machine has been operating) and battery voltage are displayed.
- **Main Switch** (fig. B, ref. 3): enables and disables electrical power to all machine functions. To start up the machine, turn the key clockwise.
- **Emergency button** (fig. B, ref. 7): this acts as a safety device. To stop the machine press the button.

- **Brush button (MANUAL OPERATION)** (fig. B, ref. 8): enables (LED on) and disables (LED off) brush operation and head raising and lowering.
- **Suction button (MANUAL OPERATION)** (fig. B, ref. 9): starts and stops the suction motor responsible for drying the floor being washed. When the suction motor is turned on, the squeegee is automatically lowered. When it is turned off, the squeegee is automatically raised.
- **Detergent flow regulation buttons** (fig. B, ref. 5): pressing these buttons regulates the quantity of detergent delivered (displayed by LEDs).
- **Detergent tank level indicator** (fig. B, ref. 10): the LED comes on when there is no longer sufficient water in the detergent tank.
- **Dirty water tank level indicator** (fig. B, ref. 11): when the dirty water tank is full the LED comes on and after a few seconds the suction motor shuts down.
- **Direction selector** (fig. B, ref. 12): move this selector to set movement of the machine to forwards or reverse
- **Alarm indicator** (fig. B, ref. 13), the frequency with which the LED lights up defines the electronic board error code (see chapter 11). During operation in the absence of malfunction, the LED is on steadily.
- **Horn** (fig. B, ref. 14): acoustic warning.
- **Settings button** (fig. B, ref. 4): when pressed, scrolls through the various parameters which can be set on the machine software.
- **Work programme buttons (AUTOMATIC OPERATION)**: set the work programme to be used.
 1. **P1** (fig. B, ref. 1) light wash programme for smooth not excessively dirty floors.
 2. **P2** (fig. B, ref. 15) medium wash programme for smooth floors with evident dirt.
 3. **P3** (fig. B, ref. 2) heavy wash programme for rough floors (concrete etc.) with stubborn dirt.

Please note: before setting a new work programme, the previous programme must be deselected.

- **Brush attachment/release button** (fig. B, ref. 16): enables automatic brush attachment or release
- **CHEM DOSE switch (optional)** (fig. B, ref. 17): enables and disables CHEM DOSE operation
- **Service brake/parking brake** (fig. D, ref. 1), acts mechanically on the two drum brakes on the rear wheels.
- **Machine movement pedal** (fig. D, ref. 2): pivoting device to regulate machine speed.
- **Side brush lifting levers** (fig R, ref. 1): raising or lowering these levers disables or enables operation of the side brushes (when present).
- **Speed potentiometer** (fig. B, ref. 18): regulates the speed of the machine forwards and backwards.

i INFORMATION

The machine (CT 230 only) has a safety system to prevent it tipping over. This reduces the speed on bends, irrespective of the pressure exerted on the machine movement pedal. This reduction of speed on bends is therefore not a malfunction, but a feature which increases the machine's stability in all conditions.

6.2. Mounting and adjusting the squeegee

The squeegee (fig. E) is responsible for the first phase of drying.

To mount the squeegee on the machine, proceed as follows:

- make sure the squeegee mount (fig. E, ref. 1) is raised;
- insert the sleeve of the suction hose (fig. E, ref. 2) fully into the squeegee;
- slacken the two knobs (fig. E, ref. 3) at the centre of the squeegee;
- insert the two threaded pins into the slots on the support;
- fix the squeegee by tightening the two knobs (fig. E, ref. 3).
- The squeegee blades scrape the film of water and detergent from the floor and prepare the way for perfect drying. With time, the constant rubbing makes the edge of the blade in contact with the floor rounded and cracked, reducing the drying efficiency and requiring it to be replaced. The state of wear should be checked frequently.
- For perfect drying, the squeegee must be adjusted in such a way that the edge of the rear blade bends during operation by about 45° with respect to the floor at every point. The angle of the blades can be adjusted during work by turning the knob (fig. E, ref. 5) on the squeegee mount. The height of the squeegee can be adjusted by adjusting the height of the wheels on the squeegee mount (fig. E, ref. 4).

6.3. Moving the machine when not in operation

To move the machine, proceed as follows:

- raise the squeegee;
- raise the head;
- use the selector (fig. B, ref. 12) to set the direction of movement;
- operate the accelerator pedal (fig. D, ref. 2).

IMPORTANT

Do not leave the machine unattended or parked with the key inserted in the main switch and the parking brake off.

6.4. Mounting and changing the brush/drive disks

IMPORTANT

Never work without the brushes and drive disks correctly installed.

Automatic brush attachment: with the head raised and the machine off, lift the side flaps on both sides (fig. F, ref. 1) and place the brushes under the head, making sure they rest against the centring devices to align them with the attachment assembly. Start the machine by turning the main switch and press the brush attachment/release button (fig. B, ref. 16). The machine first performs a release operation (LED flashing), then immediately afterwards enables the attachment operation (LED flashing). The machine is now ready for attachment of the brushes, performed by pressing the brush attachment/release button (fig. B, ref. 16) again. When the button is pressed, the LED flashes until the attachment operation is complete.

Automatic brush release:

stop brush rotation and turn the suction motor off, then press the brush attachment/release button (fig. B, ref. 16). The machine performs the release operation (LED flashing).

Attaching the brushes on a roller head: with the head raised and the machine off, open the side flap plate (fig. S, ref. 1) by unhooking the spring (fig. S, ref. 2). Remove the brush compartment cover (fig. S, ref. 3) by pulling the release lever (fig. S, ref. 4), then insert the brushes in the two compartments, making sure you intercept the guide pin on the opposite side correctly. Replace the cover and close the side flap plate.

Releasing the brushes on a roller head: repeat the above procedure in reverse.

Attaching the side brushes (when present): to facilitate transport, the side brushes are not installed in the operating position. To install the side brushes, proceed as follows:

- Unscrew the screws on the side brush motor shaft.
- Make sure the cotter pin is inserted on the motor shaft.
- Insert the brush complete with flange on the motor shaft.
- Screw the locking screw up again.

Releasing the side brushes: repeat the above procedure in reverse.

6.5. Detergents - Instructions

IMPORTANT

Always dilute the detergent according to the manufacturer's instructions. Do not use sodium hypochlorite (bleach) or other oxidants, particularly in strong concentrations. Do not use solvents or hydrocarbons. The temperature of the water and detergent must not exceed the maximum indicated in the technical specification. They must be free of sand and/or other impurities.

The machine has been designed for use with low-foam biodegradable detergents made specifically for scrubber driers.

For a complete and up-to-date list of the detergents and chemicals available, contact the Manufacturer.

Use products suitable for the floor and dirt to be removed only.

Follow the safety regulations on use of detergents given in the section "Safety regulations".

6.6. Preparing the machine for work

IMPORTANT

Before starting work, wear overalls, ear protectors, non-slip waterproof shoes, mask to protect the respiratory tract, gloves and all other personal protection devices recommended by the supplier of the detergent used or necessitated by the work environment.

Before starting work, proceed as follows:

- check the battery charge (charge if necessary);
- make sure the dirty water tank (fig. A, ref. 2) is empty. If necessary, empty it;
- via the opening, fill the detergent tank (fig. A, ref. 1) with a suitable concentration of clean water and low-foam detergent. Leave at least 5 cm between the surface of the liquid and the opening of the tank;
- if the machine is fitted with the optional CHEM DOSE accessory, fill the CHEM DOSE tank (fig. G, ref. 2) with appropriately diluted low-foam detergent.
- mount the most suitable brushes or drive disks for the floor and work to be performed (see paragraph 3.4);
- make sure the squeegee (fig. E) is firmly attached and connected to the suction hose (fig. E, ref. 2). Make sure the back blade is not worn.

i INFORMATION

If you are using the machine for the first time, we recommend trying it on a large obstacle-free surface first to acquire the necessary familiarity.

Always empty the dirty water tank before filling the detergent tank again.

For effective cleaning and to extend the working life of the machine, follow a few simple rules:

- prepare the work area by removing all possible obstacles;
- begin working from the furthestmost point to avoid walking on the area you have just cleaned;
- choose the straightest possible working routes;
- divide large floors into parallel rectangular sections.

If necessary, finish off by passing a mop or rag rapidly over parts inaccessible to the scrubber drier.

6.7. Working

i INFORMATION

The seat (fig. D, ref. 3) has a safety sensor which allows the machine to move only when the operator is seated.

i INFORMATION

The machine (CT 230 only) has a safety system to prevent it tipping over. This reduces the speed on bends, irrespective of the pressure exerted on the machine movement pedal. This reduction of speed on bends is therefore not a malfunction, but a feature which increases the machine's stability in all conditions.

i INFORMATION

When the machine movement pedal is released, all functions shut down automatically within 5 seconds (Auto Power-Off). While the machine is in stand-by, the light corresponding to the set programme will flash. To reactivate the functions, just move the machine without deselecting the set programme (Auto Power-On).

After setting up the machine, proceed as follows:

- start the machine by turning the key (main switch) clockwise (fig. B, ref. 3).
- Select the most suitable programme from the three available. Pressing one of the work programme buttons activates all the functions of the chosen programme (brush motors and suction motor on).
 - **P1** (fig. B, ref. 1) light wash programme for smooth not excessively dirty floors.
 - **P2** (fig. B, ref. 15) medium wash programme for smooth floors with evident dirt.
 - **P3** (fig. B, ref. 2) heavy wash programme for rough floors (concrete etc.) with stubborn dirt.
- Press the detergent flow regulation buttons (fig. B, ref. 5): to set the quantity of detergent delivered (displayed by LEDs).
- use the direction selector (fig. B, ref. 12) to set the direction of movement;
- press the machine movement pedal (fig. D, ref. 2).
- the maximum working speed can be set by turning the speed potentiometer (fig. B, ref. 18).
- If the machine is fitted with side brushes, these must be lowered using the levers on the steering column. The brush motors will not start unless the brushes are fully lowered (fig. R, ref. 1).
- Begin working.
- If the machine is fitted with the optional CHEM DOSE accessory, press the button (fig. B, ref. 17) to turn the device on, then adjust the detergent mixture to send to the

brushes using the regulation screw (fig. G, ref. 1). The quantity can be adjusted from 0.5% to 3% per litre of water.

IMPORTANT

Empty the dirty water tank each time you fill the detergent tank.

- when the dirty water tank is full, the corresponding level indicator comes on (fig. B, ref. 11) and after a few seconds the suction motor shuts down. You must stop working and empty the tank.
- when the detergent tank is empty, the corresponding level indicator comes on (fig. B, ref. 10), the machine emits an intermittent beep and "water reserve" is displayed. You must stop work and fill the detergent tank.
- The machine has a safety device which automatically disables all functions, apart from the drive, when the batteries drop below about 29 V. You must charge the batteries.

At the end of work:

- Disable the chosen wash programme (fig. B, ref. 1,2,15 (LED off));
- release the machine movement pedal (fig. D, ref. 2)
- turn the optional CHEM DOSE accessory off (fig. B, ref. 17);
- put the parking brake (fig. D, ref. 1) on;
- stop the machine by turning the key (main switch) anticlockwise (fig. B, ref. 3).
- disconnect the batteries;
- empty and clean the dirty water tank using the drain hose (fig. H, ref. 1).
- empty and clean the debris bin, ROLLER head version (fig. S, ref 5).

6.8. Some useful tips to get the most from your scrubber drier

In the event of particularly stubborn dirt on the floor, washing and drying can be performed in two separate operations.

6.8.1. Prewashing with brushes or pads

- start the machine by turning the key (main switch) clockwise (fig. B, ref. 3).
- adjust the detergent flow (fig. B, ref. 5);
- press the brush button (fig. B, ref. 8) (LED on);
- stop the suction motor by pressing the button (fig. B, ref. 9) (LED off);
- If the machine is fitted with the optional CHEM DOSE accessory, press the button (fig. B, ref. 17) to turn the device on, then adjust the detergent mixture to send to the brushes using the regulation screw (fig. G, ref. 1). The quantity can be adjusted from 0.5% to 3% per litre of water.
- begin washing.

The flow of water must be adjusted in proportion to the desired advance speed. The slower the machine moves forwards, the less water is needed.

Persist when washing particularly dirty points to give the detergent time to perform its chemical action detaching and suspending the dirt and the brushes time to exert an effective mechanical action.

6.8.2. Drying

Turn the suction motor on by pressing the button (fig. B, ref. 9), then pass over the same area washed previously. The result is equivalent to in-depth washing and subsequent ordinary maintenance will take less time.

6.9. Draining the dirty water

! DANGER

Use suitable personal protection devices.

The dirty water tank drain hose is at the back of the machine on the right.

To empty the tank:

- move the machine near a drain;
- remove the drain hose (fig. H, ref. 1) from its housing;
- keeping the end of the hose as high as possible, unscrew and remove the cap;
- lower the end of the hose gradually, controlling the intensity of the flow of water by adjusting the height from the ground;
- check the amount of dirt left in the dirty water tank and if necessary wash it out;
- close the drain hose (fig. H, ref. 1) by replacing the cap, check that it is tightly closed and replace the hose in its housing.

You are then ready to wash and dry again.

6.10. Draining the clean water

! DANGER

Use suitable personal protection devices.

To empty the tank:

- move the machine near a drain;
- remove the drain hose (fig. H, ref. 2) from its housing;
- keeping the end of the hose as high as possible, unscrew and remove the cap;
- lower the end of the hose gradually, controlling the intensity of the flow of water by adjusting the height from the ground;
- when the detergent tank is empty, close the drain hose (fig. H, ref. 2) by replacing the cap, check that it is tightly closed and replace the hose in its housing.

i INFORMATION

The water and detergent solution can also be used to wash the dirty water tank.

7. PERIODS OF INACTIVITY

If the machine is not used for some time, remove the squeegee, brushes and drive disks, wash them and put them away in a dry place (preferably in a bag or wrapped in plastic film) away from dust. Park the machine with the parking brake on.

Make sure the tanks are completely empty and perfectly clean.

Disconnect the machine from the power supply.

Charge the batteries completely before storing them. During long periods of inactivity, you should charge the batteries regularly (at least once every two months) to keep them constantly at maximum charge.

👉 IMPORTANT

If you do not charge the batteries regularly, they may be irrevocably damaged.

8. BATTERY MAINTENANCE AND CHARGING

! DANGER

**Do not check the batteries by sparking.
The batteries give off flammable fumes. Put out all fires and hot embers before
checking or topping up the batteries.**

Perform the operations described above in a ventilated room.

To avoid permanent damage to the batteries, do not run them down completely.
Remember that when the battery voltage displayed drops to about 29V, the batteries
must be charged.

8.1. Charging procedure

- connect the battery charger connector to the battery wiring connector;

! IMPORTANT

In the case of gel batteries, use a charger specific for gel batteries only.

- Charge the batteries as described in the battery charger manual;
- at the end of charging, disconnect the connectors;

9. MAINTENANCE INSTRUCTIONS

! DANGER

**Never perform any maintenance operations without first disconnecting the
batteries.**

**Maintenance on the electrical circuit and all other operations not explicitly
described in this manual must be performed by specialised personnel only, in
compliance with current safety legislation and as described in the maintenance
manual.**

! DANGER

**The tank assembly (CT 230) MUST ALWAYS BE lowered/raised using the handles
incorporated in the tank (fig. C, ref. 3). Danger of crushing the limbs.**

! DANGER

**When the tank assembly (CT230) is raised, the gas spring on the left side of the
machine (fig. T) must be locked in place by turning the green ring to the closed
padlock position to prevent the tanks from closing accidentally.**

! DANGER

**The tank assembly (CT 160 – CT 230) MUST ALWAYS BE lowered/raised with the
tanks empty.**

! DANGER

**When the tank assembly (CT230) is raised, the gas spring on the left side of the
machine (fig. T) must be locked in place by turning the green ring to the closed
padlock position to prevent the tanks from closing accidentally.**

9.1. Maintenance - General rules

Performing regular maintenance according to the Manufacturer's instructions improves
performance and extends the working life of the machine.

When cleaning the machine, respect the following:

- avoid the use of high pressure washers. Water could penetrate the electrical compartment or motors leading to damage or the risk of short circuit;
- do not use steam to avoid the heat warping plastic parts;
- do not use hydrocarbons or solvents as they could damage the cowling and rubber parts.

9.2. Routine maintenance

9.2.1 CT 160 basket filter: cleaning

- remove the basket filter from the water fill hole (fig. I, ref. 5);
- clean the filter with running water or the detergent solution used on the machine;
- replace the filter, making sure it is correctly positioned in its housing.
- put the cap back.

9.2.2 CT 230 basket filter and float switch

- access the dirty water tank by turning the lid (fig. I, ref. 1);
- make sure the dirty water tank is empty;
- remove the float switch guard (fig. I, ref. 2).
- clean the float switch (fig. I, ref. 3) at the front of the dirty water tank, taking care not to direct the water jet directly against the float switch;
- remove the basket filter from the water fill hole (fig. I, ref. 4);
- clean the filter with running water or the detergent solution used on the machine;
- replace the filter, making sure it is correctly positioned in its housing.
- close the dirty water tank lid (fig. I, ref. 1).

9.2.3 CT 160 suction motor air filter: cleaning

- rotate the seat cowling (fig. L, ref. 3) forwards, lift the suction motor assembly cover (fig. L, ref. 4) and remove the filter (fig. L, ref. 5);
- clean the filter with running water or the detergent solution used on the machine;
- dry the filter thoroughly, then replace in its housing;
- close the seat cowling (fig. L, ref. 3).

9.2.4 CT 230 Suction motor air filter: cleaning

- lift the suction motor assembly cover (fig. L, ref. 1) and remove the filter (fig. L, ref. 2);
- clean the filter with running water or the detergent solution used on the machine;
- dry the filter thoroughly, then replace in its housing;
- replace the suction motor assembly cover (fig. L, ref. 1).

9.2.5 Detergent filter: cleaning

- unscrew the cover above the filter assembly (fig. M, ref. 1);
- remove the filter;
- clean the filter with running water or the detergent solution used on the machine;
- replace the filter in its housing and screw the cover back on the filter assembly.

9.2.6 Squeegee blades: replacing

The squeegee blades collect the film of water and detergent from the floor and prepare the way for perfect drying. With time, the constant rubbing leaves the edge of the blade

in contact with the floor rounded and cracked, reducing the drying efficiency and requiring it to be replaced.

CT 160 Turning or replacing the rear blade:

- remove the squeegee from its mount by unscrewing the two knobs (fig. N, ref. 1);
- remove the suction hose sleeve from the squeegee;
- unscrew the nuts (fig. N, ref. 2);
- release the clip (fig. N, ref. 3);
- extract the two blade retainers (fig. N, ref. 4);
- remove the blade (fig. N, ref. 5);
- reuse the same blade by reversing the edge in contact with the floor until all four edges are worn out, or replace with a new blade, fitting it onto the screws on the body of the squeegee;
- replace the two blade retainers (fig. N, ref. 4) and screw up the nuts (fig. N, ref. 2)
- refasten the clip (fig. N, ref. 3).

Replace the squeegee in its support following the instructions in paragraph 6.2.

CT 160 Turning or replacing the front blade:

- remove the squeegee from its mount by unscrewing the two knobs (fig. O, ref. 1);
- remove the suction hose sleeve from the squeegee;
- unscrew the nuts (fig. O, ref. 2);
- extract the two blade retainers (fig. O, ref. 3);
- remove the blade (fig. O, ref. 4);
- reuse the same blade by reversing the edge in contact with the floor until both edges are worn out, or replace with a new blade, fitting it onto the screws on the body of the squeegee;
- replace the two blade retainers (fig. O, ref. 3) and screw up the nuts (fig. O, ref. 2).

Replace the squeegee in its support following the instructions in paragraph 6.2.

CT 230 Turning or replacing the front and rear blade:

- remove the squeegee from its mount by unscrewing the two knobs (fig. P, ref. 1);
- remove the suction hose sleeve from the squeegee;
- unscrew the nuts (fig. P, ref. 2);
- extract the two blade retainers (fig. P, ref. 3);
- remove the blades (fig. P, ref. 5-6)
- reuse the same blade by reversing the edge in contact with the floor until both edges are worn out, or replace with a new blade, fitting it onto the screws on the body of the squeegee;
- replace the two blade retainers (fig. P, ref. 3) and screw up the nuts (fig. P, ref. 2).

Replace the squeegee in its support following the instructions in paragraph 6.2.

9.2.7 Fuses: replacement

The fuses protecting the electrical and electronic components are at the front of the machine under the front guard (fig. Q, ref. 1) and near the battery compartment (fig. Q, ref. 2).

To replace the fuses:

- make sure the machine is disconnected from the batteries;
- lift the fuse holder lid and remove the blown fuse;
- fit a new fuse and close the fuse holder cover.

Fuse table: for the complete fuse table, see the spare parts catalogue.

IMPORTANT

Never use a fuse with a higher amperage than specified.

If a fuse continues to blow, the fault in the wiring, boards (if present) or motors must be identified and repaired. Have the machine checked by qualified personnel.

9.3. Routine maintenance

9.3.1. Daily operations

After each day's work, proceed as follows:

- disconnect the machine from the power supply;
- empty the dirty water tank and clean if necessary;
- clean the squeegee blades and check for wear. If necessary, replace;
- check that the suction hole in the squeegee is not blocked, if necessary remove encrusted dirt;
- charge the batteries according to the procedure described;
- empty and clean the debris bin, ROLLER head version (fig. S, ref 5).

9.3.2. Weekly operations

- clean the dirty water tank float switch and make sure it is working correctly;
- clean the suction air filter and make sure it is undamaged, if necessary, replace;
- clean the detergent filter (fig. M, ref. 1) and check that it is not damaged (replace if necessary);
- clean the suction hose;
- clean the dirty water tank and detergent tank;
- check the level of battery electrolyte and top up with distilled water if necessary;
- check operation of the service brake.

9.3.3. Six monthly operations

Have the electrical circuit checked by qualified personnel.

10. CONFIGURING THE SCRUBBER DRIER

To change the default settings, proceed as follows.

With the machine on but no function active, press the settings button (fig. B, ref. 4) for at least 5 seconds. You can now vary the parameters below in the following order:

1. **LANGUAGE:** select using the "+" and "-" buttons (fig. B, ref. 5). Press the settings button (fig. B, ref. 4) to save the setting then move on to the next parameter.
2. **PROGRAMME 1 BRUSH PRESSURE FROM 010 TO 100:** change using the "+" and "-" buttons (fig. B, ref. 5). Press the settings button (fig. B, ref. 4) to save the setting then move on to the next parameter. **DEFAULT = 030**
3. **PROGRAMME 1 BRUSH ENABLING ON-OFF** change using the "+" and "-" buttons (fig. B, ref. 5). Press the settings button (fig. B, ref. 4) to save the setting then move on to the next parameter. **DEFAULT = ON**
4. **PROGRAMME 1 SUCTION MOTOR ENABLING ON-OFF** change using the "+" and "-" buttons (fig. B, ref. 5). Press the settings button (fig. B, ref. 4) to save the setting then move on to the next parameter. **DEFAULT = ON**
5. **PROGRAMME 1 WATER DELIVERY:** change using the "+" and "-" buttons (fig. B, ref. 5). The following values can be set:
OFF, when the programme is run, water delivery is not active
Lev. 1, pump active at 18% of working cycle
Lev. 2, pump active at 36% of working cycle
Lev. 3, pump active at 45% of working cycle
Lev. 4, pump active at 60% of working cycle
Lev. 5, pump active at 75% of working cycle
Lev. 6, pump active at 100% of working cycle
AUTO, pump active in proportion to working cycle of drive
Up to 16% speed, pump 18% active
Up to 32% speed, pump 36% active
Up to 50% speed, pump 45% active
Up to 65% speed, pump 60% active
Up to 80% speed, pump 75% active
More than 80% speed, pump 100% active
Press the settings button (fig. B, ref. 4) to save the setting then move on to the next parameter.
DEFAULT = 2
6. **PROGRAMME 1 SPEED:** maximum drive speed. The parameter can be varied from 010 to 100. It can be changed using the "+" and "-" buttons (fig. B, ref. 5). Press the settings button (fig. B, ref. 4) to save the setting then move on to the next parameter. **DEFAULT = 100**
7. **PROGRAMME 1 POWER ENABLING ON-OFF:** change using the "+" and "-" buttons (fig. B, ref. 5) Press the settings button (fig. B, ref. 4) to save the setting then move on to the next parameter. **DEFAULT = ON**

For PROGRAMMES 2 and 3, use the above procedure. To exit the settings menu, hold the settings button (fig. B, ref. 4) down until battery voltage is displayed.

11. TROUBLESHOOTING

11.1. How to resolve possible problems

Possible problems affecting the whole machine.

PROBLEM	CAUSE	REMEDY
The machine does not function	• battery connector disconnected	• connect the batteries to the machine
	• the batteries are flat	• charge the batteries
The brushes do not turn	• brush switch not pressed	• press the brush switch
	• the accelerator has not been operated	• operate the accelerator
	• the batteries are flat	• charge the batteries
	• the reduction unit is faulty	• have the reduction unit replaced
	• the motor is faulty	• have the motor replaced
The side brushes do not turn	• the brushes are raised	• lower the side brushes using the lever on the steering column
	• the fuse has tripped	• reset the fuse by pressing the button on the fuse itself
	• the reduction unit is faulty	• have the reduction unit replaced
	• the motor is faulty	• have the motor replaced
The machine does not clean evenly	• the brush or disks are worn	• replace
No detergent is delivered	• the detergent tank is empty	• fill it
	• the hose delivering the detergent to the brush is blocked	• unblock and open the circuit
	• the solenoid valve is faulty	• replace the solenoid valve
	• pump malfunction	• replace the pump.
	• the filter is clogged	• clean the filter
The detergent flow does not stop	• the solenoid valve is faulty	• replace the solenoid valve
The suction motor does not start	• the suction button has not been pressed (off)	• press the suction button.
	• there is no power to the suction motor or the motor is faulty	• check that the motor power connector is correctly connected to the main wiring; if it is correctly connected, have the motor replaced
	• dirty water tank full	• empty the dirty water tank.
The squeegee does not clean or suction is ineffective	• the edge of the rubber blades in contact with the floor is worn	• replace the rubber blade
	• the squeegee or hose is blocked or damaged	• unblock and repair the damage

	<ul style="list-style-type: none"> • the float switch has tripped (dirty water tank), is clogged by dirt or broken 	<ul style="list-style-type: none"> • empty the dirty water tank or reset the float switch
	<ul style="list-style-type: none"> • the suction hose is blocked 	<ul style="list-style-type: none"> • unblock the hose
	<ul style="list-style-type: none"> • the suction hose is not connected to the squeegee or is damaged 	<ul style="list-style-type: none"> • connect or repair the hose
	<ul style="list-style-type: none"> • there is no power to the suction motor or the motor is faulty 	<ul style="list-style-type: none"> • check that the motor power connector is correctly connected to the main wiring and that the fuse is not blown; in the second case have the motor replaced

The machine does not move	<ul style="list-style-type: none"> • the suction motor does not operate 	<ul style="list-style-type: none"> • release the emergency button; make sure the motor is connected correctly to the main wiring; check the type of alarm present on the board (see chapter 11); replace the motor.
	<ul style="list-style-type: none"> • the motor thermal cutout has tripped; the motor has overheated 	<ul style="list-style-type: none"> • stop the machine, turn it off and leave it to cool for at least 45'
	<ul style="list-style-type: none"> • the batteries are flat 	<ul style="list-style-type: none"> • charge the batteries

The batteries do not provide the normal work time	<ul style="list-style-type: none"> • the battery poles and charging terminals are dirty and oxidised 	<ul style="list-style-type: none"> • clean and grease the poles and terminals, charge the batteries
	<ul style="list-style-type: none"> • the electrolyte level is low 	<ul style="list-style-type: none"> • top up all the elements with distilled water as described in the instructions
	<ul style="list-style-type: none"> • the battery charger does not work or is unsuitable 	<ul style="list-style-type: none"> • see battery charger instructions
	<ul style="list-style-type: none"> • there are considerable differences in density between the various elements of the battery 	<ul style="list-style-type: none"> • replace the damaged battery
	<ul style="list-style-type: none"> • you are using the machine with excessive pressure on the brushes 	<ul style="list-style-type: none"> • reduce pressure on the brush

The battery discharges too fast during use, even though it has been charged correctly and when tested with a hydrometer at the end of charging, it turned out to be uniformly charged	<ul style="list-style-type: none"> • the battery is new and does not deliver 100% of its expected capacity 	<ul style="list-style-type: none"> • the battery must be "run-in" by performing 20-30 charges and discharges to obtain maximum performance
	<ul style="list-style-type: none"> • the machine is being used at maximum capacity for continuous periods and the working time is not sufficient 	<ul style="list-style-type: none"> • if possible, use batteries with a higher capacity or replace the batteries with others charged previously
	<ul style="list-style-type: none"> • the electrolyte has evaporated and does not cover the plates completely 	<ul style="list-style-type: none"> • top up all elements with distilled water until the plates are covered then charge the battery

The electrolyte in the battery is turbid	<ul style="list-style-type: none"> • The battery has reached the end of the charging/discharging cycles declared by the manufacturer 	<ul style="list-style-type: none"> • replace the battery
---	---	---

<ul style="list-style-type: none"> • the battery has been recharged with too high a current 	<ul style="list-style-type: none"> • replace the battery
<ul style="list-style-type: none"> • the battery has been charged beyond the limit suggested by the Manufacturer 	<ul style="list-style-type: none"> • replace the battery

ALARMS ON THE DISPLAY:

ERROR CODE DISPLAYED	CAUSE	SOLUTION
BRUSH TEMPERATURE PAUSE	The machine has worked for too long at a high pressure	Wait 30 minutes for the temperature to drop
	The work programme being used is too heavy for the type of surface	Change from P3 to P2 or P1 (if P1 is already being used, follow the setting instructions to reduce the pressure)
	Electronics damaged	Replace the power board
BATTERY RESERVE	The battery voltage is <31.5V	Charge the battery
BATTERY FLAT	The battery voltage is <29V	Charge the battery
BATTERY EXHAUSTED	The battery voltage is <27V	Check the level of acid in the battery and charge
BRUSHES EXHAUSTED	The brushes are worn	Replace the brushes
	The floor is very smooth and the brush motor does not reach the required absorption	Change the work programme from P3 to P2 or P1
PARKING BRAKE	The parking brake is on	Release the parking brake
	The brake pedal microswitch is not mounted correctly	Adjust the position of the microswitch
	The brake pedal microswitch is not functioning correctly	Replace the microswitch
DIRTY WATER TANK LEVEL	The level sensor is activated by the water level	Empty the dirty water tank then reset the machine
	The level sensor is blocked in the CLOSED position	Check and if necessary replace the sensor
WATER RESERVE	The level sensor is activated by the water level	Prepare to empty the dirty water tank.
	The level sensor is blocked in the CLOSED position	Check and if necessary replace the sensor
NO WATER	The level sensor is activated by the water level	Fill the detergent tank, then reset the machine
		Check and if necessary replace the sensor

Motor drive alarm board

















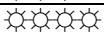







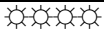



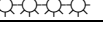

If the machine drive stops, control the status LED (fig. B, ref. 13) to identify the error code. In the absence of malfunctions, the status LED is lit steadily while the machine is in operation. If a malfunction is detected, the status LED provides two types of information, a slow flash (2 Hz) or a rapid flash (4 Hz) to indicate the severity of the malfunction.

Malfunctions with a slow flash are cancelled automatically once the malfunction has been repaired and the machine functions normally again. Malfunctions with a rapid flash ("*" in the table) are considered more serious. The machine must be turned of using the key switch (fig. B ref. 3) to reset operation after repairing the malfunction.

The indication of severity remains active for 10 seconds, after which the status LED flashes constantly showing a two digit malfunction code until the repairs have been carried out.

For example, error code "1,4" is displayed as follows:

 
 example alarm code 1,4

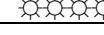
LED CODES			DESCRIPTION
*	1,1	 	Drive motor output malfunction - Overcurrent error
*	1,2	 	EEPROM malfunction, main contactor malfunction, malfunction of board components, incorrect drive motor voltage
	1,3	 	NOT USED
	1,4	 	NOT USED
	2,1	 	Incorrect machine start up sequence (with key)
	2,2	 	Incorrect machine start up sequence (with key)
*	2,3	 	Incorrect start up sequence for more than five seconds
	2,4	 	Malfunction of speed limiter potentiometer on control panel
	3,1	 	NOT USED
	3,2	 	NOT USED
	3,3	 	Accelerator pedal malfunction
	3,4	 	NOT USED
	4,1	 	Battery voltage too low (voltage < 21 V)
	4,2	 	Battery voltage too high (voltage > 48 V)
	4,3	 	Drive motor > 80°C thermal cutout tripped
	4,4	 	NOT USED

CT 230

CT 160

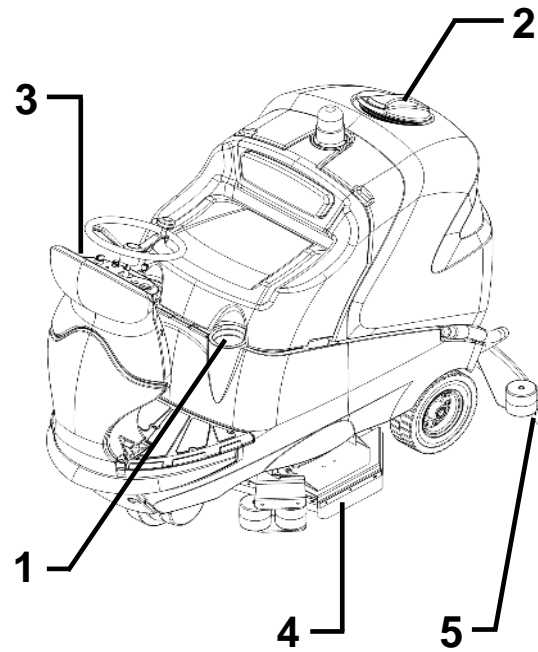
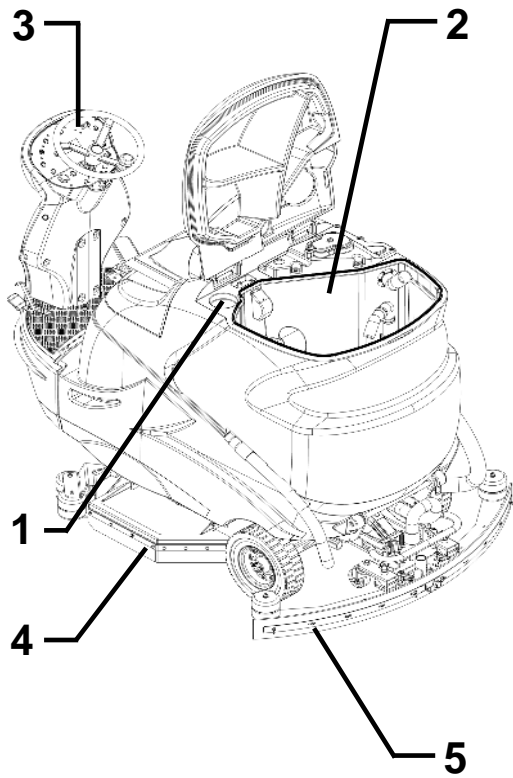

A

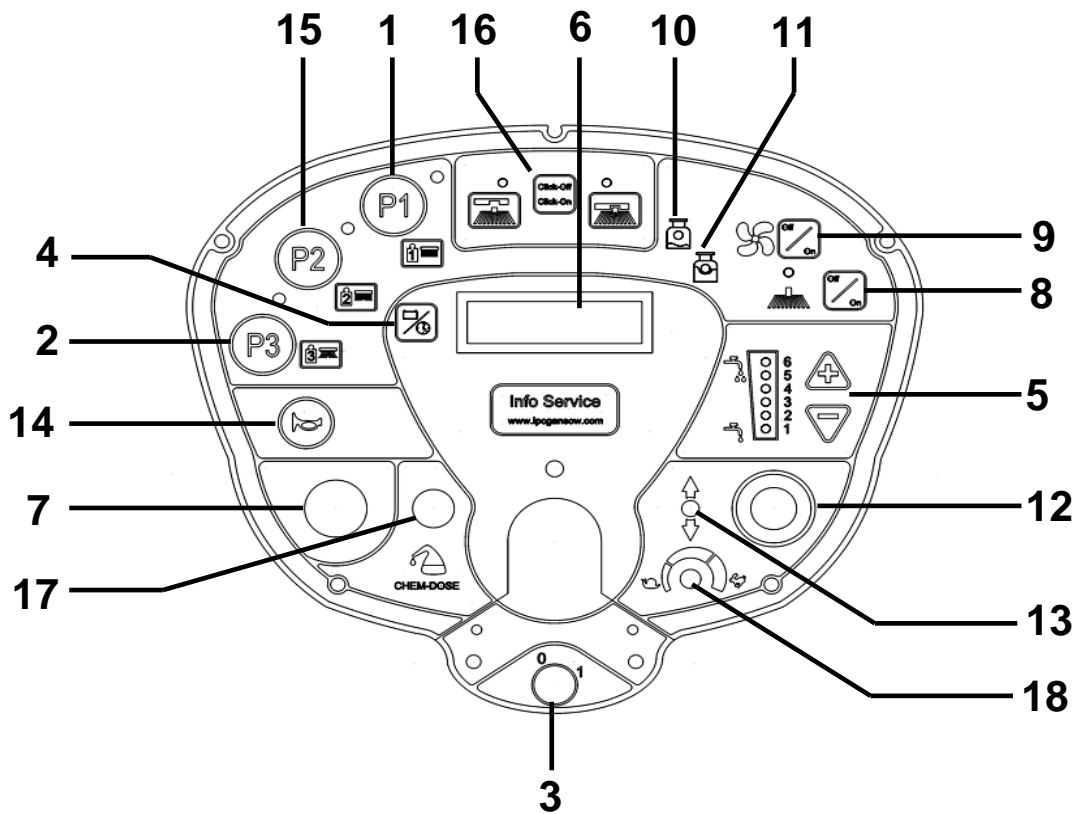

B

CT 230

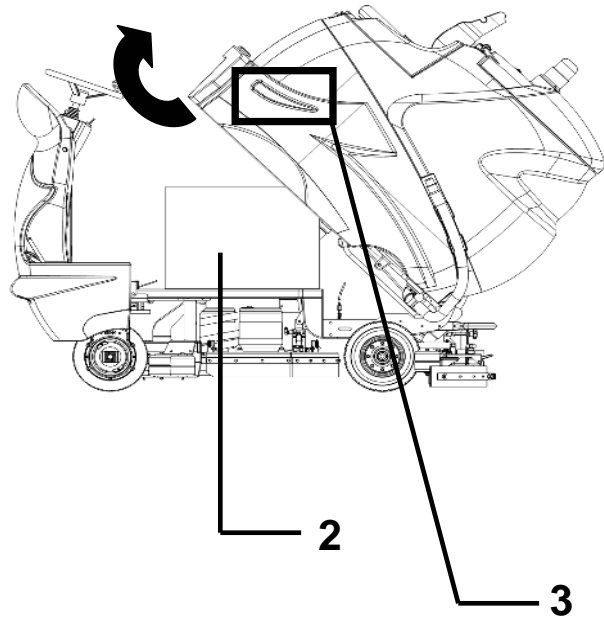
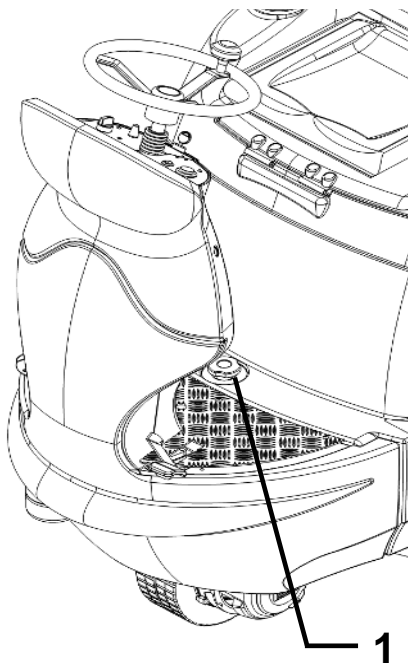

CT 160

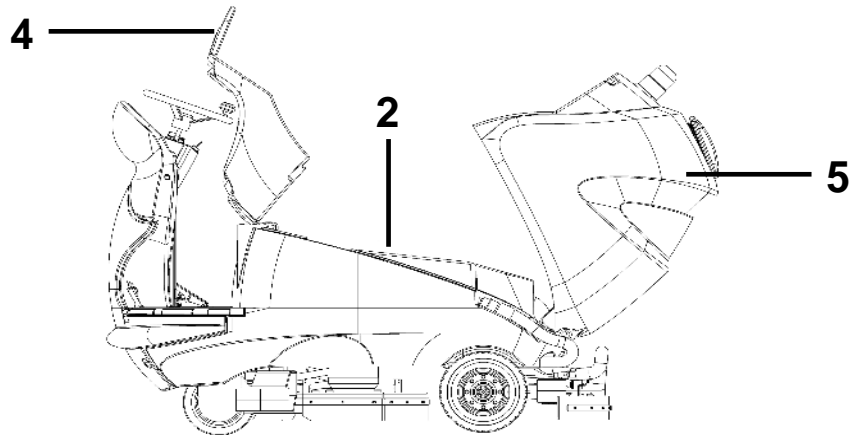

C

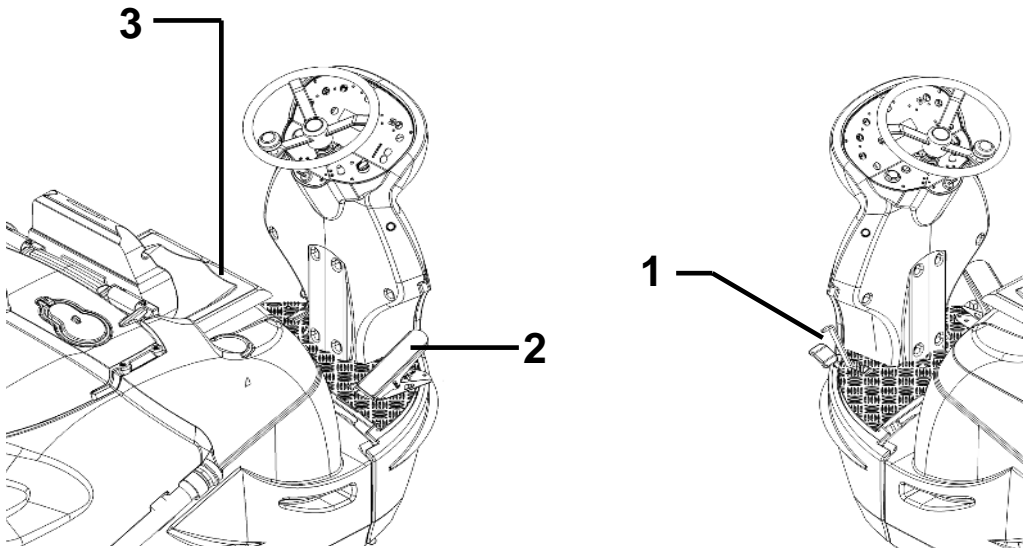

D

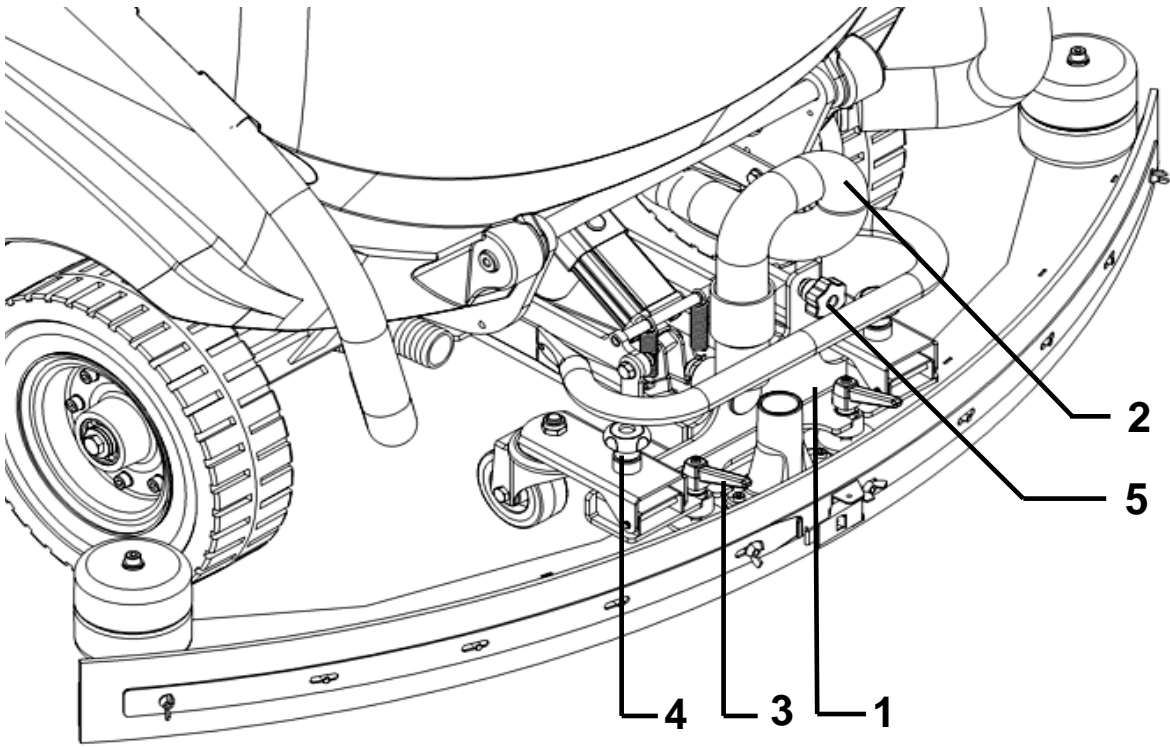

E

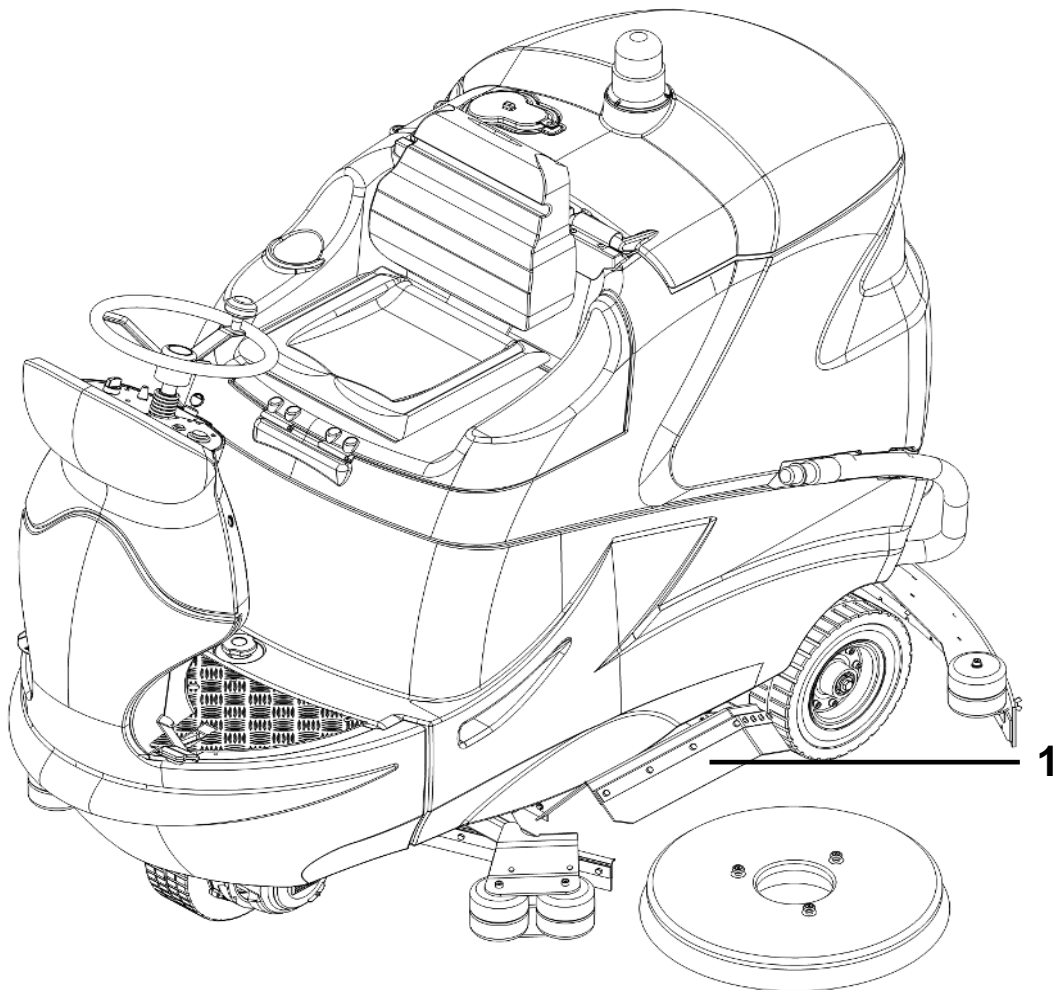

F

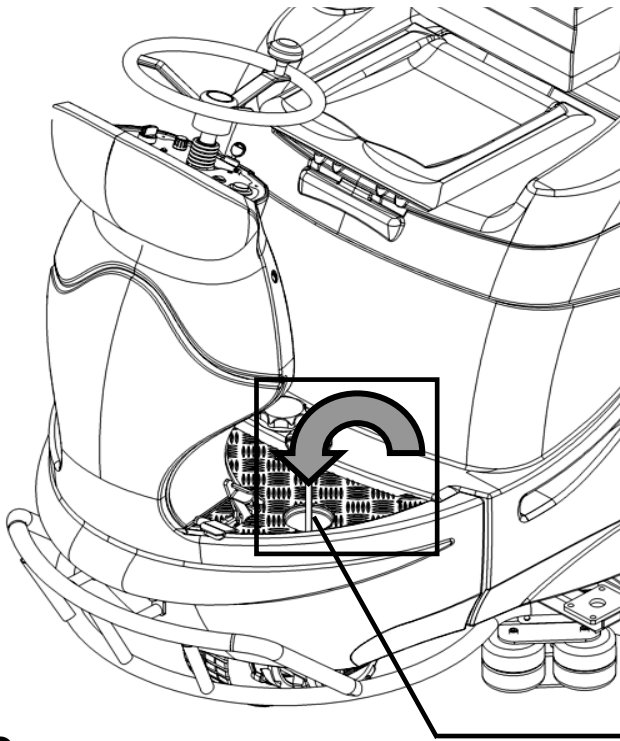
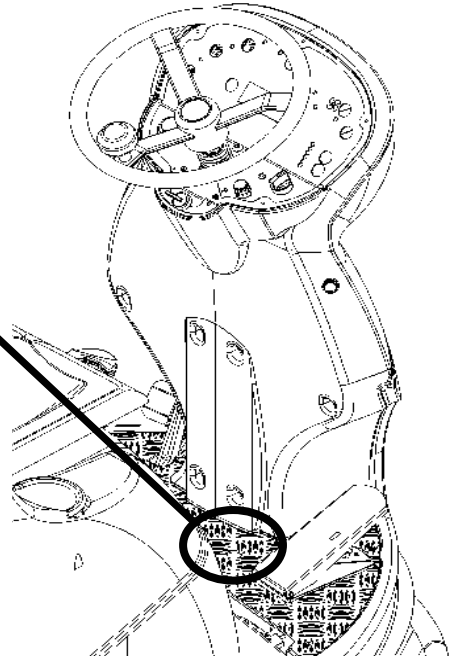
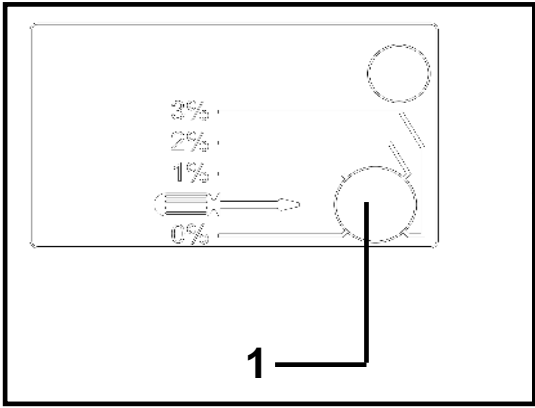

G

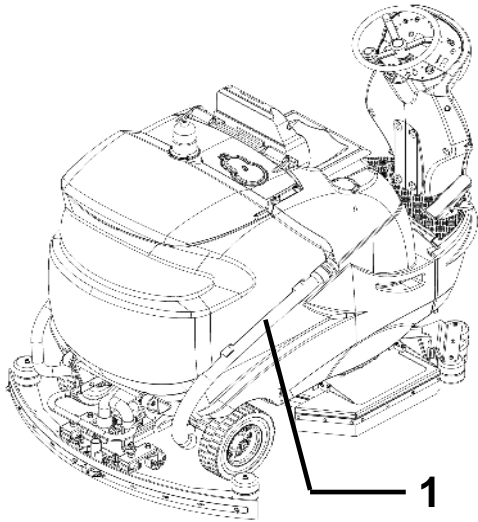

H

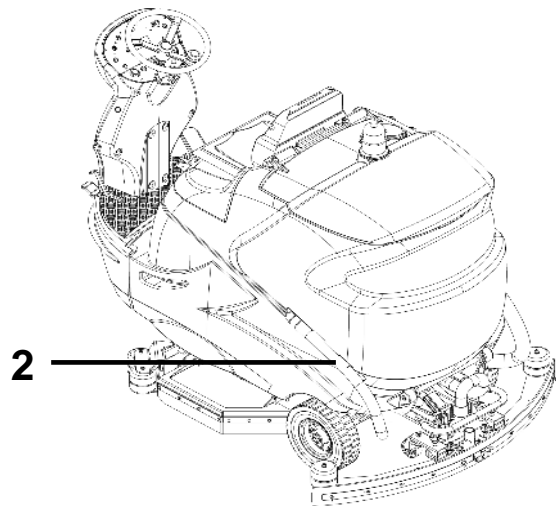

2

CT 230

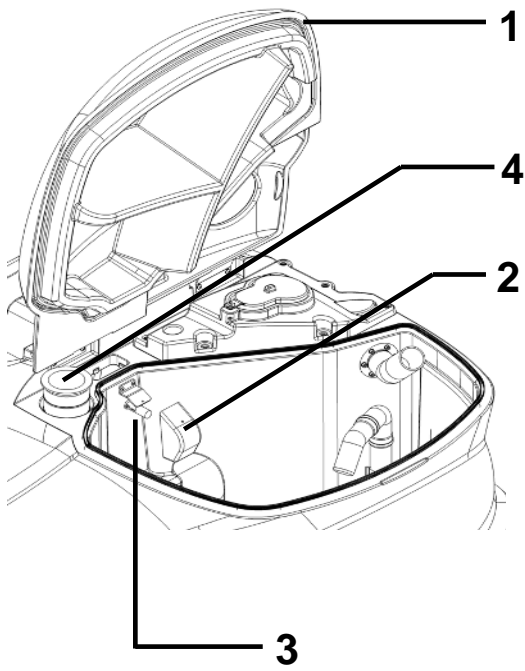

CT 160

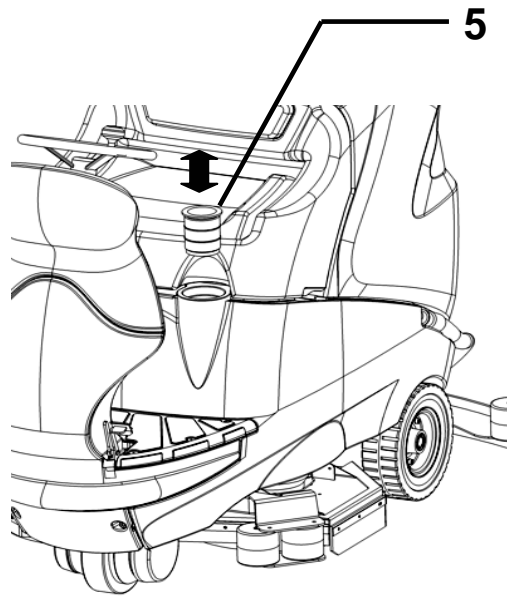

I

CT 230

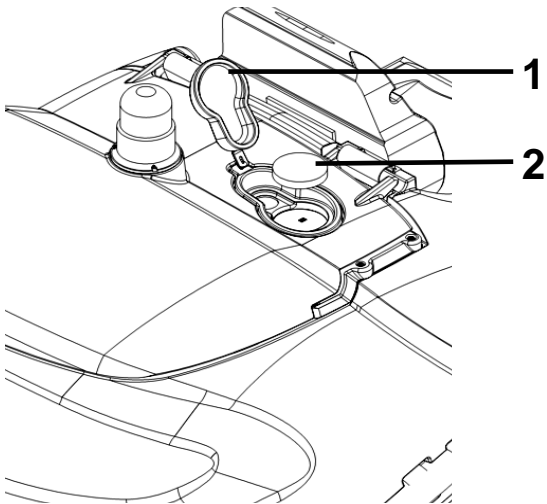

CT 160

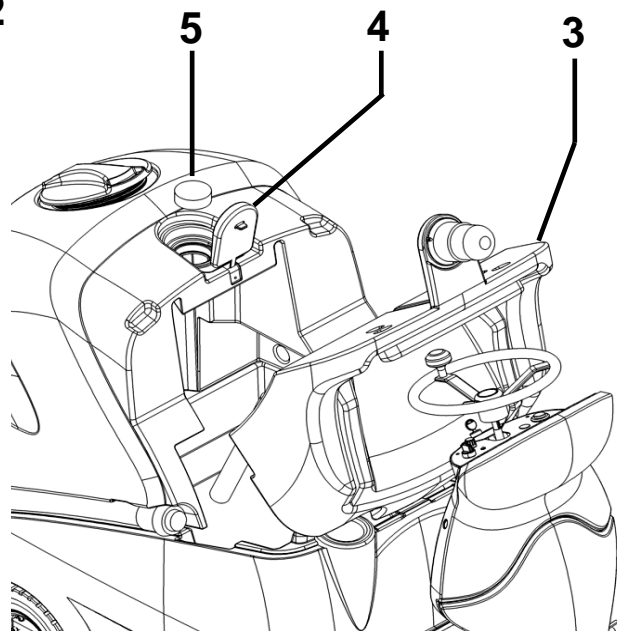

L

CT 230

CT 160

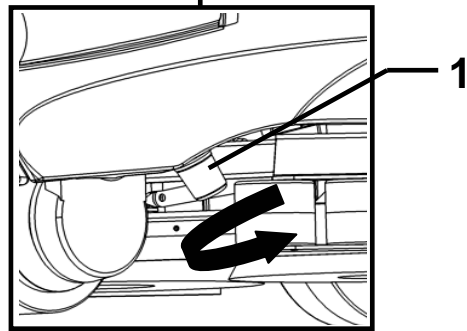
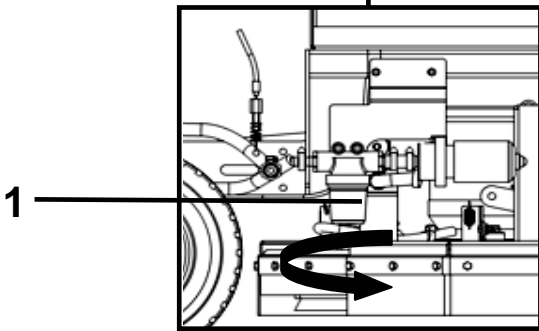
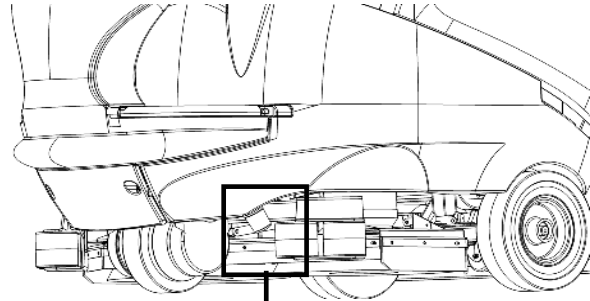
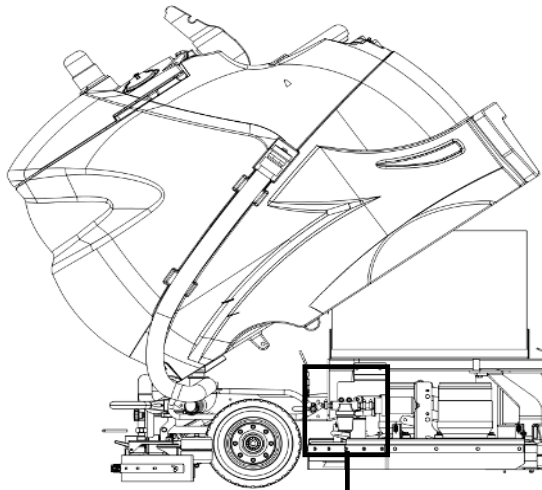

M

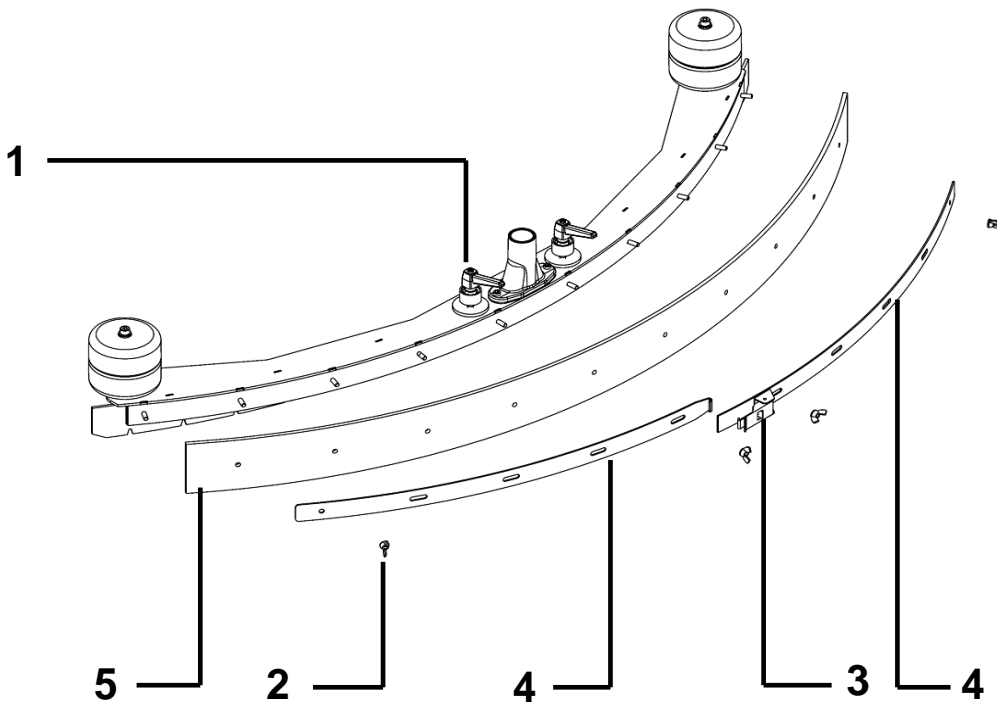

N

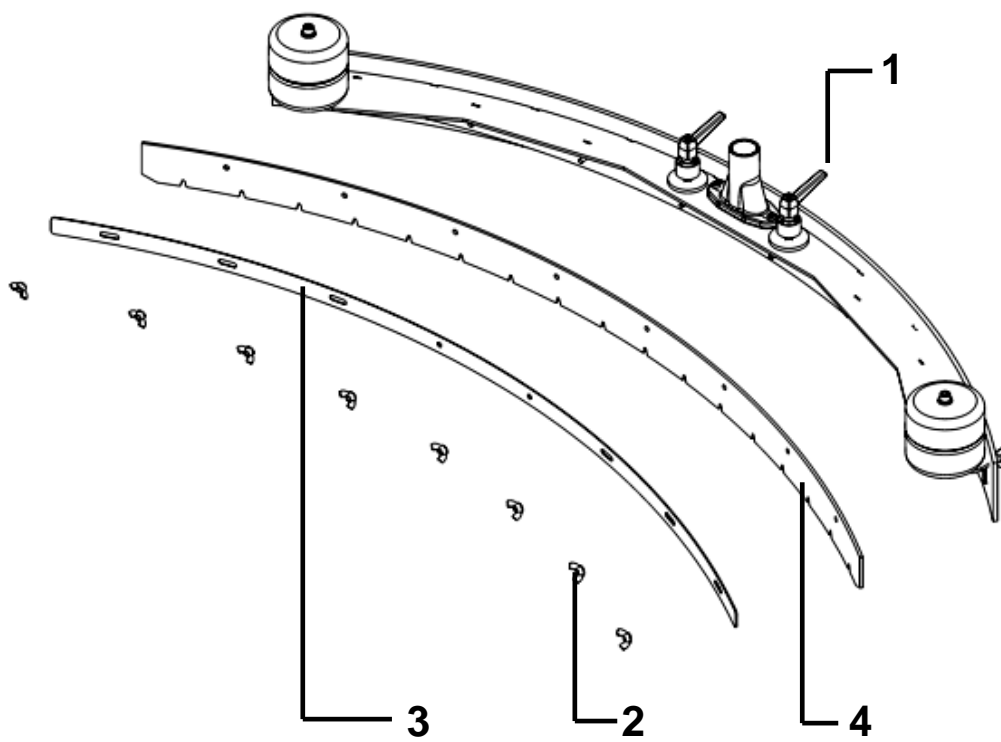

O

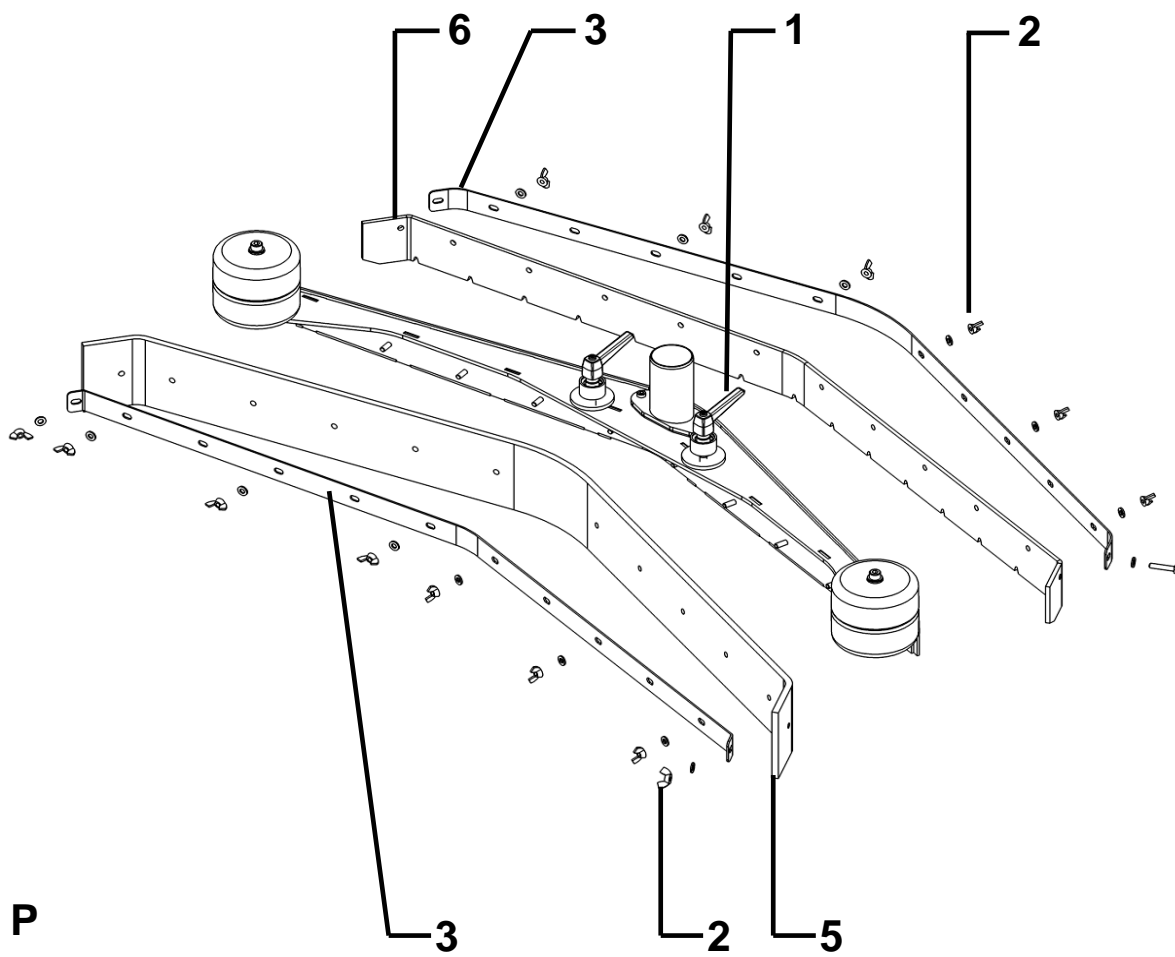

P

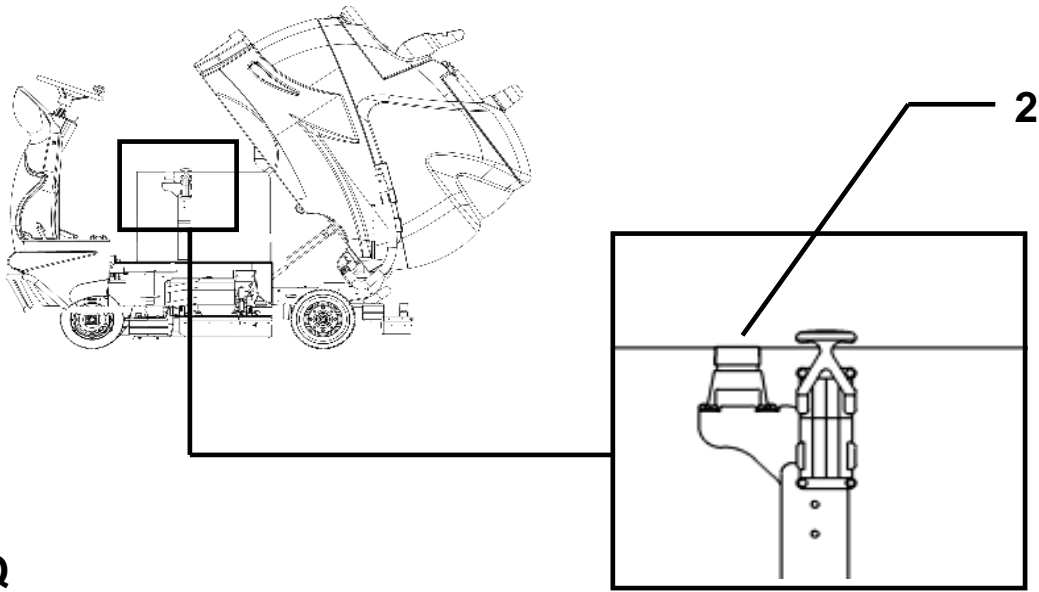
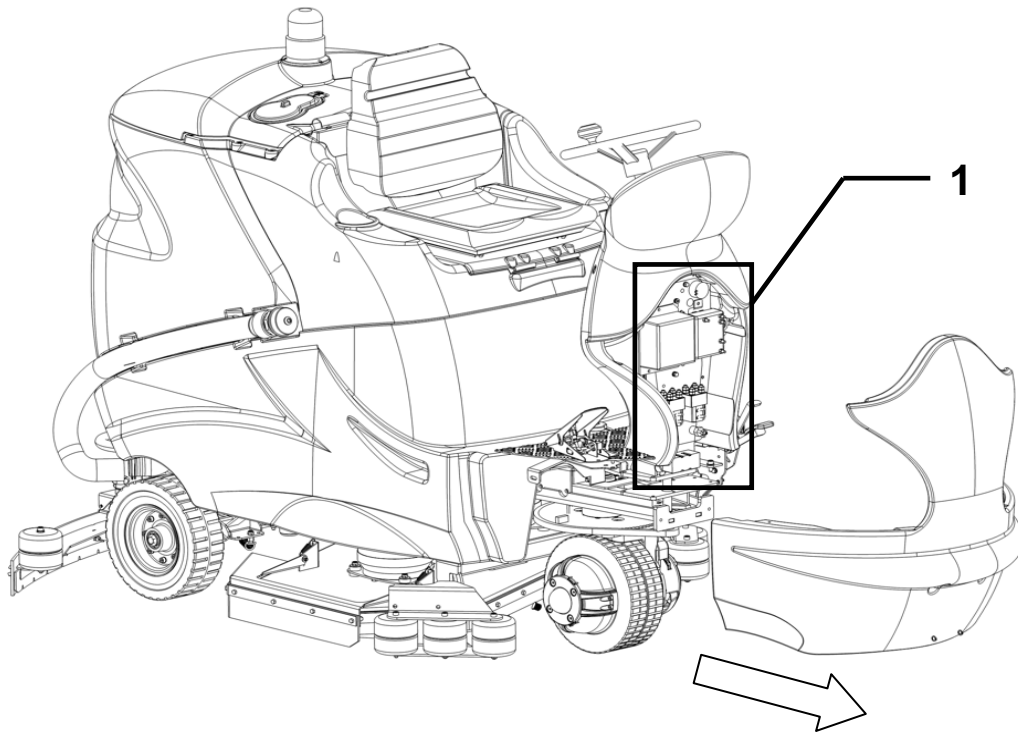

Q

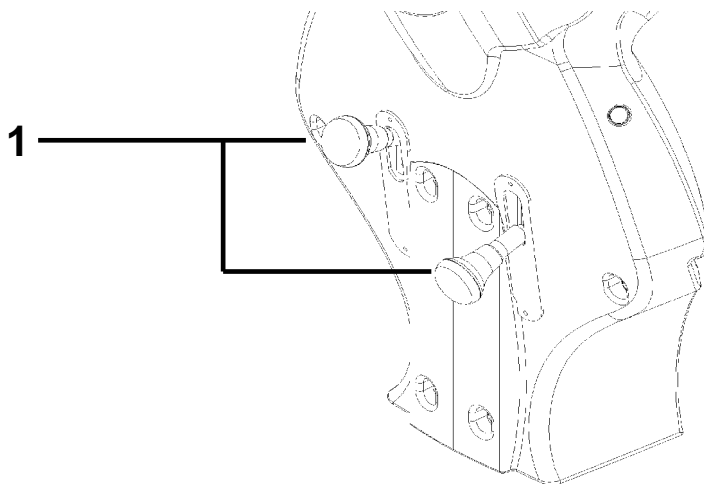

R

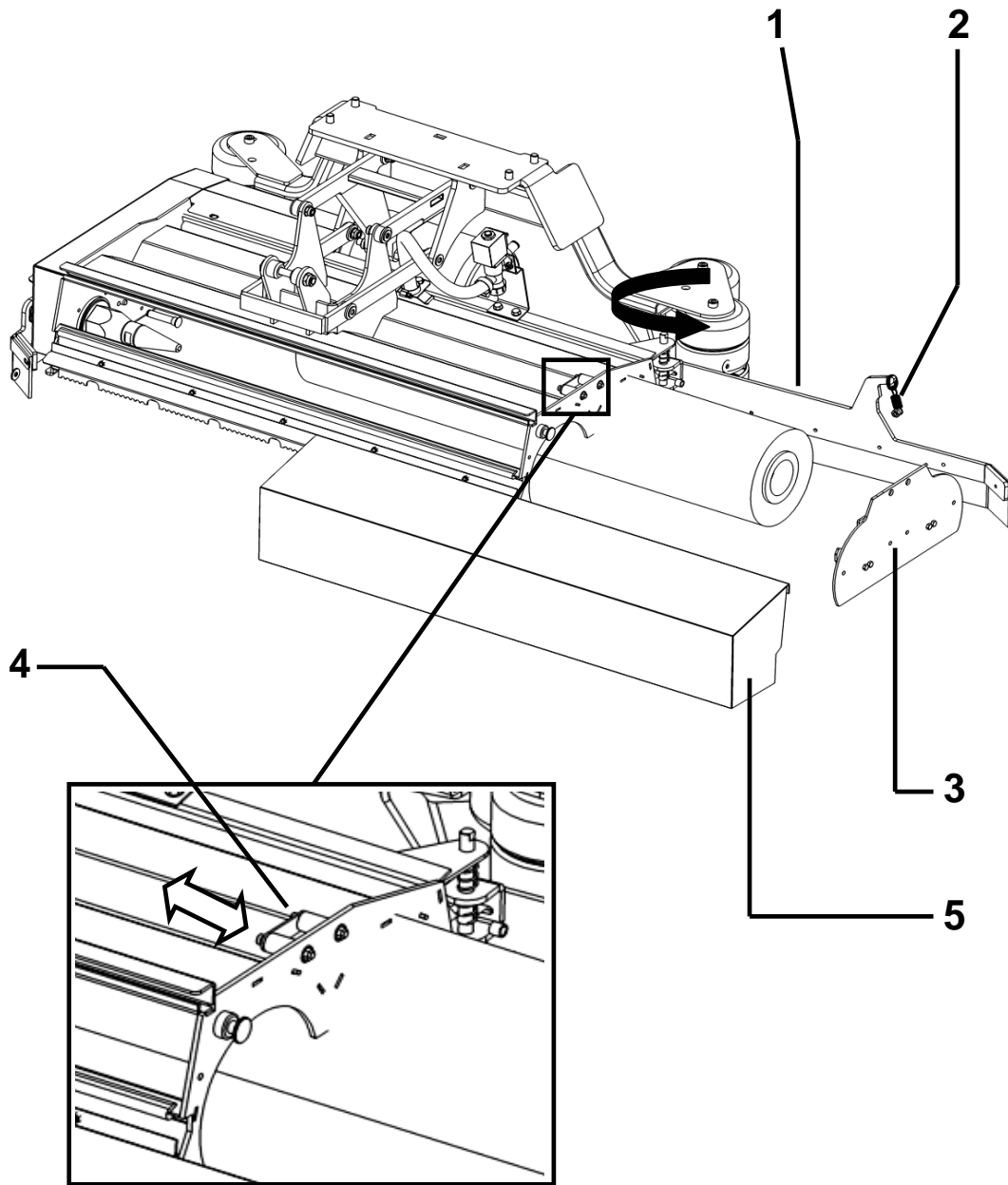

S

CT 230

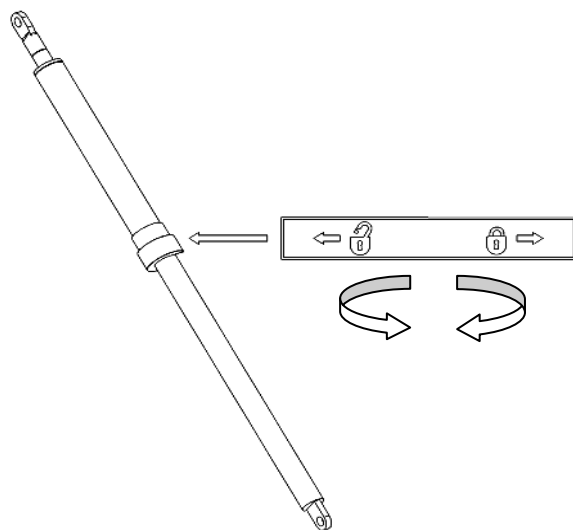

T