



Clemas & Co Ltd

Industrial Cleaning Equipment

Sales - Hire - Service

KERSTAR CV90 & CV200 GOBBLEVACS VACUUM CLEANER PARTS MANUAL



Clemas & Co. Unit 5 Ashchurch Business Centre, Alexandra Way, Tewkesbury,
Gloucestershire, GL20 8NB.

Tel: 01684 850777

Fax: 01684 850707

Email: info@clemas.co.uk

Web: www.clemas.co.uk

KV90/2 & KV200/2 GOBBLEVAC

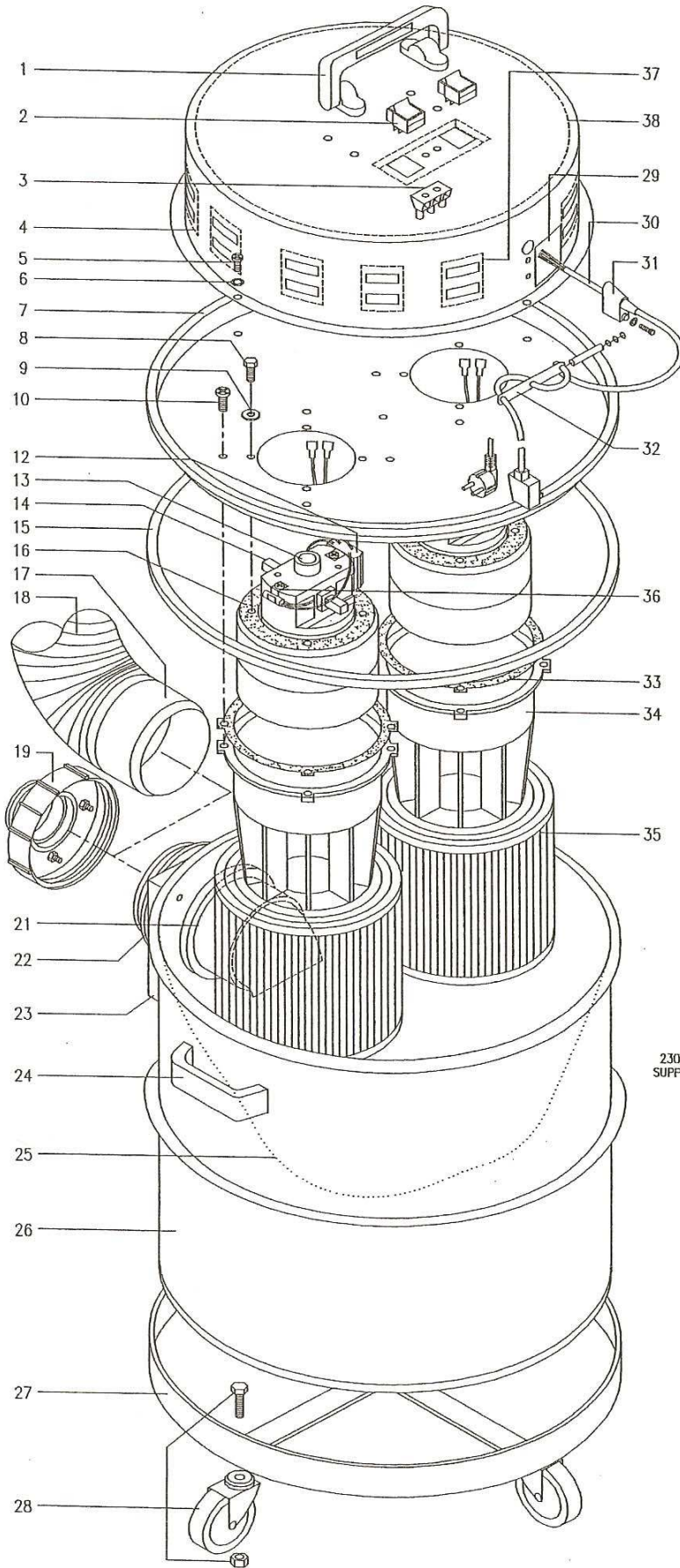

ITEM No	QTY	DESCRIPTION
1	1	FLIP FLOP HANDLE ASSY
2	2	DRY VAC ROCKER SWITCH
3	1	TERMINAL BLOCK
4	1	TOP PRESSING (INC. HANDLE) FOR KV90/2 & KV200/2
5	4	M4 x 10 PAN HEAD SCREW BZP
6	4	M4 INTERNAL SHAKEPROOF WASHER BZP
7	1	18" MOTOR PLATE FOR KV90/2 (INC. RUBBER SEAL)
7	1	22 1/2" MOTOR PLATE FOR KV200/2 (INC. RUBBER SEAL)
8	8	M5 x 12 TAPTITE THREAD FORMING SCREW BZP
9	8	3/4" OD x 3/16" ID WASHER BZP
10	8	No. 10 x 3/4" PAN POZI PLASTITE BZP
11		NOT APPLICABLE TO THIS MODEL
12A	2	230V FILTER/THERMAL SWITCH (M1/608 TYPE)
12B	2	110V FILTER/THERMAL SWITCH (M1/619 TYPE)
13A	2	230V 1,000W DIRECT AIRFLOW MOTOR
13B	2	110V 1,000W DIRECT AIRFLOW MOTOR
14A	1PR	CARBON BRUSHES FOR 230V 1,000W D.A.F MOTOR
14B	1PR	CARBON BRUSHES FOR 110V 1,000W D.A.F MOTOR
15	1	FOAM RUBBER SEAL FOR MOTOR PLATE:- KV90/2 = 1.6MTR KV200/2 = 2MTR
16	2	MOTOR TO MOTOR PLATE GASKET
17	1	100mm MACHINE HOSE END
18	1	100mm SEE THRU EXTRACTION HOSE-PER METRE
19	1	SCREW ON 100mm HOSE TO MKII SPIGOT CONVERTER
20		NOT APPLICABLE TO THIS MODEL
21	1	100mm INTERNAL BEND/DEFLECTOR
22	1	100mm HOSE INLET (EXCL. ITEM No.19)
23	1	CURVED ADAPTER PLATE FOR KV90/2 & KV200/2
24	2	CURVED SURFACE HANDLE WITH BOLTS & WASHERS
25A	1	18" PERMAFLOW FILTER FOR KV90/2
25B	1	22 1/2" PERMAFLOW FILTER FOR KV200/2
26A	1	CAN ASSY FOR KV90/2 (INC. HOSE ENTRY, SCREW CAP & HANDLE)
26B	1	CAN ASSY FOR KV200/2 (INC. HOSE ENTRY, SCREW CAP & HANDLE)
27A	1	CHASSIS COMPLETE WITH 4 CASTORS FOR KV90/2
27B	1	CHASSIS COMPLETE WITH 4 CASTORS FOR KV200/2&3
28	4	75mm (3") CASTOR WITH M10 x 30 BOLT & M10 NYLOC
29		"DRY VAC ONLY" LABEL
30A	1	CABLE/UK 13A PLUG PACK 1.5 3 CORE x 10M
30B	1	CABLE/SCHUKO EUROPEAN PLUG PACK 1.5 3 CORE x 10m
31	1	CABLE CLAMP (INC. SCREW & RUBBER GROMMET)
32	1	CABLE RESTRAINT
33	2	"LOBSTER POT" FILTER CAGE TO MOTOR PLATE GASKET
34	2	"LOBSTER POT" FILTER CAGE
35	2	PUSH ON HIGH EFFICIENCY (0.5 MICRON) CARTRIDGE FILTER
36	2	RETAINING CLIP FOR THERMAL SWITCH
37	1	FOAM SILENCING RECTANGULAR
38	1	FOAM SILENCING CIRCULAR

WIRING DIAGRAM

