

Clemas
CLEANING MACHINES

i-mop XXL Parts Manual



Unit 16 Alexandra Way, Ashchurch Business Centre,
Tewkesbury, GL20 8NB

Phone No. 01684 850 777 Email. info@clemas.co.uk

Website. www.clemas.co.uk

1	2		3		4		5		6	
Revision	Description		Revised	Date						
A	FIRST RELEASE		CONNIE	29/Aug/2019						
				PAGE		1 / 21				

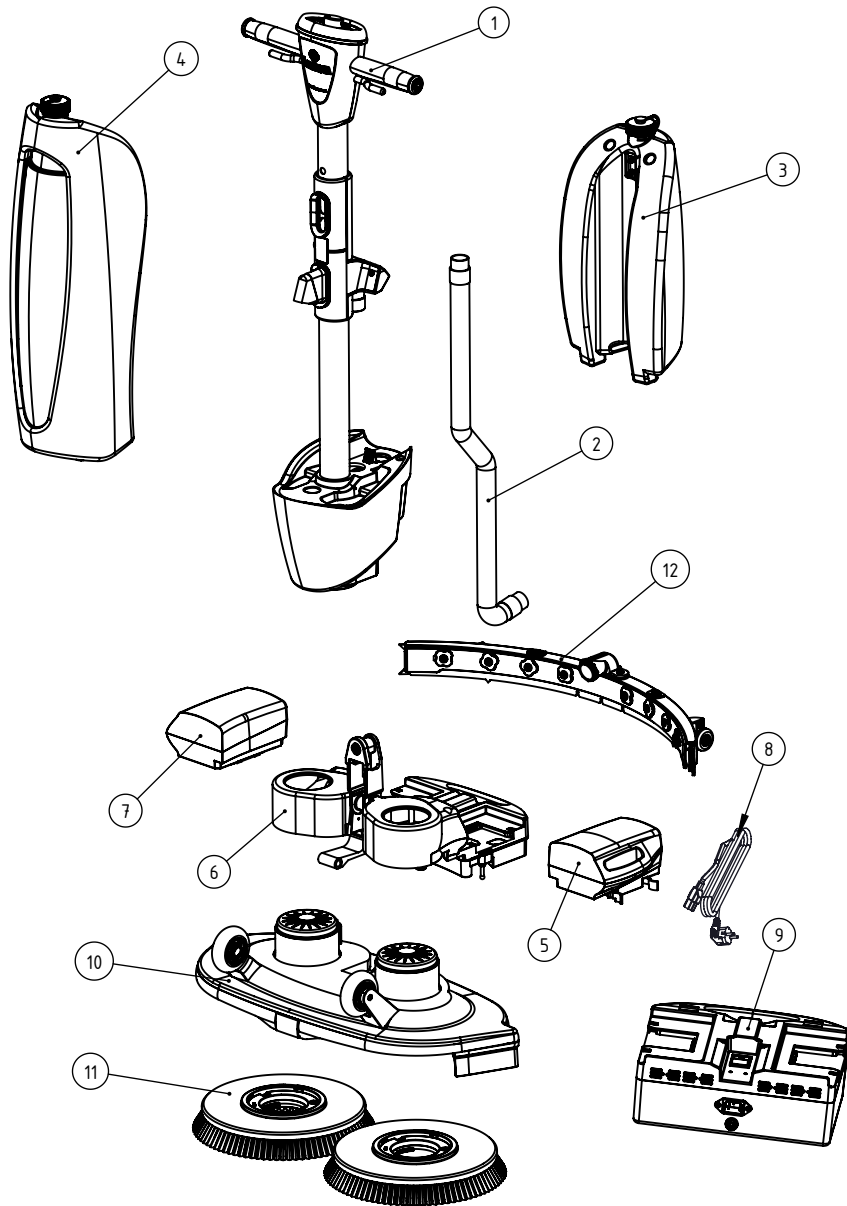

Item	P/N	Description	Qty.
1	TU.IMOPXXL.230.2/797	ASSY TOP UNIT IMOP, BLUE BUTTON	1
2	S.72.0094.0	STRETCH HOSE COMPLETE	1
3	S.72.1081.0A	ASSY CLEAN COMPARTMENT COMPLETE + FILLING HOSE	1
4	S.72.1088.0F	DIRT COMPARTMENT XXL FLOAT BALL	1
5	S.72.0079.357BSRA	ASSY BATTERY PACK GREY [RIGHT] BMS 14Ah [FR][W/O FUSE]	1
6	S.72.1065.21	ASSY MAIN LEVER UNIT IMOPXXL MERCURY SWITCH	1
7	S.72.0074.357BSRA	ASSY BATTERY PACK GREY [RIGHT] BMS 14Ah [FR][W/O FUSE]	1
8	72.0152.0	POWER CORD EUR 1.5 METER CB 3PIN	1
9	S.72.0344.3	IMOP BATTERY MCU CHARGER 3 PIN [9A] PSE+CB	1
10	BU.IMOPXXL.230.36	ASSY BRUSH UNIT IMOPXXL 24V SILVER	1
11	S.72.1092.797/797	ASS BRUSH IMOPXXL COMPLETE BLUE BRISTLE, BLUE LOCKER	2
12	S.72.1096.2	SQUEEGEE ASSEMBLY RYTON BLACK CASTOR XXL	1
13	72.0042.2099.00A NO SHOW	MANUAL IMOP XXL [ENGLISH]	1
14	72.0042.2099.20 NO SHOW	MANUAL IMOP MCU 9A CHARGER [ENGLISH]	1
15	72.0142.11 NO SHOW	DAMP-PROOF BAG 30g	2

TOLERANCES UNSPECIFIED		REMARK: -		SMT-FCT DONGGUAN THE FRIENDLY FAMILY 东莞硕能塑胶模具有限公司 ASSEMBLY AND MOULDING OF CLEANING					
LINE	ANGLE	MATERIAL: -							
.xxx ±0.005	x ±2°	APPROVED	CHECKED	DISGNE	REV.	A	PART NAME	IMOPXXLN.FCT.7 EXPLODED VIEW	
.xx ±0.05	.x ±1.5°			CONNIE	UNIT	mm	PART NO	IMOPXXLN.FCT.7	SIZE
.x ±0.1	.xx ±1°				SCALE		PROJECT		A4
. ±0.2	.xxx ±0.5°								
xx ±0.5									
xxx ±1									
SHEET 1 OF 1	DATE			29/Aug/2019					

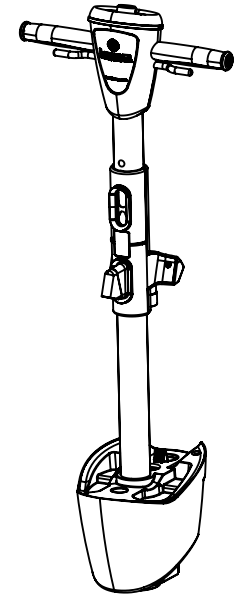
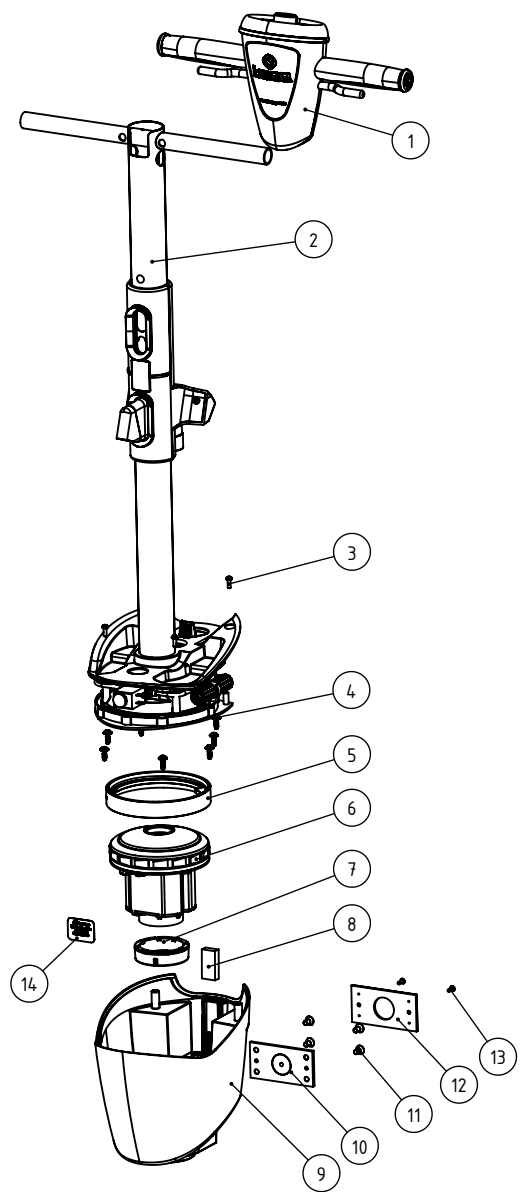

Item	P/N	Description	Qty.
	TU.IMOPXXL.230.2/797	ASSY TOP UNIT IMOP, BLUE BUTTON	
1	S.72.1059.2/797	ASSY CONTROL UNIT XXL, BLUE	1
2	S.72.1040.0	ASSY INLET TUBE XXL	1
3	72.0121.1	SCREW M4X12, CROSS HEAD, STANDARD THREAD, SST	4
4	72.0026.0	SCREW WN 5451 50X14 EJOT DELTA PT	8
5	72.0112.0/A	VACUUM MOTOR SEALING SUPPORT [VER1]	1
6	72.0035.0	DOMEL VACUUM CLEANER MOTOR [69.0007.0]	1
7	72.0034.0	VACUUM MOTOR SEALING BOTTOM [MCH 1416-1001-2047]	1
8	72.0051.0	MAGNET TOP UNIT 40X20X10MM [MCH 1416-1001-2044]	1
9	72.0111.357	MOTOR UNIT COVER [MCH 1416-1001-2118], Kleur: Grey .357 P43	1
10	S.72.0031.2A	HINGE WELDING ASSY TOP UNIT [Ver2]	1
11	72.0033.1	COUNTER SUNK HEAD CAP SCREW M6X12 WITH NYLOK GLUE	4
12	72.0241.357	PLASTIC PLATE FOR HINGE WELDING ASSY, Kleur: Grey .357 (P431)	1
13	72.0240.0	COUNT SUNK SCREW M3.5X13 PHILPS HEAD	2
14	89.0467.2099.02	SERIAL NO. VACUUM MOTOR	1

TOLERANCES UNSPECIFIED		REMARK: -		 东莞硕能塑胶模具有限公司 ASSEMBLY AND MOULDING OF CLEANING			
LINE	ANGLE	-		MATERIAL: -			
.xxx	±0.005	x	±2°	APPROVED	CHECKED	DISGNE	REV. A
.xx	±0.05	.x	±1.5°			CONNIE	UNIT mm
.x	±0.1	.xx	±1°				PART NAME IMOPXXLN.FCT.7 EXPLODED VIEW
.	±0.2	.xxx	±0.5°				PART NO IMOPXXLN.FCT.7
xx	±0.5						SIZE
xxx	±1						A4
SHEET OF		DATE		29/Aug/2019		SCALE	

Revision	Description	Revised	Date
A	FIRST RELEASE	CONNIE	29/Aug/2019

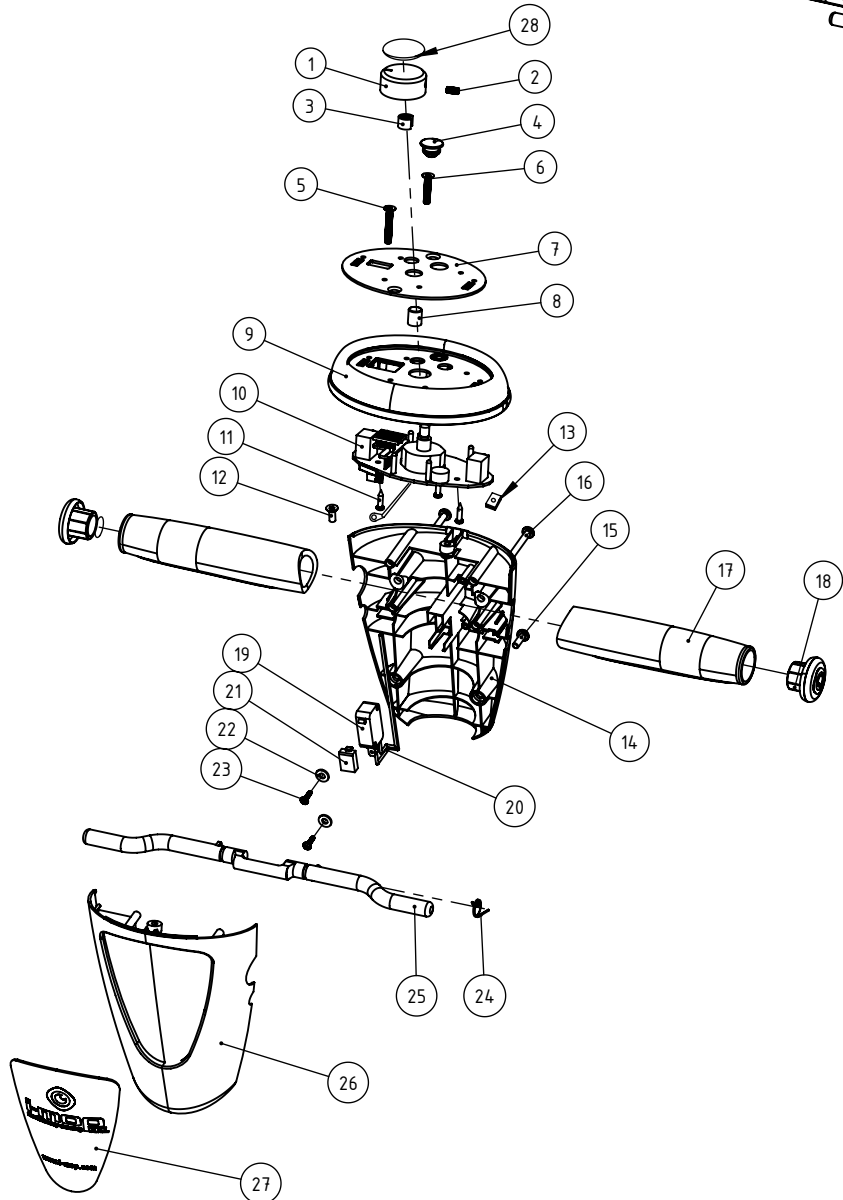

Item	P/N	Description	Qty.
	S.72.1059.2/797	ASSY CONTROL UNIT XXL, BLUE	
1	72.0155.5/797	TURNING BUTTON NODIC OXIDATION M:AL, BLUE P312C	1
2	00.0115.0	HEXAGON SOCKET SET SCREW M4 X 8	1
3	72.0272.0	FIXATION INSERT TURNING BUTTON	1
4	72.0225.0/A	RUBBER BLOCK WATER SAVE ADJUSTMENT HOLE [A]	1
5	72.0273.0	M4X25 COUNTERSUNK SCREW STAINLESS STEEL	1
6	72.0273.1	M4X20 COUNTERSUNK SCREW STAINLESS STEEL	1
7	89.0467.2099.00C	AL. STICKER IMOP XXL [PLATE] [C]	1
8	72.0203.0	WATER SAVE BUTTON	1
9	72.0061.2E	TOP HOUSING CONTROL UNIT COLOR: WHITE + TIMER FRAME [E]	1
10	72.0062.0/TA	ASSY PCB LOCK CONNECTOR CONTROL UNIT BELT TIMER	1
11	85.1008.1	SCREW M3 X12 CROSSHEAD SELFTAPPING BL-NI, SST	1
12	00.0002.7	SCREW 4 X 10	3
13	72.0263.0	SWITCH WIRE CLAMP, Kleur: Black	1
14	72.0059.2C	REAR HOUSING CONTROL UNIT Color: White [C]	1
15	72.0121.1	SCREW M4X12, CROSS HEAD, STANDARD THREAD, SST	2
16	72.0122.1	SCREW M4X35, CROSS HEAD, STANDARD THREAD, SST	2
17	72.1230.357	HANDLE GRIP XXL, Kleur: Grey .357 (P431C)	2
18	72.0229.797	END CAP GRIP WITH LOGO, Kleur: Blue .797 (P312C)	2
19	72.0060.2	POWER SWITCH CONTROL UNIT OMORON	1
20	72.0120.0	ON/OFF SWITCH WIRES / L=250MM	1
21	72.0211.2	RUBBER BLOCK 15x10x5mm INJECTED	1
22	72.0271.0	PLASTIC WASHER 9x4x1mm	2
23	72.0057.0	SCREW WN 5451 25X10 EJOT DELTA PT [MCH 1416- 1001-2150]	2
24	72.0228.1	SPRING_SWITCH LEVER DIA.0.8MM (Ver.1)	1
25	72.0063.797	HANDLE CONTROL UNIT [MCH 1416-1001-2065], Kleur: Blue .797	1
26	72.0064.2B	FRONT HOUSING CONTROL UNIT Color: White [B]	1
27	S.89.0467.2099.01G	ASSY AL.PLATE STICKER G XXL WITH CLIP + 3M TAPES [HANDLE]	1
28	89.0469.2099.24	REMOVE STICKER ON THE SWITCH	1

TOLERANCES UNSPECIFIED		REMARK:		SMT-FCT DONGGUAN THE FRIENDLY FAMILY 东莞硕能塑胶模具有限公司 ASSEMBLY AND MOULDING OF CLEANING							
LINE	ANGLE	-						MATERIAL: -			
.xxx	±0.005	x	±2°	APPROVED	CHECKED	DISGNE	REV.	A	PART NAME	IMOPXXLN.FCT.7 EXPLODED VIEW	
.xx	±0.05	.x	±1.5°			CONNIE	UNIT	mm	PART NO	IMOPXXLN.FCT.7	SIZE
.x	±0.1	.xx	±1°				SCALE		PROJECT		A4
.	±0.2	.xxx	±0.5°								
xx	±0.5										
xxx	±1										
SHEET 1 OF 1		DATE		29/Aug/2019		SCALE		PROJECT			

A

B

C

D

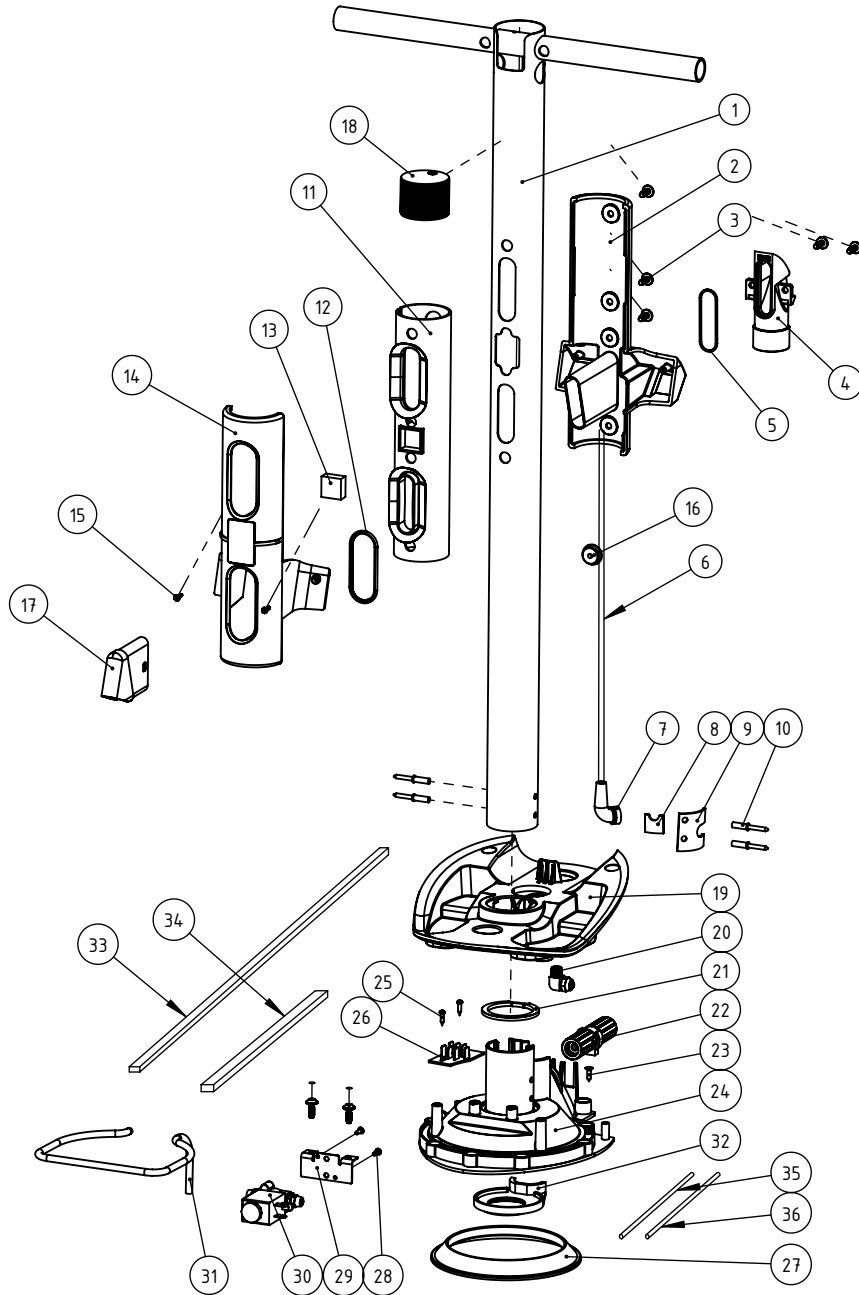

Item	P/N	Description	Qty.
	S.72.1040.0	ASSY INLET TUBE XXL	
1	S.72.1041.0A	ASSY INLET TUBE WELDING - 1 PIECE XXL	1
2	72.0055.357	TANK HOLDER REAR [MCH 1416-1001-2197], Kleur: Grey .357	1
3	72.0026.0	SCREW WN 5451 50X14 EJOT DELTA PT	6
4	72.0056.357	STRETCH HOSE CONNECTOR [MCH 1416-1001-2199], Kleur: Grey .35	1
5	72.0296.0	GASKET FOR HOSE CONNECTOR	1
6	S.72.0039.0/D	ASSY UTP CABLE (PVC+FIBRE) RJ45	1
7	72.0042.0	POWER CABLE GUIDING RUBBER [MCH 1416-1001-2187]	1
8	72.0268.0	SEALING RUBBER SHEET AL TUBE	1
9	72.0267.0	SEALING PRESSUR PLATE	1
10	72.0119.0	RIVET WITH DIA. 5MM & LENGTH 10 MM	4
11	72.0052.0	DIRT COMPARTMENT SEAL [MCH 1416-1001-2081]	1
12	72.0160.0	O RING WIRE DIA.3MM, OD46MM	1
13	72.0053.0	MAGNET TOP UNIT SMALL 20X20X10MM [MCH 1416-1001-2172]	1
14	72.0054.357	TANK HOLDER FRONT [MCH 1416-1001-2196], Kleur: Grey .357	1
15	72.0057.0	SCREW WN 5451 25X10 EJOT DELTA PT [MCH 1416-1001-2150]	2
16	72.0246.0	SEALING RING SIGAR UTP CONNECTOR	1
17	72.0163.1/996	TRANSPARENT PLASTIC DEFLECTOR DIRTY TANK	1
18	72.0038.0A	END CAP INLET TUBE [MCH 1416-1001-2152]	1
19	S.72.0113.357B	ASSY MOTOR UNIT TOP	1
20	72.0049.1	ANGLE METAL CONNECTOR	1
21	72.0044.0	MOTOR UNIT FRAME RUBBER [MCH 1416-1001-2189]	1
22	S.72.0243.0	ASSEMBLY SIGAR UTP CONNECTOR	1
23	72.0240.0	COUNT SUNK SCREW M3.5X13 PHILPS HEAD	1
24	72.0114.357	MOTOR UNIT FRAME [MCH 1416-1001-2122], Kleur: Grey .357	1
25	85.1008.1	SCREW M3 X12 CROSSHEAD SELFTAPPING BL-NI,SST	1
26	72.0182.0/A	PCB MAGNETIC VALVE & VAC MOTOR CONNECTION [A]	1
27	72.0045.0/A	VACUUM MOTOR SEALING TOP SHARE HARDNESS 45	1
28	72.0206.1	SCREW WN 5451 50X14 EJOT DELTA PT	2
29	72.0050.1A	MAGNETIC VENTIL FIXATION PLATE STAINLESS STEEL	1
30	S.72.0026.6	ASSY MAGETIC VALVE PARKER	1
31	72.0022.2	WATER CHANNEL DIA.6MM L:225mm	1
32	72.0352.0	CENTER SEALING GASKET TOP VACUUM MOTOR	1
33	72.0209.0B	SEALING GASKET EVA 3X1.5X593MM	1
34	72.0210.0B	SEALING GASKET EVA 4X2.5X150MM	1
35	72.0127.0	187 TERMINAL + WIRE 14AWG, RED, L=280mm, 250 TERMINAL	1
36	72.0128.0	187 TERMINAL + WIRE 14AWG, BLACK, L=280mm, 250 TERMINAL	1
37	00.0117.0 NO SHOW	GULE ND401	1
38	72.0232.0 NO SHOW	THREAD SEALING ADHESIVE	0.02

TOLERANCES UNSPECIFIED		REMARK:		SMT-FCT_DONGGUAN THE FRIENDLY FAMILY 东莞硕能塑胶模具有限公司 ASSEMBLY AND MOULDING OF CLEANING			
LINE	ANGLE	-		MATERIAL: -			
.xxx ±0.005	x ±2°	APPROVED	CHECKED	DISGNE	REV.	A	PART NAME
.xx ±0.05	.x ±1.5°			CONNIE	UNIT	mm	IMOPXXLN.FCT.7 EXPLODED VIEW
.x ±0.1	.xx ±1°						PART NO
. ±0.2	.xxx ±0.5°						IMOPXXLN.FCT.7
xx ±0.5							SIZE
xxx ±1							A4
SHEET OF	DATE	29/Aug/2019		SCALE	PROJECT		

1	2		3		4		5		6	
Revision	Description		Revised	Date						
A	FIRST RELEASE		CONNIE	29/Aug/2019						
					PAGE 5 / 21					

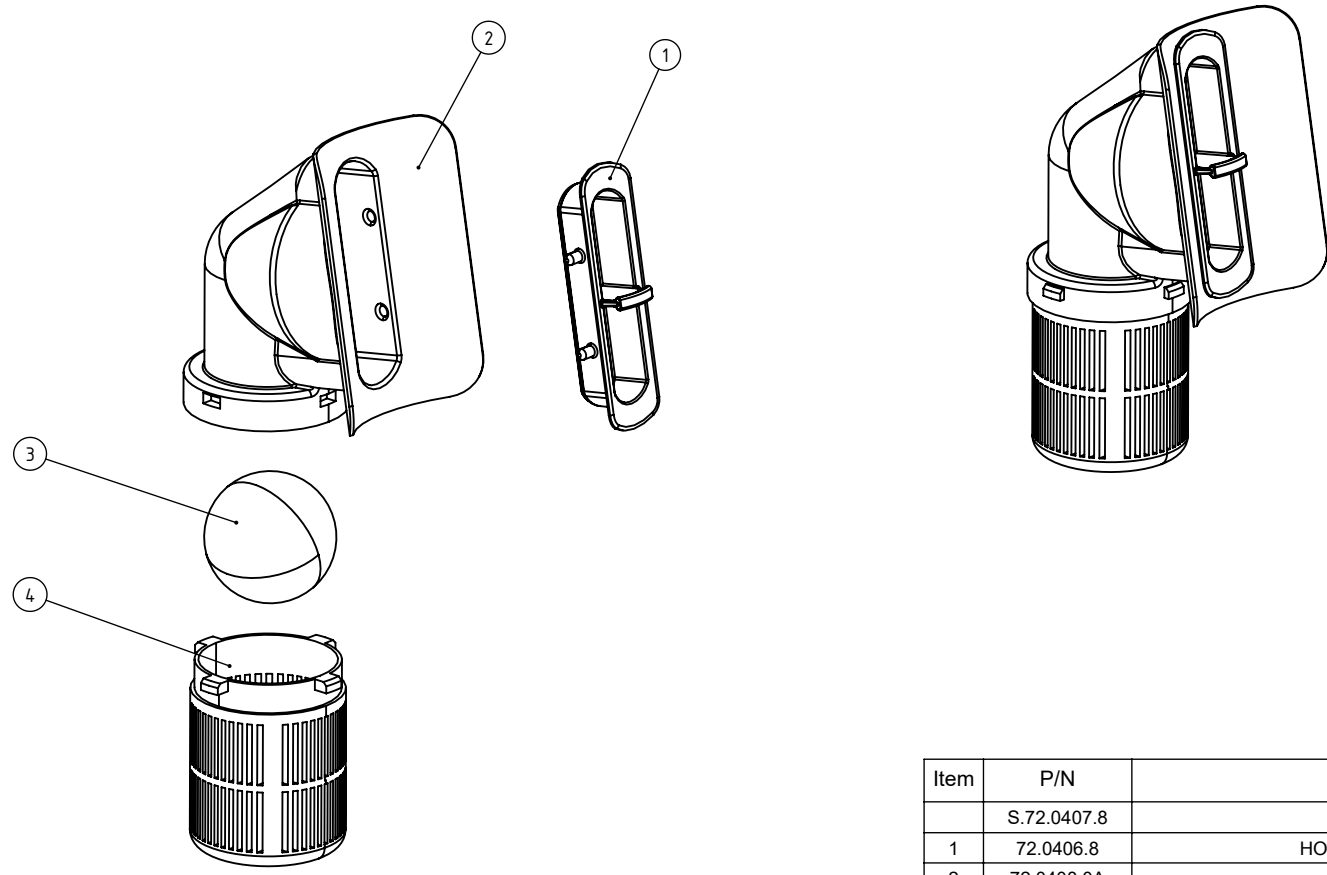

Item	P/N	Description	Qty.
	S.72.0407.8	ASSY FLOAT BALL	
1	72.0406.8	HOUSING SUPPORT YELLOW P122C	1
2	72.0408.0A	FLOAT BALL HOUSING	1
3	72.0407.0A	FLOAT BALL 35MM	1
4	72.0405.8A	FLOAT BALL CAGE YELLOW P122C	

TOLERANCES UNSPECIFIED		REMARK: -		SMT-FCT DONGGUAN THE FRIENDLY FAMILY 东莞硕能塑胶模具有限公司 ASSEMBLY AND MOULDING OF CLEANING			
LINE	ANGLE	MATERIAL: -					
.xxx ±0.005	x ±2°	APPROVED	CHECKED	DISGNE	REV.	A	PART NAME
.xx ±0.05	.x ±1.5°			CONNIE	UNIT	mm	IMOPXXLN.FCT.7 EXPLODED VIEW
.x ±0.1	.xx ±1°				SCALE		PART NO
. ±0.2	.xxx ±0.5°						IMOPXXLN.FCT.7
xx ±0.5							PROJECT
xxx ±1							SIZE
SHEET OF		DATE		29/Aug/2019		A4	

Revision	Description		Revised	Date	PAGE	6 / 21
A	FIRST RELEASE		CONNIE	29/Aug/2019		

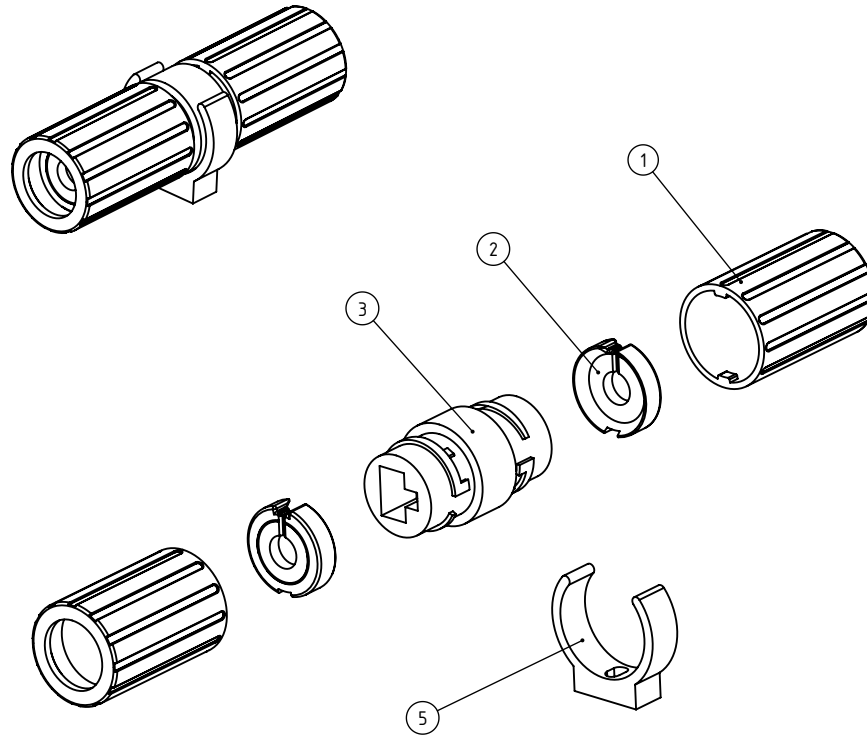

Item	P/N	Description	Qty.
	S.72.0243.0	ASSEMBLY SIGAR UTP CONNECTOR	1
1	72.0244.797/A	COVER UTP CONNECTOR JOINT COLOR: BLUE (P312C) (A)	2
2	72.0245.797	SUPPORT PLATE SIGAR UTP CONNECTOR COLOR: BLUE (P312C)	2
3	72.0243.0	SIGAR UTP CONNECTOR	1
4	72.0240.0	COUNT SUNK SCREW M3.5X13 PHILPS HEAD	1
5	72.0247.0/A	CLIP PLASTIC IN WHIRE WIDTH: 7mm	1

TOLERANCES UNSPECIFIED		REMARK: -		SMT-FCT DONGGUAN THE FRIENDLY FAMILY 东莞硕能塑胶模具有限公司 ASSEMBLY AND MOULDING OF CLEANING					
LINE	ANGLE	MATERIAL: -							
.xxx ±0.005	x ±2°	APPROVED	CHECKED	DISGNE	REV.	A	PART NAME	IMOPXLN.FCT.7 EXPLODED VIEW	FIRST ANGLE PROJECTION
.xx ±0.05	.x ±1.5°			CONNIE	UNIT	mm	PART NO	IMOPXLN.FCT.7	SIZE
.x ±0.1	.xx ±1°				SCALE		PROJECT		A4
. ±0.2	.xxx ±0.5°								
xx ±0.5									
xxx ±1									
SHEET OF	DATE			29/Aug/2019					

1		2		3		4		5		6	
Revision	Description			Revised	Date						
A	FIRST RELEASE			CONNIE	29/Aug/2019						
										PAGE	7 / 21

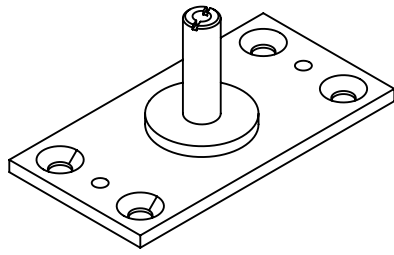
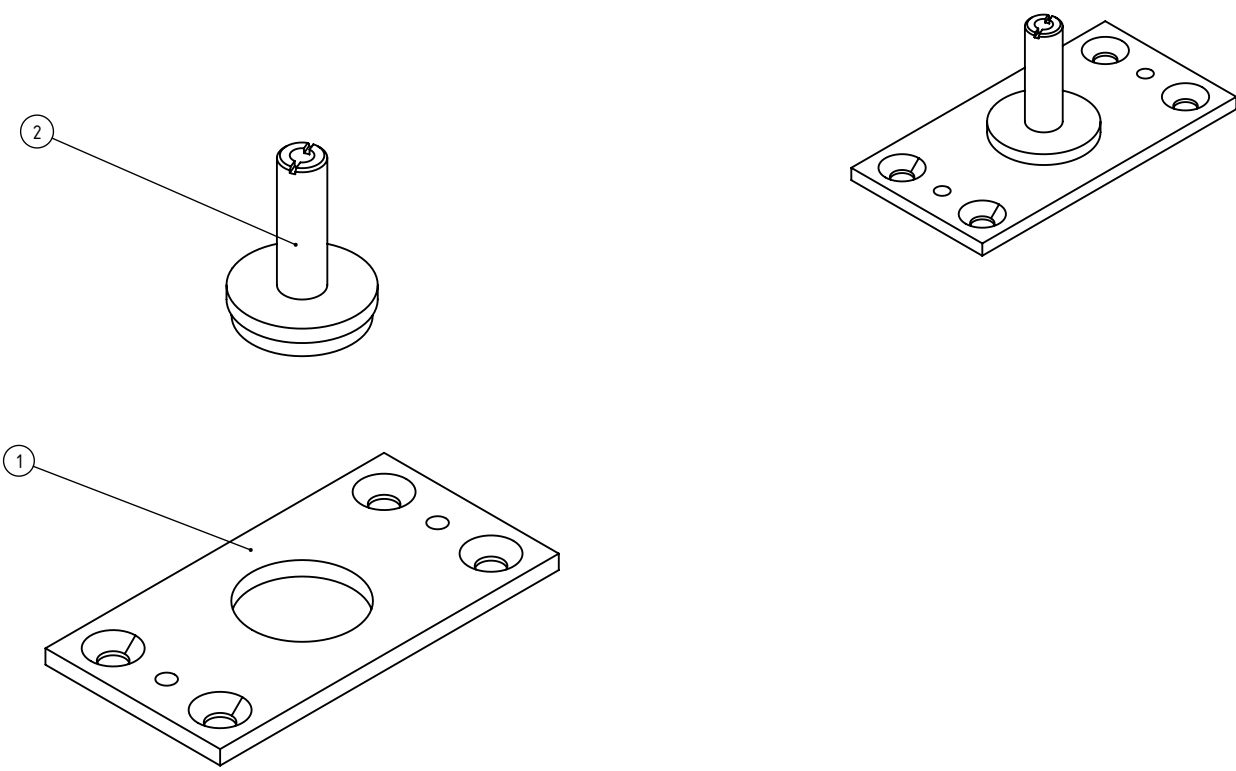

Item	P/N	Description	Qty.
	S.72.0031.2A	HING WEKDUBG ASSY TOP UNIT	
1	72.0031.1	HINGE CONSTRUCTION PLATE TOP UNIT	1
2	72.0032.0	HINGE AXIS TOP UNIT [MCH 1416-1001-2027]	1

TOLERANCES UNSPECIFIED		REMARK: -		SMT-FCT DONGGUAN THE FRIENDLY FAMILY 东莞硕能塑胶模具有限公司 ASSEMBLY AND MOULDING OF CLEANING					
LINE	ANGLE	MATERIAL: -							
.xxx ±0.005	x ±2°	APPROVED	CHECKED	DISGNE	REV.	A	PART NAME	IMOPXXLN.FCT.7 EXPLODED VIEW	
.xx ±0.05	.x ±1.5°			CONNIE	UNIT	mm	PART NO	IMOPXXLN.FCT.7	SIZE
.x ±0.1	.xx ±1°						PROJECT		A4
. ±0.2	.xxx ±0.5°								
xx ±0.5									
xxx ±1									
SHEET 1 OF 1		DATE				29/Aug/2019	SCALE		

1		2		3		4		5		6	
Revision	Description			Revised	Date						
A	FIRST RELEASE			CONNIE	29/Aug/2019						
										PAGE	8 / 21

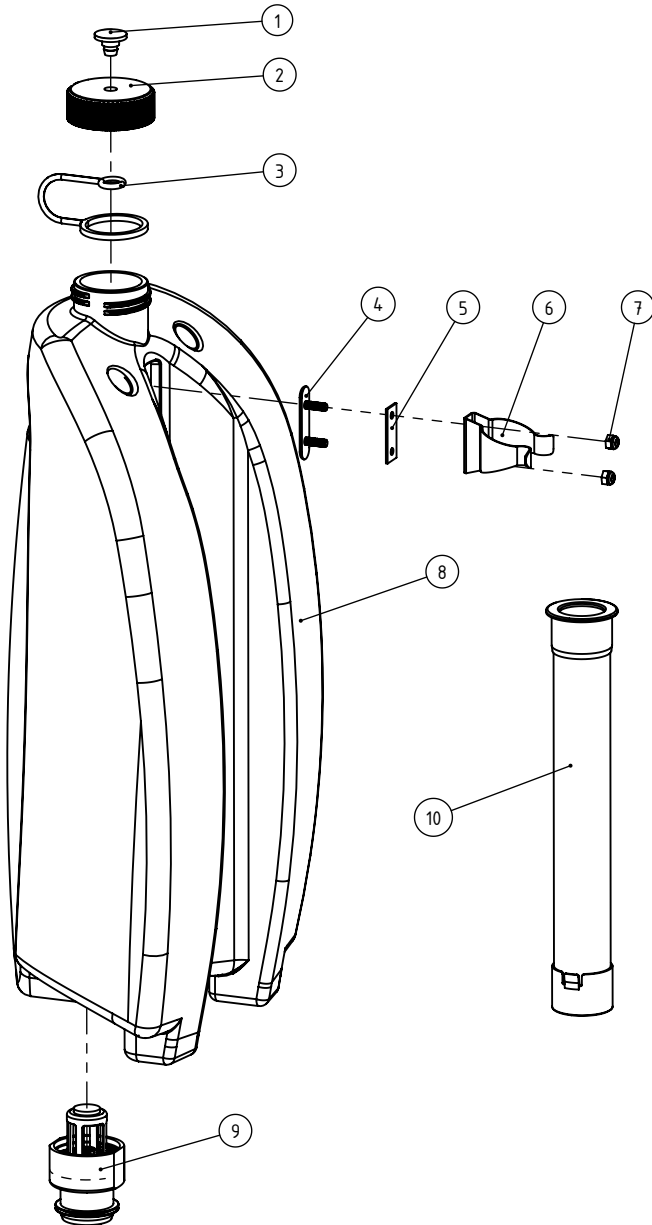

Item	P/N	Description	Qty.
	S.72.1081.0A	ASSY CLEAN COMPARTMENT XXL COMPLETE	
1	72.0254.1	SLEEVE CAP HOLDER CLEAN TANK	1
2	72.0251.797	CAP WITH HOLE, BLEUR: BLUE .797 (P312C)	1
3	72.0252.0	CAP HOLDER	1
4	72.0253.0	HOLDER PLATE CLIP CLEAN TANK	1
5	72.0290.0	RUBBER CUSHION FOR METAL CLIP	1
6	72.0288.0	METAL CLIP CLEAN TANK	1
7	72.0261.0	NUT M4 NYLON STAINLESS	2
8	72.1081.0	CLEAN COMPARTMENT XXL	1
9	S.72.0085.357	WATER COUPLING VERSION	1
10	S.72.0250.0	ASS FILLING HOSE FOR IMOP 30CM	1

TOLERANCES UNSPECIFIED		REMARK: -		SMT-FCT DONGGUAN THE FRIENDLY FAMILY 东莞硕能塑胶模具有限公司 ASSEMBLY AND MOULDING OF CLEANING					
LINE	ANGLE	-						MATERIAL: -	
.xxx ±0.005	x ±2°	APPROVED	CHECKED	DISGNE	REV.	A	PART NAME	IMOPXXLN.FCT.7 EXPLODED VIEW	
.xx ±0.05	.x ±1.5°			CONNIE	UNIT	mm	PART NO	IMOPXXLN.FCT.7	
.x ±0.1	.xx ±1°	SHEET OF		DATE		29/Aug/2019	SCALE	PROJECT	SIZE
. ±0.2	.xxx ±0.5°								A4
xx ±0.5									
xxx ±1									

1		2		3		4		5		6	
Revision	Description			Revised	Date						
A	FIRST RELEASE			CONNIE	29/Aug/2019						
										PAGE	9 / 21

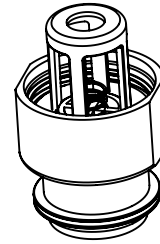
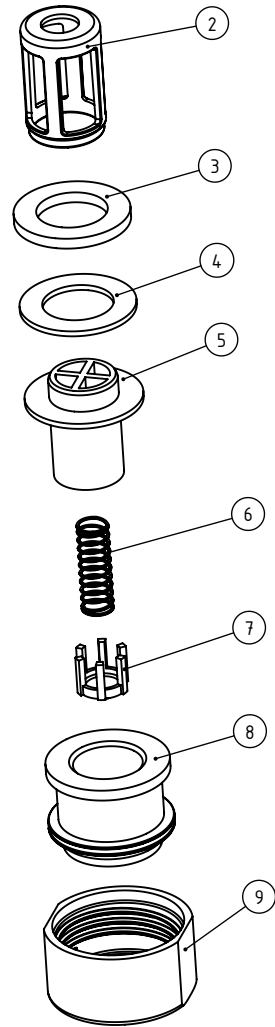

Item	P/N	Description	Qty.
	S.72.0085.357	WATER COUPLING VERSION	
1	72.0192.6	RUBBER BLOCK FILTER	1
2	72.0085.0	WATER COUPLING FILTER	1
3	72.0192.5	RUBBER GASKET ID 19mm, OD31mm, T=1.5mm	1
4	72.0192.5/A	RUBBER GASKET ID 19mm, OD31mm, T=3mm	1
5	72.0192.2/375A	HOUSING OF VALVE	1
6	72.0192.3/A	SPRINGWATER COUPLING (A)	1
7	72.0192.4/357A	VALVE WATER COUPLING, GREY (A)	1
8	72.0192.1	HOUSING WATER COUPLING	1
9	72.0289.0/8	METAL CAP WATER COUPLING, YELLOW	1

TOLERANCES UNSPECIFIED		REMARK: -		SMT-FCT DONGGUAN THE FRIENDLY FAMILY 东莞硕能塑胶模具有限公司 ASSEMBLY AND MOULDING OF CLEANING			
LINE	ANGLE	-					
.xxx ±0.005	x ±2°	-		APPROVED	CHECKED	DISGND	REV.
.xx ±0.05	.x ±1.5°	-				CONNIE	UNIT
.x ±0.1	.xx ±1°	-					mm
. ±0.2	.xxx ±0.5°	-					PROJECT
xx ±0.5		-					SCALE
xxx ±1		-					DATE
SHEET OF		DATE				29/Aug/2019	

Revision	Description	Revised	Date
A	FIRST RELEASE	CONNIE	29/Aug/2019

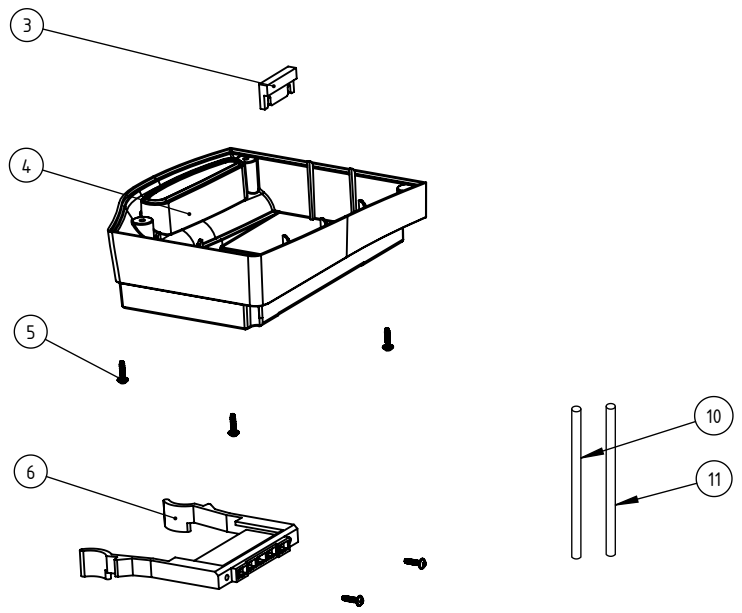
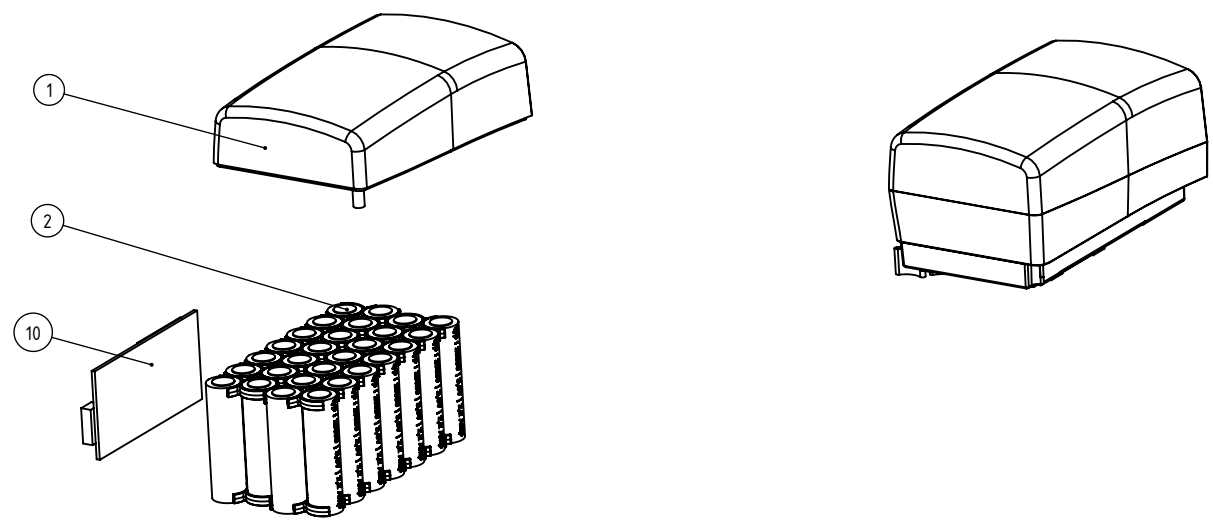

Item	P/N	Description	Qty.
	S.72.0074.2BSRA	ASSY BATTERY PACK BLUE LEFT BMS (FIRE RES) (W/O FUSE)	
1	72.0078.2R	BATTERY PACK HOUSING TOP LEFT (FIRE RESISTANT)	1
2	72.0131.1/A	BATTERY PACK CELLS WITH BMS (8.8Ah) (W/O FUSE)	1
3	72.0074.2R	BATTERY PACK HOUSING BOTTOM LEFT WHITE (FIRE RESISTANT)	1
4	72.0057.0	SCREW WN 5451 25X10 EJOT DELATA PT (MCH 1416-1001-2150)	6
5	72.0075.797	BATTERY CONNECTOR FEMALE, BLUE, LEFT (P312C)	1
6	72.0218.0	LIMITATION BLOCK FEMALE CONNECTOR	1
7	72.0170.0 NO SHOW	BUBBLE WRAP BAG 250x210	1
8	89.0469.2099.05 NO SHOW	SERIAL NO. BATTERY (C)	1
9	89.0469.2099.06BM NO SHOW	STICKER SAFETY ADVISE FOR BATTERY LEFT BMS	1
10	72.0284.0	BMS BOARD IMOP BATTERY	1
11	72.0129.0	BATTERY CONNECTOR + WIRES 14AWG, RED, L=250mm	1
12	72.1030.0	BATTERY CONNECTOR + WIRES 14AWG, BLACK, L=250mm	1

TOLERANCES UNSPECIFIED		REMARK: -		SMT-FCT_DONGGUAN THE FRIENDLY FAMILY 东莞硕能塑胶模具有限公司 ASSEMBLY AND MOULDING OF CLEANING						
LINE	ANGLE	-						MATERIAL: -		
.xxx ±0.005	x ±2°	APPROVED	CHECKED	DISGNE	REV.	A	PART NAME	IMOPXXLN.FCT.7 EXPLODED VIEW		
.xx ±0.05	.x ±1.5°			CONNIE	UNIT	mm	PART NO	IMOPXXLN.FCT.7		
.x ±0.1	.xx ±1°				SCALE	1:1	PROJECT		SIZE	A4
. ±0.2	.xxx ±0.5°									
xx ±0.5										
xxx ±1										
SHEET OF	DATE			29/Aug/2019						

1	2		3		4		5		6	
Revision	Description		Revised	Date					PAGE	11 / 21
A	FIRST RELEASE		CONNIE	29/Aug/2019						

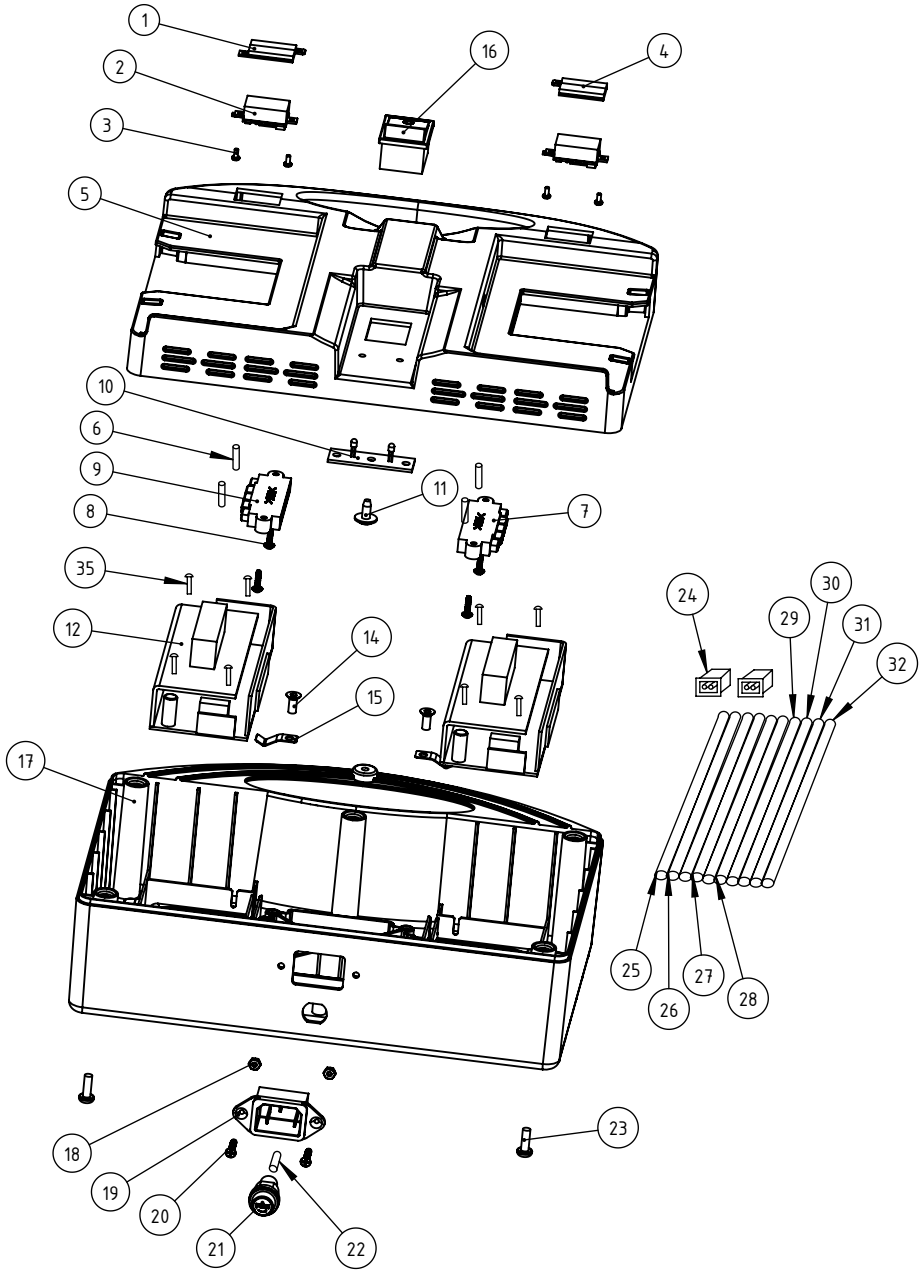

Item	P/N	Description	Qty.
	S.72.0299.B/1	IMOP BATTERY MCU CHARGER 3 PIN	
1	72.0275.1	TRANSPARENT COVER VOLTAGE DISPLAY RIGHT	1
2	72.0174.0/A	VOLTAGE DISPLAY WITH PERCENTAGE	2
3	72.0328.0	SCREW M2X 5 CROSS HEAD SELF TAPPING	4
4	72.0275.0	TRANSPARENT COVER VOLTAGE DISPLAY LEFT	1
5	72.0187.2R	NEW CHARGER TOP HOUSING WHITE [FIRE RESISTANT]	1
6	85.0050.1	ALIGNMENT PIN LONGER VERSION	4
7	72.0068.357	BATTERY CONNECTOR MALE, LEFT: GREY	1
8	72.0057.0	SCREW WN 5451 25X10 EJOT DELTA PT [MCH 1416-1001-2150]	4
9	72.0068.797	BATTERY CONNECTOR MALE, Right: BLUE	1
10	72.0197.0	LED PCB NEW CHARGER IMOP	1
11	85.1035.0	SCREW M3 X 10 CROSS HEAD WASHER SELF TAPPING BL-NI	1
12	72.0106.0/A	CHARGE UNIT MCU	2
13	72.0060.2	POWER SWITCH CONTROL UNIT OMORON	1
14	00.0002.7	SCREW 4 X 10	3
15	72.0205.0	WIRE CLAMP	2
16	04.0009.30	SWITCH 4P LIGHT GREEN 0/I	1
17	72.0188.357R	NEW CHARGER TOP BOTTOM HOUSING GREY [FIRE RESISTANT]	1
18	20.0031.5	NUT M3 NYLON	2
19	72.0002.3	RECEPT INLET 3P+TWO SCREW HOLES CB 3PIN	1
20	66.0301.0	COUNTER SUNK SCREW M3*15	2
21	72.0195.0	FUSE BASE 6.3A	1
22	72.0195.1	FUSE 6.3A	1
23	00.0121.0	SCREW ST4 X 9.3 CROSSHEAD SELFTAPED BL-NI	6
24	72.0124.1	HOUSING VH-2P	2
25	72.0193.4	WIRE RED INLET TO SWITCH	1
26	72.0123.0/A	MALE CONNECTOR + WIRES 18AWG BLACK 270M	2
27	72.0124./0A	MALE CONNECTOR + CONNECTOR WIRES 18AWG BLACK 270MM	2
28	72.0144.0	2 CORD WIRE WITH CONNECTOR PCB	2
29	72.0193.0/A	WIRE BLACK/RED WITH TUBE CHARGER SWITCH	1
30	72.0193.2	WIRE BLACK INLET TO FUSE	1
31	72.0193.3	WIRE BLACK FUSE TO SWITCH	1
32	72.0193.5	GROUND WIRE YELLOW & GREEN	1
33	89.0469.2089.00 NO SHOW	SERIAL NO. BATTERY MCU CHARGER	1
34	72.0326.0 NO SHOW	CABLE TIE 3*130MM	1
35	72.0325.0	COUNTER SINK SELF TAP SCREW M3.6X15	8

TOLERANCES UNSPECIFIED		REMARK:		SMT-FCT DONGGUAN THE FRIENDLY FAMILY 东莞硕能塑胶模具有限公司 ASSEMBLY AND MOULDING OF CLEANING			
LINE	ANGLE	-					
.xxx ±0.005	x ±2°	MATERIAL: -		APPROVED	CHECKED	DISGNE	REV.
.xx ±0.05	.x ±1.5°					CONNIE	A
.x ±0.1	.xx ±1°					UNIT	mm
. ±0.2	.xxx ±0.5°					SCALE	PROJECT
xx ±0.5						DATE	29/Aug/2019
xxx ±1							A4

1	2		3		4		5		6	
Revision	Description		Revised	Date						
A	FIRST RELEASE		CONNIE	29/Aug/2019						
				PAGE		12 / 21				

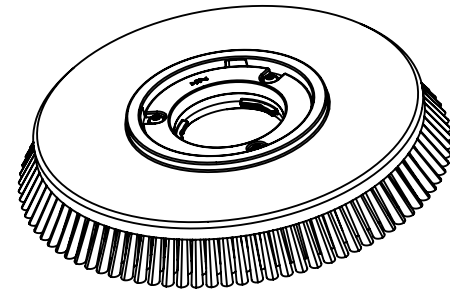
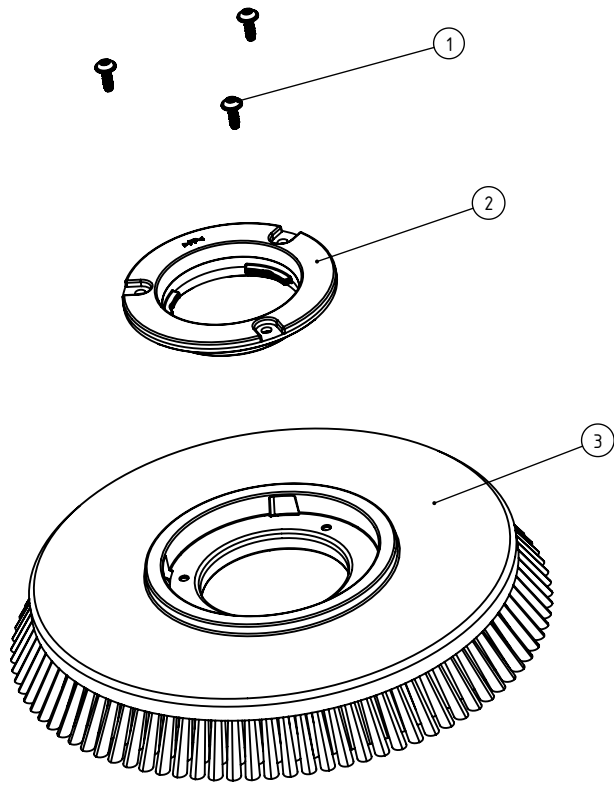

Item	P/N	Description	Qty.
	S.72.1092.797/797	ASS BRUSH IMOPXXL COMPLETE BLUE BRISTLE, BLUE LOCKER	
1	72.0026.0	SCREW WN 5451 50X14 EJOT DELTA PT (MCH 1416-1001-2004)	3
2	72.0093.797	BRUSH LOCKER BLUE (P312C)	1
3	S.72.1091.797	ASSY BRUSH DISC BLUE [P312C] XXL	1

TOLERANCES UNSPECIFIED		REMARK:		<p style="text-align: center;">SMT-FCT DONGGUAN THE FRIENDLY FAMILY 东莞硕能塑胶模具有限公司 ASSEMBLY AND MOULDING OF CLEANING</p>							
LINE	ANGLE	-									
.xxx ±0.005	x ±2°	MATERIAL: -		APPROVED	CHECKED	DISGNE	REV.	A	PART NAME	IMOPXXLN.FCT.7 EXPLODED VIEW	SIZE
.xx ±0.05	.x ±1.5°					CONNIE	UNIT	mm	PART NO	IMOPXXLN.FCT.7	
.x ±0.1	.xx ±1°						SCALE		PROJECT		A4
. ±0.2	.xxx ±0.5°										
xx ±0.5											
xxx ±1											
SHEET OF		DATE				29/Aug/2019					

1	2		3		4		5		6	
Revision	Description		Revised	Date					PAGE	13 / 21
A	FIRST RELEASE		CONNIE	29/Aug/2019						

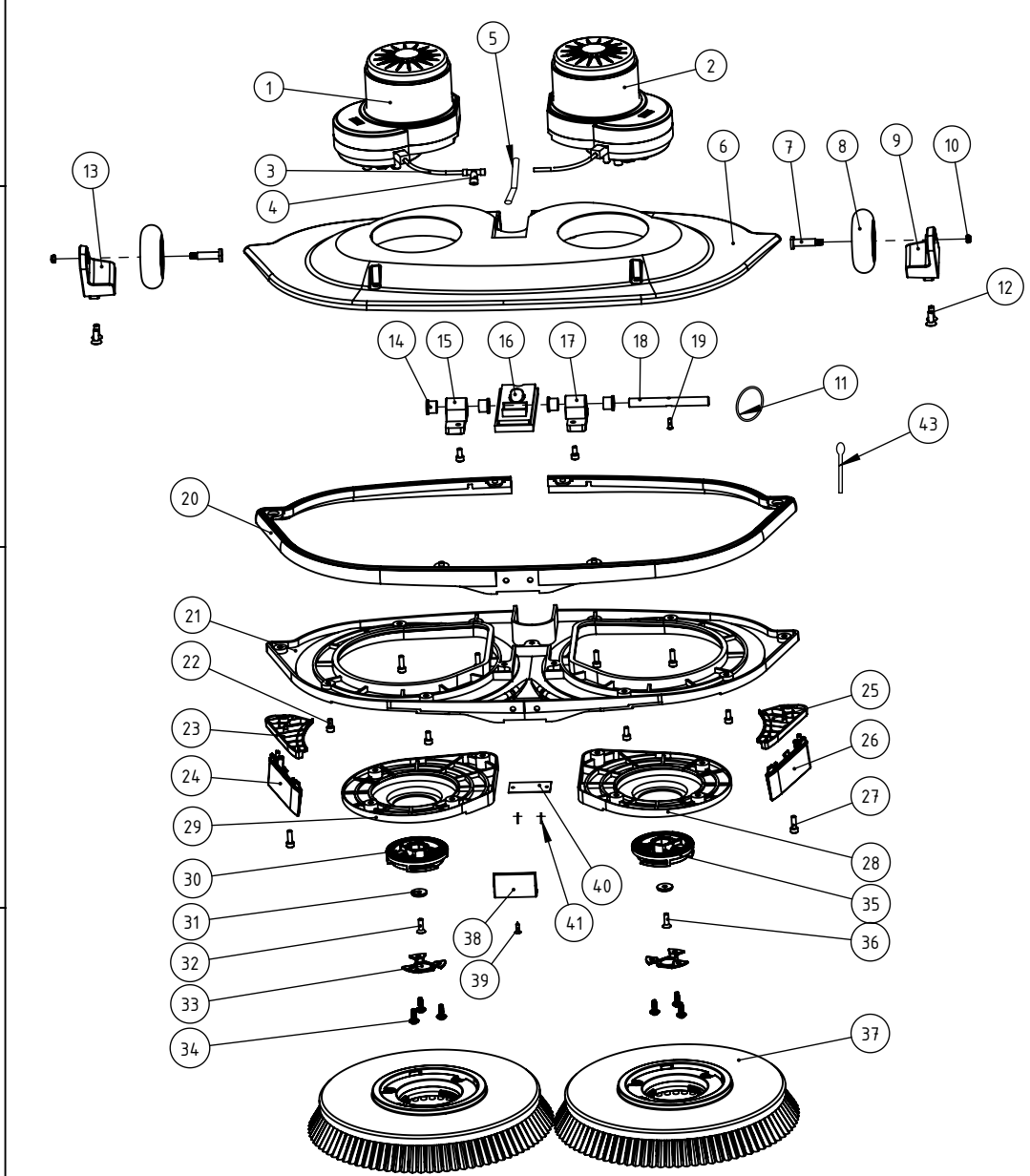

Item	P/N	Description	Qty.
	BU.IMOPXXL.230.36	ASSY BRUSH UNIT IMOPXXL 24V SILVER	
1	S.72.0000.1R	ASSY BRUSH MOTOR RIGHT	1
2	S.72.0000.0R	ASSY BRUSH MOTOR LEFT	1
3	72.0022.1	WATER CHANNEL DIA.4MM L:150mm [MCH 1416-1001-2109]	2
4	72.0109.0	WATER COUPLING BRUSH MOTOR	1
5	72.0022.0	WATER CHANNEL DIA.6MM L:570mm [MCH 1416-1001-2034]	1
6	72.1008.0	BRUSH MOTOR CONSTRUCTION COVER XXL	1
7	72.0027.3C	SHAFT TRANSPORT CASTOR [V3]	2
8	72.0029.2/797	[MCH211-264] (101) WHITE CASTOR + BLUE BRACKET	2
9	72.1009.0	PILLAR CASTOR XXL LEFT	1
10	04.0048.0	NUT M5 NYLON	2
11	89.0469.2099.24	REMOVE STICKER ON THE SWITCH	2
12	72.0002.0N	NYLOK SCREW COUNTER SUNK BOLT M6X16 [MCH 1416-1001-2104]	4
13	72.1009.1	TRANSPORT WHEEL PILLAR RIGHT LONG [NEW]	1
14	72.0016.0	BRUSHING AXIS 10 [MCH 1416-1001-2112]	4
15	72.0015.1	BRUSH UNIT HINGE SUPPORT RIGHT [MCH 1416-1001-2186]	1
16	72.0021.0	CONSTRUCTION COVER SEAL [MCH 1416-1001-2115]	1
17	72.0015.0	BRUSH UNIT HINGE SUPPORT LEFT [MCH 1416-1001-2185]	1
18	72.0013.0A	CHASSIS HINGE BELT HOLE	1
19	72.0014.0N	NYLOK SCREW COUNTER SUNK BOLT M4x12	1
20	72.1023.0	BRUSH UNIT PROTECTOR XXL	1
21	72.1110.357A	COVER, BRUSH, BOTTOM [XXL]	1
22	72.0017.0N	NYLOK SOCKET HEAD CAP SCREW M5X10	27
23	72.1401.0	SPLASHING GUARD BOTOM LEFT XXL	1
24	72.0401.1	TRANSPARENT SPLASHING GUARD LEFT	1
25	72.1402.0	SPLASHING GUARD BOTOM RIGHT XXL	1
26	72.0402.1	TRANSPARENT SPLASHING GUARD RIGHT	1
27	72.0260.0	NYLOK HEXAGON SOCKET HEAD CAP SCREWS M5X20 SST	2
28	72.0320.0	BRUSH MOTOR FIXATION PLATE RIGHT XXL	1
29	72.0319.0	BRUSH MOTOR FIXATION PLATE LEFT XXL	1
30	72.0024.0/357	DRIVING WHEEL BOTTOM LEFT Color: Grey [P431C]	1
31	72.0025.1	SUPPORT DISC DRIVING WHEEL SIDE ,HOLE DIA.5MM	2
32	72.0014.3N/1	NYLOK SCREW COUNTER SUNK BOLT M5X18.5	1
33	72.0312.797	COVER BRUSH MOTOR SCREW, Kleur: Blue .797 (P312C)	2
34	72.0026.0	SCREW WN 5451 50X14 EJOT DELTA PT	6
35	72.0024.1/357	DRIVING WHEEL BOTTOM RIGHT Color: Grey [P431C]	1
36	72.0014.4N/1	NYLOK SCREW COUNTER SUNK BOLT M5X18.5[REVERSE THREAD BLACK]	1
37	S.72.1092.797/797	ASS BRUSH IMOPXXL COMPLETE BLUE BRISTLE BLUE LOCKER	2
38	72.0318.0M	REPLACABLE BUMPER PIECE TOOLING AMORTIZED 2000	1
39	109.0083.0	SCREW ST3 X 5_Y_SLOT_FT_SU304	1
40	89.04673.2099.04C	METAL PLATE IMOPXXL THICKNESS:0.5MM ELECTROPHORESIS	1
41	02.0005.10	BLIND RIVET 3 x 6	2
42	57.0076.0 NO SHOW	BLACK CABLE TIE 3 X 15 BLACK	1
43	72.0394.0	IMOP PEDESTAL SHAFT PIN	2

TOLERANCES UNSPECIFIED		REMARK:		<p style="text-align: center;">SMT-FCT_DONGGUAN THE FRIENDLY FAMILY 东莞硕能塑胶模具有限公司 ASSEMBLY AND MOULDING OF CLEANING</p>			
LINE	ANGLE	-					
.xxx ±0.005	x ±2°	MATERIAL: -		APPROVED	CHECKED	DISGNED	REV.
.xx ±0.05	.x ±1.5°					CONNIE	A
.x ±0.1	.xx ±1°						mm
. ±0.2	.xxx ±0.5°						UNIT
xx ±0.5							SCALE
xxx ±1							PROJECT
SHEET 1 OF 1		DATE		29/Aug/2019		A4	

1	2		3		4		5		6	
Revision	Description		Revised	Date						
A	FIRST RELEASE		CONNIE	29/Aug/2019	PAGE 14 / 21					

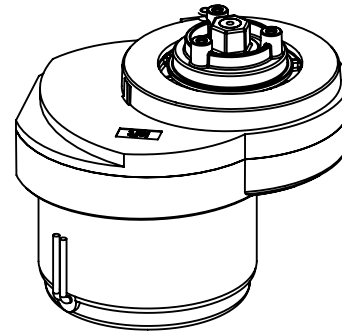
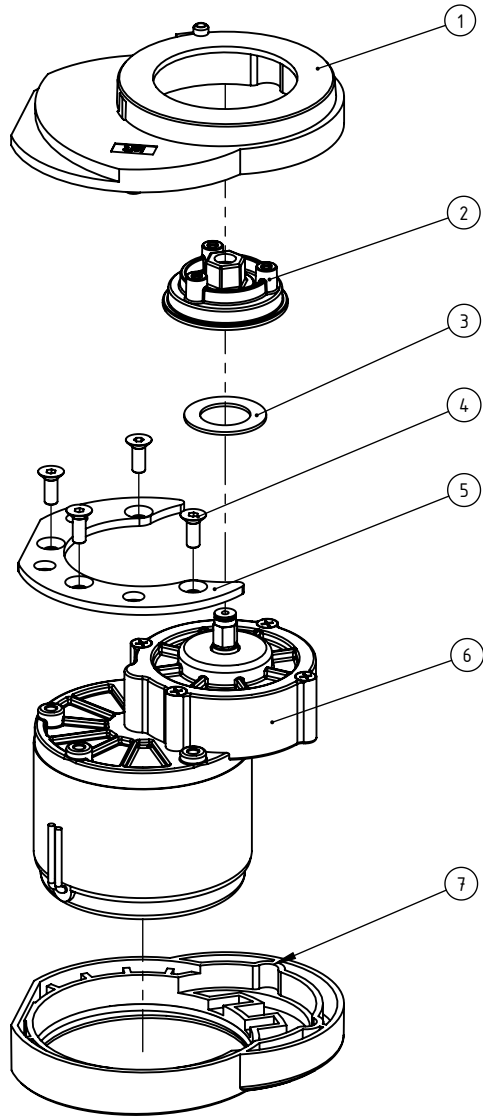

Item	P/N	Description	Qty.
	S.72.0000.0R	ASSY BRUSH MOTOR LEFT (Ve1)	
1	72.0007.0	BRUSH MOTOR SUPPORT SUPPORT RUBBER LEFT (MCH 1416-1001-2107)	1
2	72.0005.357/C	DRIVING WHEEL TOP WITH METAL INSERT (VER.1)	1
3	72.0004.0	FELT BRUSH MOTOR (MCH 1416-1001-2183)	1
4	72.0002.0N	NYLOK SCREW COUNTER SUNK BOLT M6X16 (MCH 1416-1001-2104)	4
5	72.0001.0	BRUSH MOTOR CONSTRUCTION RING LEFT (MCH 1416-1001-2106)	1
6	72.0000.0MR	BRUSH MOTOR HELICAL GEARS LEFT (MCH 1416-1001-2105)	1
7	72.0006.0/A	BRUSH MOTOR FIXATION CONDUCTIVE RUBBER LEFT	1
8	72.0108.0 NO SHOW	LOCKTITE 222	0.02
9	89.0469.2099.00 NO SHOW	SERTAL NO. BRUSH MOTOR LEFT	1

TOLERANCES UNSPECIFIED		REMARK:		SMT-FCT DONGGUAN THE FRIENDLY FAMILY 东莞硕能塑胶模具有限公司 ASSEMBLY AND MOULDING OF CLEANING							
LINE	ANGLE	-									
.xxx ±0.005	x ±2°	MATERIAL: -		APPROVED	CHECKED	DISGNE	REV.	A	PART NAME	IMOPXXLN.FCT.7 EXPLODED VIEW	
.xx ±0.05	.x ±1.5°					CONNIE	UNIT	mm	PART NO	IMOPXXLN.FCT.7	SIZE
.x ±0.1	.xx ±1°						SCALE		PROJECT		A4
. ±0.2	.xxx ±0.5°										
xx ±0.5											
xxx ±1											
SHEET OF	DATE										

1		2		3		4		5		6	
Revision	Description			Revised	Date						
A	FIRST RELEASE			CONNIE	29/Aug/2019						
										PAGE	15 / 21

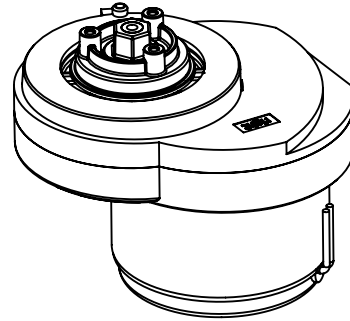
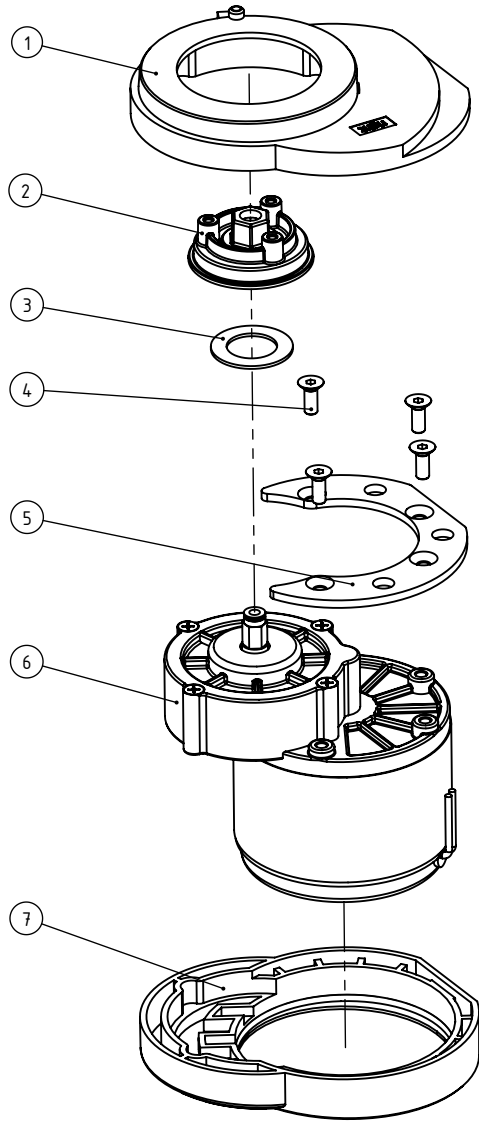

Item	P/N	Description	Qty.
	S.72.0000.1R	ASSY BRUSH MOTOR RIGHT (Ver1)	
1	72.0007.1	BRUSH MOTOR SUPPORT SUPPORT RUBBER RIGHT (MCH 1416-1001-2101)	1
2	72.0005.357/C	DRIVING WHEEL TOP WITH METAL INSERT (VER.1)	1
3	72.0004.0	FELT BRUSH MOTOR (MCH 1416-1001-2183)	1
4	72.0002.0N	NYLOK SCREW COUNTER SUNK BOLT M6X16 (MCH 1416-1001-2104)	4
5	72.0001.1	BRUSH MOTOR CONSTRUCTION RING RIGHT (MCH 1416-1001-2007)	1
6	72.0000.1MR	BRUSH MOTOR HELICAL GEARS RIGHT (MCH 1416-1001-2005)	1
7	72.0006.1/A	BRUSH MOTOR FIXATION CONDUCTIVE RUBBER RIGHT	1
8	72.0108.0 NO SHOW	LOCKTITE 222	0.02
9	89.0469.2099.01 NO SHOW	SERTAL NO. BRUSH MOTOR RIGHT	1

TOLERANCES UNSPECIFIED

LINE	ANGLE		
.xxx	±0.005	x	±2°
.xx	±0.05	.x	±1.5°
.x	±0.1	.xx	±1°
.	±0.2	.xxx	±0.5°
xx	±0.5		
xxx	±1		

REMARK: -

MATERIAL: -

APPROVED	CHECKED	DISGNE	REV.	A	PART NAME	IMOPXXLN.FCT.7 EXPLODED VIEW	FIRST ANGLE PROJECTION
		CONNIE	UNIT	mm	PART NO	IMOPXXLN.FCT.7	SIZE
SHEET OF	DATE	29/Aug/2019	SCALE		PROJECT		A4

SMT-FCT DONGGUAN
THE FRIENDLY FAMILY
 东莞硕能塑胶模具有限公司
ASSEMBLY AND MOULDING OF CLEANING

1	2		3		4		5		6	
Revision	Description		Revised	Date						
A	FIRST RELEASE		CONNIE	29/Aug/2019	PAGE 16 / 21					

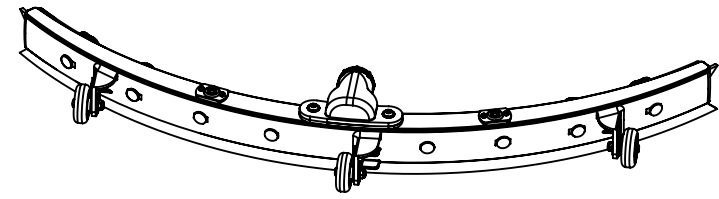
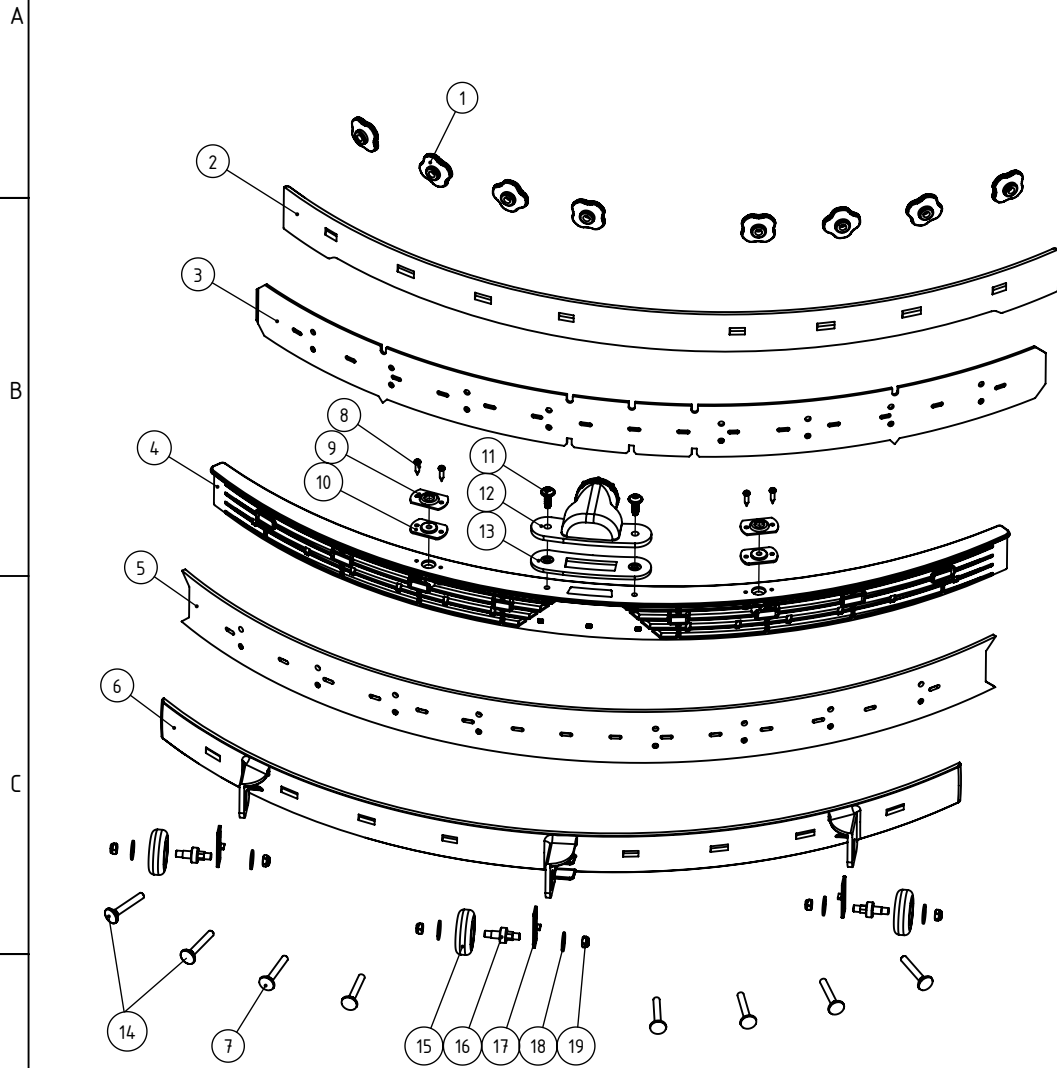

Item	P/N	Description	Qty.
	S.72.1096.2	SQUEEGEE ASSEMBLY XXL	
1	72.0135.0	PLASTIC NUT SQUEEGEE	8
2	72.1097.0	SQUEEGEE REAR PLATE XXL	1
3	72.1099.2A	SQUEEGEE FRONT RUBBER XXL LINATEX MATERIAL NAT COLOR RED	1
4	72.1098.0	SQUEEGEE TOP PLATE XXL	1
5	72.1100.2A	SQUEEGEE XXL REAR RUBBER LINATEX MATERIAL NAT COLO RED	1
6	72.1096.0	SQUEEGEE REAR PLATE XXL	1
7	72.0136.0	M5 SCREW BOLT, THREAD LENGTH 35	4
8	85.1008.1	SCREW M3 X12 CROSSHEAD SELFTAPPING BL-NI,SST	4
9	72.0340.0A	FIXATION PLATE SQUEEGEE PIN STAINLESS STEEL	2
10	72.0200.0/D	RUBBER WASHER FIXATION SQUEEGEE PIN BLACK Thickness:2.5MM	2
11	72.0026.0	SCREW WN 5451 5.0X14 EJOT DELTA PT	2
12	72.0103.8/C	SQUEEGEE HOSE CONNECTOR -UP YELLOW PP[C]	1
13	72.0102.0/A	SQUEEGEE HOSE CONNECTOR-SEALING GASKET	1
14	72.0136.1	M5 SCREW BOLT, THREAD LENGTH 30	4
15	72.0238.0	SQUEEGEE CASTOR BLACK DIA.8MM RYTON R7	3
16	72.0137.2	SHAFT SQUEEGEE CASTOR DIA.8MM	3
17	72.0138.1	HEIGHT ADJUSTMENT PLATE [Ver1]	3
18	72.0235.0	M5 WASHER STAINLESS STEEL 5X15X1MM	6
19	04.0048.0	NUT M5 NYLON STAINLESS	6

TOLERANCES UNSPECIFIED		REMARK:		<p style="text-align: center;">SMT-FCT DONGGUAN THE FRIENDLY FAMILY 东莞硕能塑胶模具有限公司 ASSEMBLY AND MOULDING OF CLEANING</p>			
LINE	ANGLE	-					
.xxx ±0.005	x ±2°	MATERIAL: -		APPROVED	CHECKED	DISGNE	REV.
.xx ±0.05	.x ±1.5°					CONNIE	UNIT
.x ±0.1	.xx ±1°						mm
. ±0.2	.xxx ±0.5°						A
xx ±0.5							PART NAME
xxx ±1							IMOPXXLN.FCT.7 EXPLODED VIEW
SHEET OF		DATE				PART NO	
		29/Aug/2019		SCALE		IMOPXXLN.FCT.7	
						SIZE	
						A4	

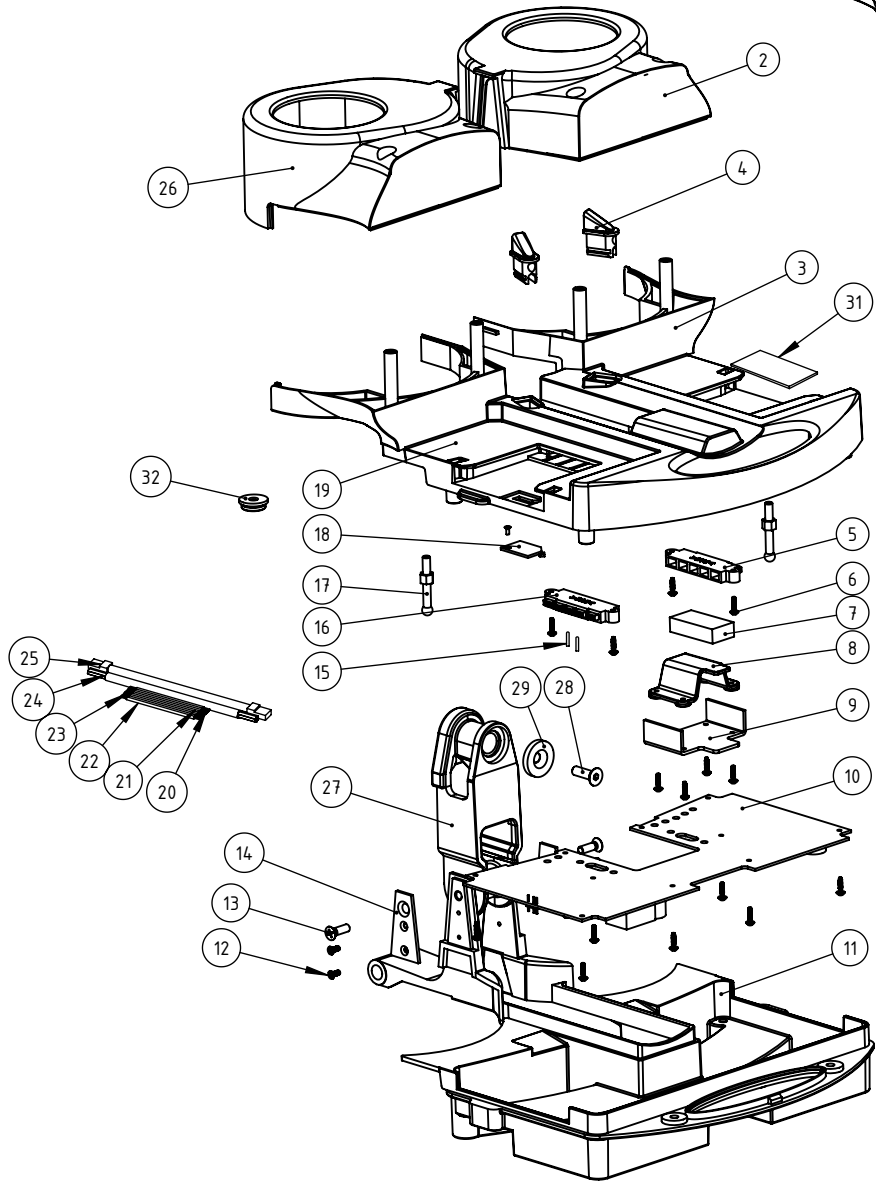
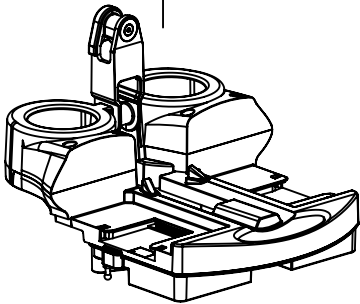

Item	P/N	Description	Qty.
	S.72.1065.21	ASSY MAIN LEVER UNIT IMOPXXL MERCURY SWITCH	
1	72.0026.0	SCREW WN 5451 50X14 EJOT DELTA PT (MCH 1416-1001-2004)	12
2	72.1072.2/A	BRUSH MOTOR COOLING COVER XXL COVER RIGHT XXL	1
3	72.1065.2A	MAIN LEVER COVER XXL, Kleur: White .2	1
4	72.0069.0A	PCB MACHINE SEAL	2
5	72.0068.357	BATTERY CONNECTOR MALE Left:Blue, Right:Grey, Kleur: Grey	1
6	72.0057.0	SCREW WN 5451 25X10 EJOT DELTA PT (MCH 1416-1001-2150)	18
7	72.0051.0	MAGNET TOP UNIT 40X20X10mm (MCH 1416-1001-2044)	1
8	72.0067.357	MAGNET TOP UNIT HOLDER (MCH 1416-1001-2192), JKEYR: GREY.357	1
9	72.0219.0	STEEL COVER ISOLATION MAGNETIC T=3mm	1
10	72.0418.0	MAIN PCB IMOP WITH CUT-OFF SWITCH	1
11	72.0010.0/A	MAIN LEVER HOUSING (A)	1
12	72.0012.1N	NYLOK COUNTER SUNK BOLT M3X8, SST	4
13	72.0028.0N	NYLOK SCREW COUNTER SUNK BOLT M5X16	2
14	72.0011.0	MAIN LEVER SUPPORT PLATE (MCH 1416-1001-2193)	2
15	85.0050.1	ALIGNMENT PIN LONGER VERSION	4
16	72.0068.797	BATTERY CONNECTOR MALE LEFT: BLUE, RIGHT: GERY, KLEUR: BLUE	1
17	72.1071.0	SQUEEGEE FIXATION PIN XXL	2
18	72.1164.2	COVER USB UPDATE SLOT, Kleur: White .2	1
19	72.0165.0	SCREW COUNTSUNK M1.7X6	1
20	72.0123.0	MALE CONNECTOR + WIRES 14AWG RED 150MM	2
21	72.0124.0	MALE CONNECTOR + CONNECTOR WIRES 14AWG BLACK 150MM	2
22	72.0157.0/A	WIRES FOR BRUSH UNIT 14AWG BLACK ANGLE TERMINAL L=280mm	2
23	72.0157.1/A	WIRES FOR BRUSH UNIT 14AWG RED ANGLE TERMINAL L=280mm	2
24	72.0126.0B	POWER CABLE 3 WIRES ANGLE TERMINALS [1.5MM 2 L=630MM]	1
25	72.0125.0F	UTP CABLE (GLASS+FIBRE) RJ45 <-> YH2.0-8P CONNECTOR L=60C	1
26	72.1073.2/A	BRUSH MOTOR COVER LEFT XXL COOLING COVER LEFT XXL	1
27	S.72.0018.0S	ASSY HINGE CARDAN ZINC ALLOY	1
28	72.0033.2	COUNTER SUNK HEAD CAP SCREW M6X20 WITH NYLOK SCREW	1
29	72.0058.1	CARDAN DISK [Ver1]	1
30	72.0222.0 NO SHOW	PET SHEET ONE SIDE 3M GLUE T=0.04MM	4
31	89.0467.2099.10	STICKER IMOP [STRONG MAGNAETS] [B]	1
32	72.0246.0	SEALING RING SIGAR UTP CONNECTOR	1

TOLERANCES UNSPECIFIED		REMARK:		SMT-FCT DONGGUAN THE FRIENDLY FAMILY 东莞硕能塑胶模具有限公司 ASSEMBLY AND MOULDING OF CLEANING			
LINE	ANGLE	-		MATERIAL: -			
.xxx ±0.005	x ±2°	APPROVED	CHECKED	DISGNE	REV.	A	PART NAME IMOPXXL.N.FCT.7 EXPLODED VIEW
.xx ±0.05	.x ±1.5°			CONNIE	UNIT	mm	PART NO IMOPXXL.N.FCT.7
.x ±0.1	.xx ±1°				SCALE		PROJECT
. ±0.2	.xxx ±0.5°						
xx ±0.5							
xxx ±1							
SHEET 1 OF 1	DATE	29/Aug/2019					A4

1	2		3		4		5		6	
Revision	Description		Revised	Date						
A	FIRST RELEASE		CONNIE	29/Aug/2019						
				PAGE		18 / 21				

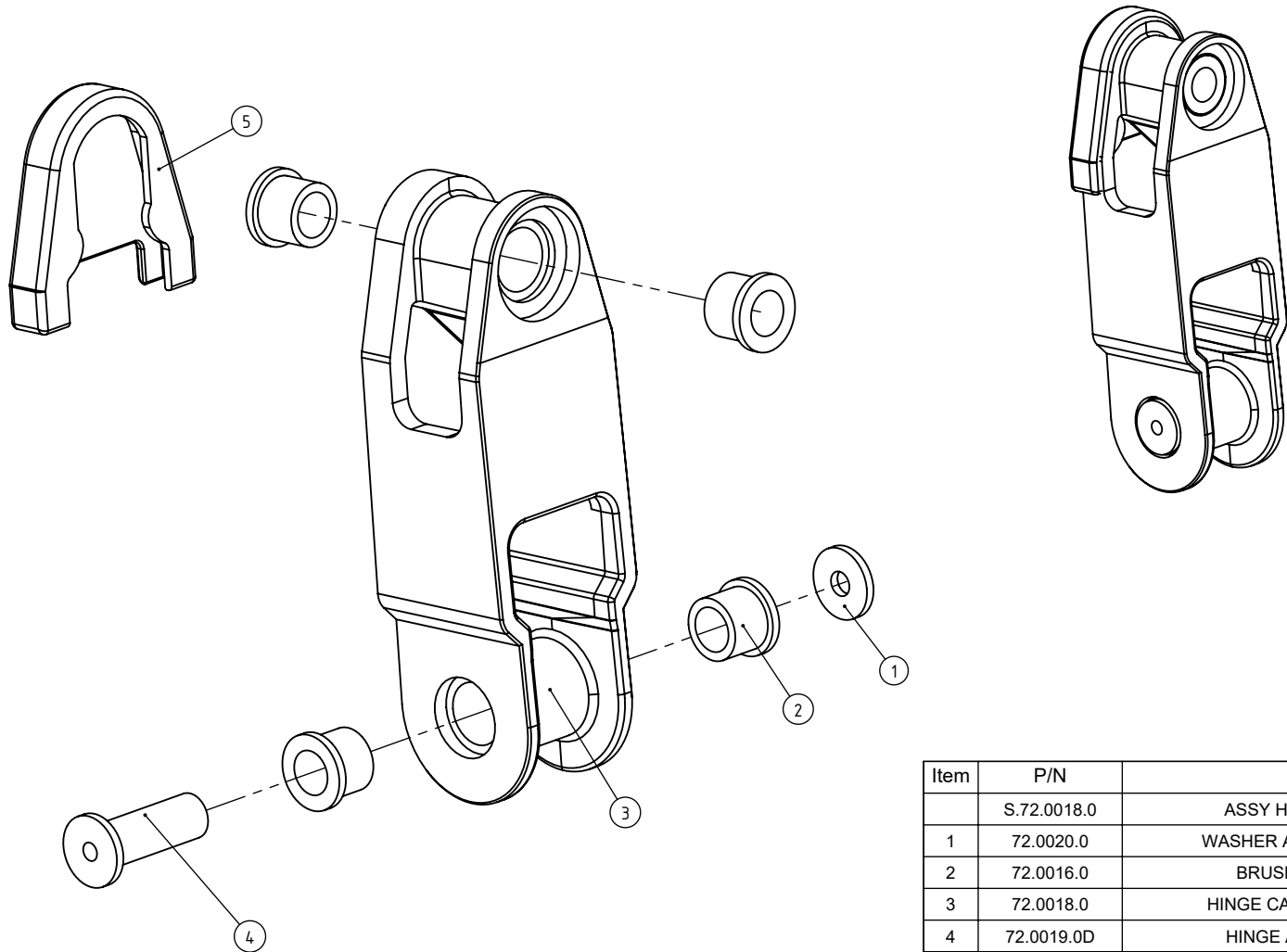

Item	P/N	Description	Qty.
	S.72.0018.0	ASSY HINGE CARDAN (MCH 1416-1001-1011)	
1	72.0020.0	WASHER AZIS MAIN LEVER (MCH 1416-1001-2116)	1
2	72.0016.0	BRUSHING AXIS 10 (MCH 1416-1001-2112)	4
3	72.0018.0	HINGE CARDAN TOP NUT (MCH 1416-1001-2029)	1
4	72.0019.0D	HINGE AXIS MAIN LEVER STAINLESS STEEL	1
5	72.0311.357	COVER HINGE SCREW, KLEUR: GREY .357 (P431C)	1

TOLERANCES UNSPECIFIED		REMARK: -		SMT-FCT DONGGUAN THE FRIENDLY FAMILY 东莞硕能塑胶模具有限公司 ASSEMBLY AND MOULDING OF CLEANING						
LINE	ANGLE	MATERIAL: -								
.xxx ±0.005	x ±2°	APPROVED	CHECKED	DISGND	REV.	A	PART NAME	IMOPXXLN.FCT.7 EXPLODED VIEW		
.xx ±0.05	.x ±1.5°			CONNIE	UNIT	mm	PART NO	IMOPXXLN.FCT.7		
.x ±0.1	.xx ±1°				SCALE	1:1	PROJECT		SIZE	A4
. ±0.2	.xxx ±0.5°	SHEET 1 OF 1		DATE		29/Aug/2019				
xx ±0.5										
xxx ±1										

1	2		3		4		5		6	
Revision	Description		Revised	Date						
A	FIRST RELEASE		CONNIE	29/Aug/2019						
				PAGE		19 / 21				

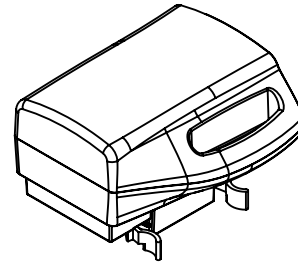
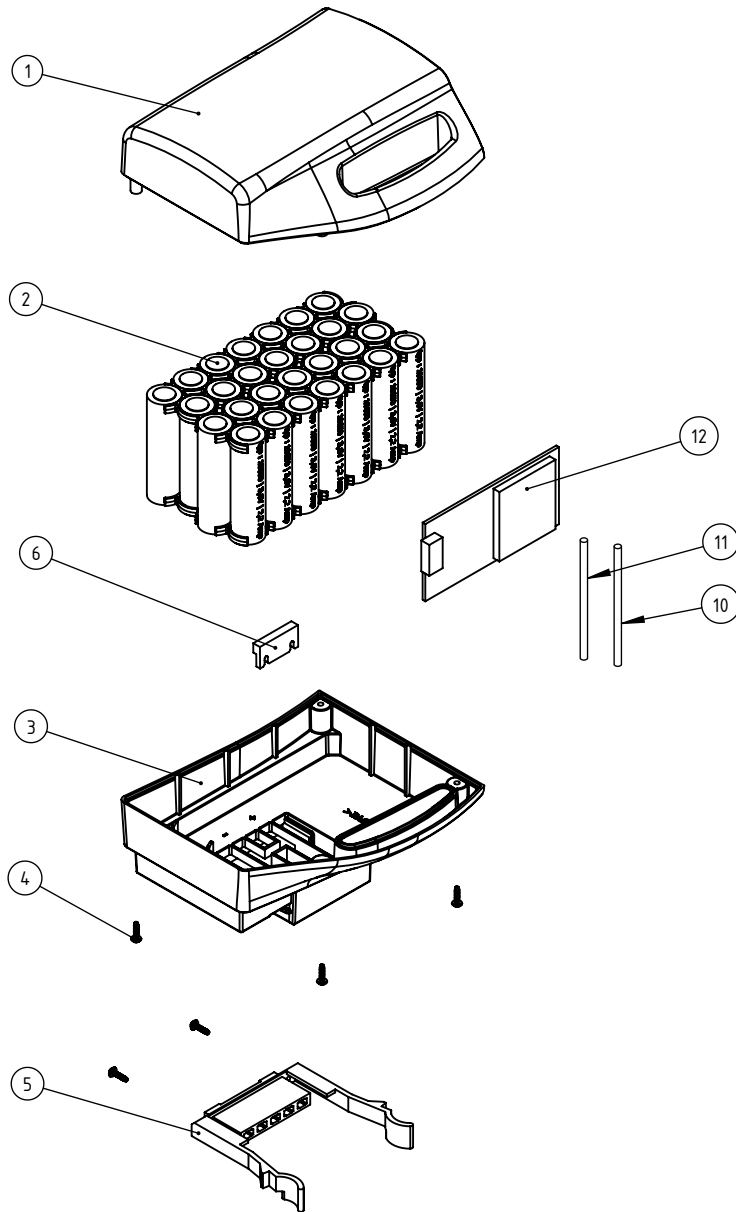

Item	P/N	Description	Qty.
	S.72.0079.2BSRA	ASSY BATTERY PACK GREY RIGHT BMS (FIRE RES) (W/O FUSE)	
1	72.0132.2R	BATTERY PACK HOUSING TOP RIGHT (FIRE RESISTANT)	1
2	72.0131.1/A	BATTERY PACK CELLS WITH BMS (8.8Ah) (W/O FUSE)	1
3	72.0079.2R	BATTERY PACK HOUSING BOTTOM RIGHT WHITE (FIRE RESISTANT)	1
4	72.0057.0	SCREW WN 5451 25X10 EJOT DELATA PT (MCH 1416-1001-2150)	6
5	72.0075.357	BATTERY CONNECTOR FEMALE, GREY, RIGHT (P431C)	1
6	72.0218.0	LIMITATION BLOCK FEMALE CONNECTOR	1
7	72.0170.0 NO SHOW	BUBBLE WRAP BAG 250x210	1
8	89.0469.2099.05 NO SHOW	SERIAL NO. BATTERY	1
9	89.0469.2099.07BM NO SHOW	STICKER SAFETY ADVISE FOR BATTERY RIGHT BMS	1
10	72.0129.0	BATTERY CONNECTOR + WIRES 14AWG, RED, L=250mm	1
11	72.1030.0	BATTERY CONNECTOR + WIRES 14AWG, BLACK, L=250mm	1
12	72.0284.0	BMS BOARD IMOP BATTERY	1

TOLERANCES UNSPECIFIED		REMARK:		SMT-FCT DONGGUAN THE FRIENDLY FAMILY 东莞硕能塑胶模具有限公司 ASSEMBLY AND MOULDING OF CLEANING			
LINE	ANGLE	-					
.xxx ±0.005	x ±2°	MATERIAL: -		APPROVED	CHECKED	DISGND	REV.
.xx ±0.05	.x ±1.5°					CONNIE	UNIT
.x ±0.1	.xx ±1°						mm
. ±0.2	.xxx ±0.5°						PART NAME
xx ±0.5							IMOPXXLN.FCT.7 EXPLODED VIEW
xxx ±1							PART NO
							IMOPXXLN.FCT.7
							SIZE
							A4

Revision		Description		Revised	Date	PAGE		20 / 21	
A		FIRST RELEASE		CONNIE	29/Aug/2019				

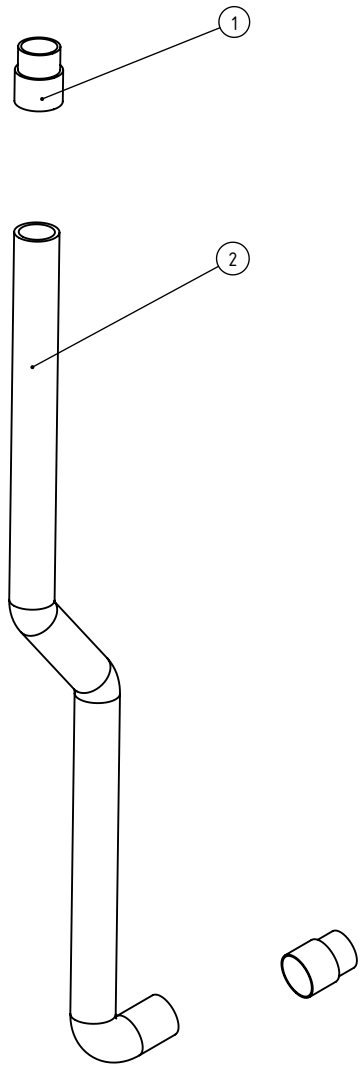

Item	P/N	Description	Qty.
	S.72.0094.0	STRETCH HOSE COMPLETE	
1	72.0095.8	STRETCH HOSE CUFF YELLOW	2
2	72.0094.0	STRETCH HOSE TOP UNIT [MCH 1416-1001-2098]	1

TOLERANCES UNSPECIFIED		REMARK: -		SMT-FCT DONGGUAN THE FRIENDLY FAMILY 东莞硕能塑胶模具有限公司 ASSEMBLY AND MOULDING OF CLEANING					
LINE	ANGLE	MATERIAL: -							
.xxx ±0.005	x ±2°	APPROVED	CHECKED	DISGNE	REV.	A	PART NAME	IMOPXXLN.FCT.7 EXPLODED VIEW	
.xx ±0.05	.x ±1.5°			CONNIE	UNIT	mm	PART NO	IMOPXXLN.FCT.7	SIZE
.x ±0.1	.xx ±1°				SCALE		PROJECT		A4
. ±0.2	.xxx ±0.5°								
xx ±0.5									
xxx ±1									
SHEET 1 OF 1	DATE			29/Aug/2019					

1	2		3		4		5		6	
Revision	Description		Revised	Date						
A	FIRST RELEASE		CONNIE	29/Aug/2019						
				PAGE		21 / 21				

A

B

C

D

A

B

C

D

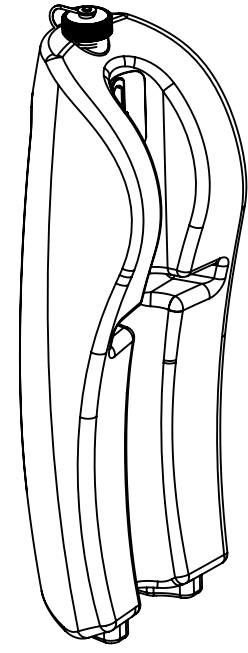
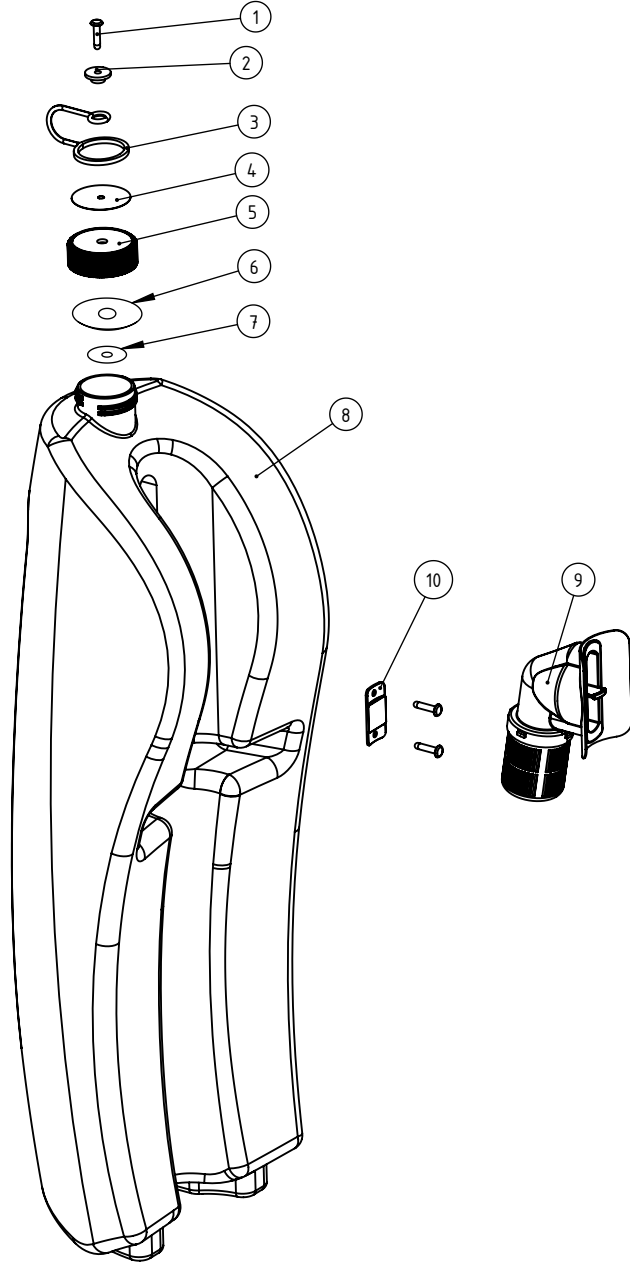

Item	P/N	Description	Qty.
	S.72.1088.0F	DIRT COMPARTMENT XXL FLOAT BALL	
1	54.0029.0	BLIND REVIT NAIL 4X15mmg	3
2	72.0254.0	SLEEVE CAP HOLDER	1
3	72.0252.0	CAP HOLDER	4
4	89.0469.2099.25A	WARNING PLATE ON DIRTY TANK ROUND STAINLESS PLATE 4.5mm	1
5	72.0264.357	CAP WITHOUT HOLE COLOR: GREY (P431C)	1
6	72.0265.0	SEALING GASKET CAP DIRTY TANK	1
7	72.0271.0	PLASTIC WASHER 9x4x1mm	1
8	72.1088.0	RECOVERY COMPARTMENT XXL	1
9	S.72.0407.8	ASSY FLOAT BALL	1
10	72.0347.0	FILTER CASSETTE RECOVERY TANK	1
11	72.1088.0-REWORK	REWROK FOR FLOATING SYSTEM	

TOLERANCES UNSPECIFIED		REMARK: -		SMT-FCT DONGGUAN THE FRIENDLY FAMILY 东莞硕能塑胶模具有限公司 ASSEMBLY AND MOULDING OF CLEANING							
LINE	ANGLE	-						MATERIAL: -			
.xxx	±0.005	x	±2°	APPROVED	CHECKED	DISGNE	REV.	A	PART NAME	IMOPXXLN.FCT.7 EXPLODED VIEW	
.xx	±0.05	.x	±1.5°			CONNIE	UNIT	mm	PART NO	IMOPXXLN.FCT.7	SIZE
.x	±0.1	.xx	±1°				SCALE	1:1	PROJECT		A4
.	±0.2	.xxx	±0.5°								
xx	±0.5										
xxx	±1										
SHEET OF	DATE	29/Aug/2019									