

Clemas
CLEANING MACHINES

i-mop XL Parts Manual



Unit 16 Alexandra Way, Ashchurch Business Centre,
Tewkesbury, GL20 8NB

Phone No. 01684 850 777 Email. info@clemas.co.uk

Website. www.clemas.co.uk

1		2		3		4		5		6	
Revision	Description			Revised	Date						
A	FIRST RELEASE			CONNIE	26/Sep/2017						
										PAGE	1 / 22

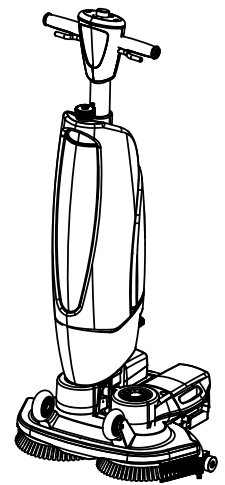
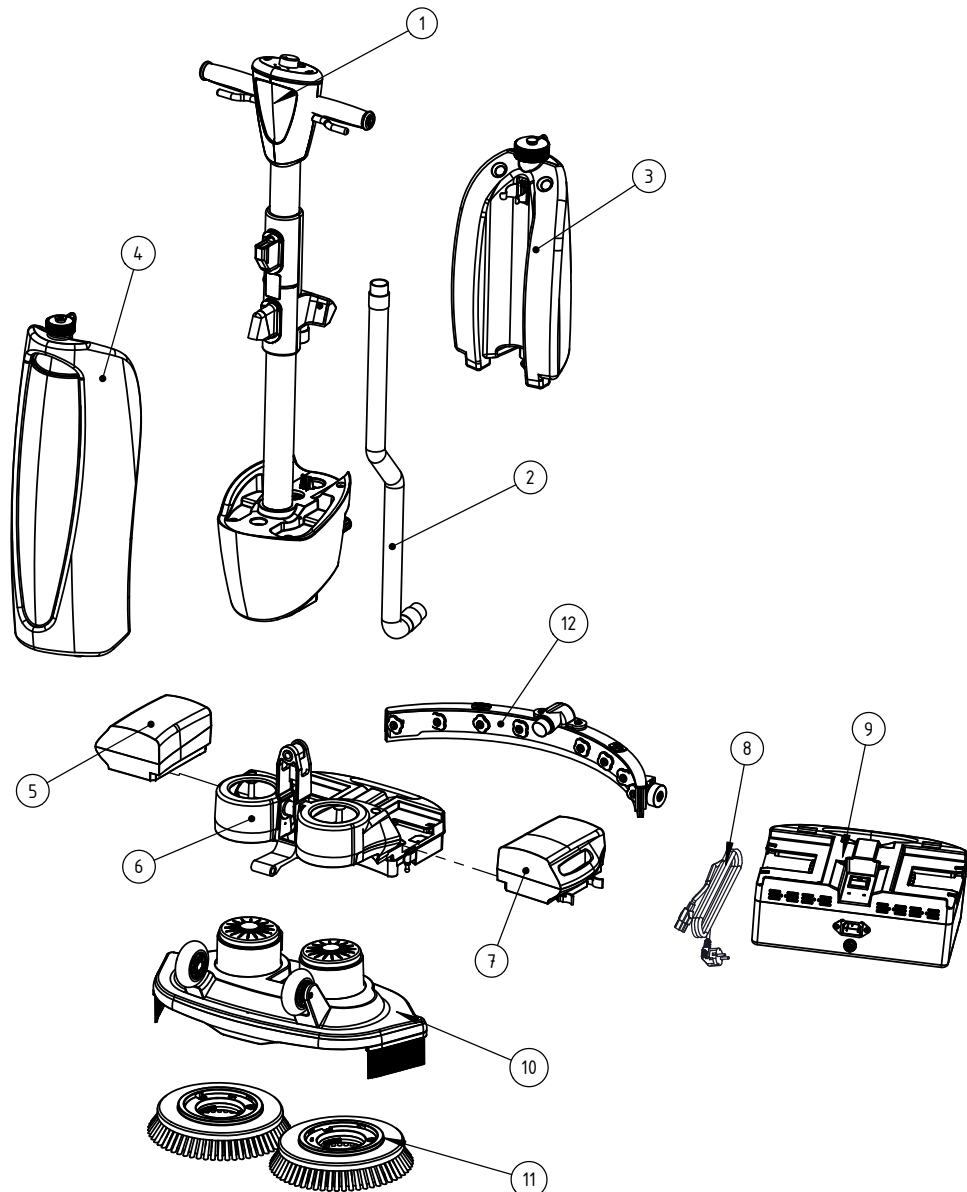

Item	P/N	Description	Qty.
1	TU.IMOP.230.2/797	ASSY TOP UNIT IMOP, BLUE BUTTON	1
2	S.72.0094.0	STRETCH HOSE COMPLETE	1
3	S.72.0081.1	ASSY CLEAN COMPARTMENT COMPLETE	1
4	S.72.0088.1	DIRT COMPARTMENT [NEW]	1
5	S.72.0079.2BSRA	ASSY BATTERY PACK GREY [RIGHT] BMS [FIRE RES] [W/O FUSE]	1
6	S.72.0065.2	ASSY MAIN LEVER UNIT IMOP [MCH 1416-1001-1004]	1
7	S.72.0074.2BSRA	ASSY BATTERY PACK BLUE [LEFT] BMS [FIRE RES] [W/O FUSE]	1
8	72.0152.9	POWER CORD 3P/1 AUS, 1.5 METER	1
9	S.72.0299.B/1	IMOP BATTERY MCU CHARGER 3 PIN	1
10	BU.IMOP.230.36	ASSY BRUSH UNIT IMOP 24V SILVER	1
11	S.72.0092.797/797	ASS BRUSH IMOP COMPLETE BLUE BRISTLE, BLUE LOCKER	2
12	S.72.0096.0	SQUEEGEE ASSEMBLY [MCH 1416-1001-1006]	1
13	72.0042.2099.00 NO SHOW	MANUAL IMOP [ENGLISH]	1
14	72.0042.2099.03 NO SHOW	MANUAL IMOP CHARGER [ENGLISH]	1
15	72.0142.11 NO SHOW	DAMP-PROOF BAG 30g	2

TOLERANCES UNSPECIFIED		REMARK:		<p style="text-align: center;">SMT-FACT DONGGUAN THE FRIENDLY FAMILY 东莞硕能塑胶模具有限公司 ASSEMBLY AND MOULDING OF CLEANING</p>			
LINE	ANGLE	-					
.xxx ±0.005	x ±2°	MATERIAL: -		APPROVED	CHECKED	DISGNE	REV.
.xx ±0.05	.x ±1.5°					CONNIE	A
.x ±0.1	.xx ±1°						UNIT
. ±0.2	.xxx ±0.5°						mm
xx ±0.5							SCALE
xxx ±1							PROJECT
SHEET 1 OF 1		DATE		26/Sep/2017		A4	

1	2		3		4		5		6	
Revision	Description		Revised	Date						
A	FIRST RELEASE		CONNIE	25/Sep/2017	PAGE 2 / 22					

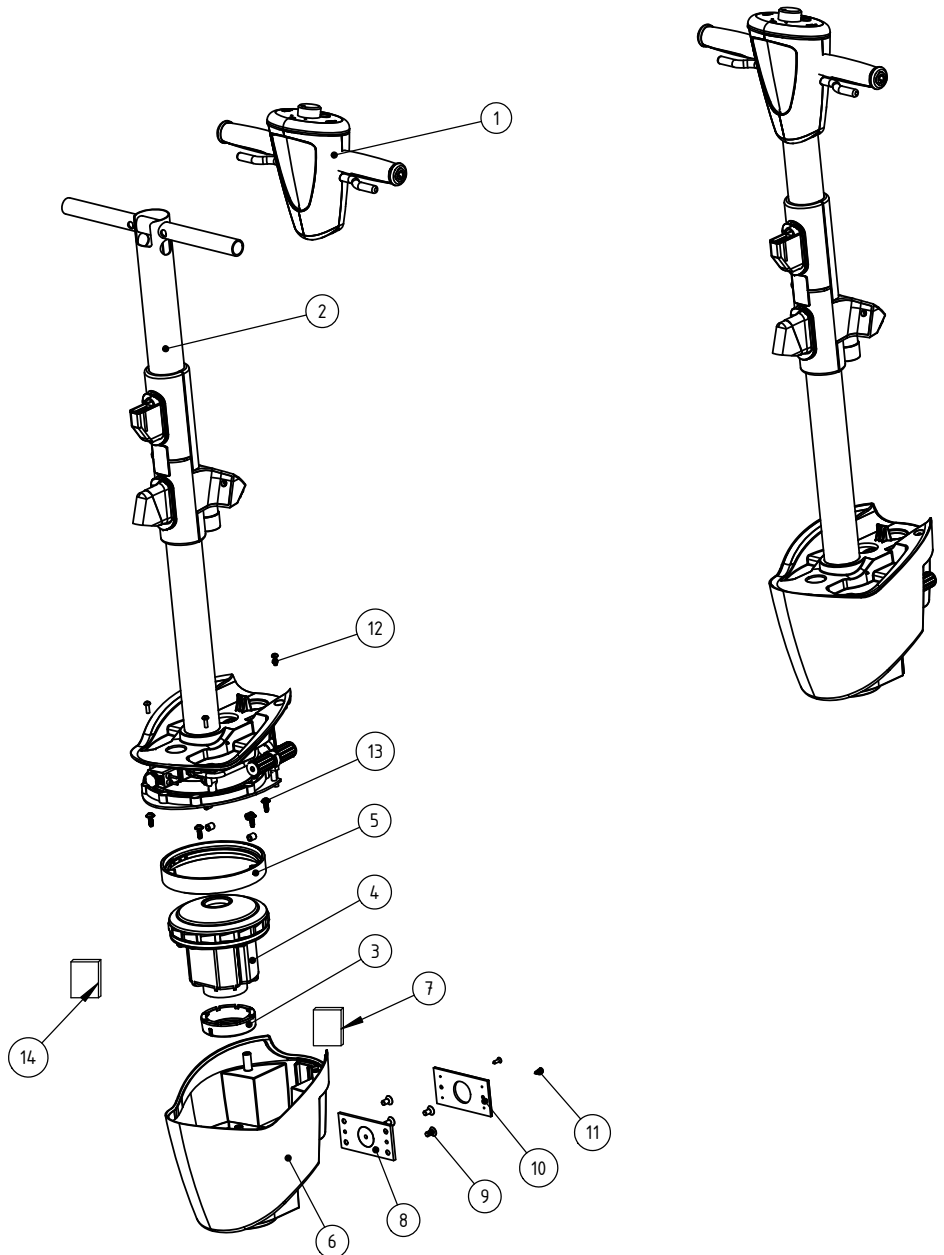

Item	P/N	Description	Qty.
	TU.IMOP.230.2/797	ASSY TOP UNIT IMOP, BLUE BUTTON	
1	S.72.0059.2/797	ASSY CONTROL UNIT, BLUE	1
2	S.72.0040.0	ASSY INLET TUBE [MCH 1416-1001-1024]	1
3	72.0034.0	VACUUM MOTOR SEALING BOTTOM [MCH 1416-1001-2047]	1
4	72.0035.0	DOMEL VACUUM CLEANER MOTOR [69.0007.0]	1
5	72.0112.0/A	VACUUM MOTOR SEALING SUPPORT [VER1]	1
6	72.0111.357	MOTOR UNIT COVER [MCH 1416-1001-2118], Kleur: Grey .357 P43	1
7	72.0051.0	MAGNET TOP UNIT 40X20X10MM [MCH 1416-1001-2044]	1
8	S.72.0031.2A	HINGE WELDING ASSY TOP UNIT [Ver2]	1
9	72.0033.1	COUNTER SUNK HEAD CAP SCREW M6X12 WITH NYLOK GLUE	4
10	72.0241.357	PLASTIC PLATE FOR HINGE WELDING ASSY, Kleur: Grey .357 (P43)	1
11	72.0240.0	COUNT SUNK SCREW M3.5X13 PHILPS HEAD	2
12	72.0121.1	SCREW M4X12, CROSS HEAD, STANDARD THREAD, SST	4
13	72.0026.0	SCREW WN 5451 50X14 EJOT DELTA PT	6
14	89.0467.2099.02	SERIAL NO. VACUUM MOTOR	1

TOLERANCES UNSPECIFIED		REMARK:		SMT-FCT DONGGUAN THE FRIENDLY FAMILY 东莞硕能塑胶模具有限公司 ASSEMBLY AND MOULDING OF CLEANING	
LINE	ANGLE	-			
.xxx ±0.005	x ±2°	MATERIAL: -		APPROVED	CHECKED
.xx ±0.05	.x ±1.5°	DISGNE	REV.	A	PART NAME
.x ±0.1	.xx ±1°	CONNIE	UNIT	mm	IMOPXL.ABC.1407C-1 EXPLODED VIEW
. ±0.2	.xxx ±0.5°	DATE	SCALE	PROJECT	SIZE
xx ±0.5		25/Sep/2017			A4
xxx ±1					

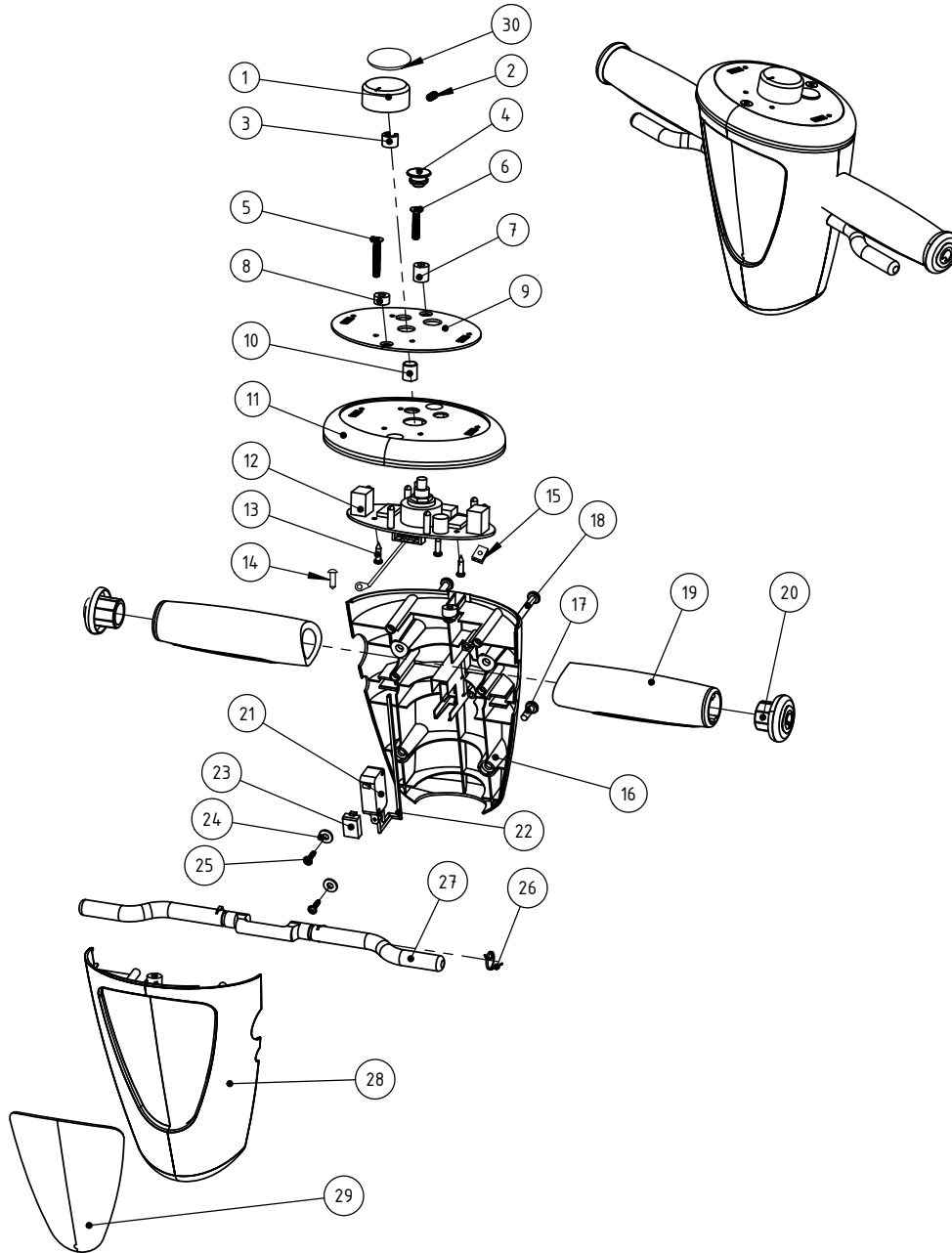

Item	P/N	Description	Qty.
	S.72.0059.2/797	ASSY CONTROL UNIT, BLUE	
1	72.0155.4/797	TURNING BUTTON NODIC OXIDATION M.AL, BLUE P312C	1
2	00.0115.0	HEXAGON SOCKET SET SCREW M4 X 8	1
3	72.0272.0	FIXATION INSERT TURNING BUTTON	1
4	72.0225.0/A	RUBBER BLOCK WATER SAVE ADJUSTMENT HOLE [A]	1
5	72.0273.0	M4X25 COUNTERSUNK SCREW STAINLESS STEEL	1
6	72.0273.1	M4X20 COUNTERSUNK SCREW STAINLESS STEEL	1
7	72.0276.0	SUPPORT PLASTIC BUSH TOP AL STICKER LONG	1
8	72.0276.1	SUPPORT PLASTIC BUSH TOP AL STICKER SHORT	1
9	89.0467.2099.00B	AL. STICKER IMOP [PLATE] [B]	1
10	72.0203.0	WATER SAVE BUTTON	1
11	72.0061.2/A	TOP HOUSING CONTROL UNIT Color: White [A]	1
12	72.0062.0/D	ASSY PCB LOCK CONNECTOR CONTROL UNIT [D] [BLUE]	1
13	85.1008.1	SCREW M3 X12 CROSSHEAD SELFTAPPING BL-NI, SST	1
14	00.0002.7	SCREW 4 X 10	3
15	72.0263.0	SWITCH WIRE CLAMP, Kleur: Black	1
16	72.0059.2/A	REAR HOUSING CONTROL UNIT Color: White [A]	1
17	72.0121.1	SCREW M4X12, CROSS HEAD, STANDARD THREAD, SST	2
18	72.0122.1	SCREW M4X35CROSS HEAD, STANDARD THREAD, SST	2
19	72.0230.357	HANDLE GRIP WITHOUT PROTRUSION, Kleur: Grey.357 (P431C)	2
20	72.0229.797	END CAP GRIP WITH LOGO, Kleur: Blue .797 (P312C)	2
21	72.0060.2	POWER SWITCH CONTROL UNIT OMORON	1
22	72.0120.0	ON/OFF SWITCH WIRES / L=250MM	1
23	72.0211.2	RUBBER BLOCK 15x10x5mm INJECTED	1
24	72.0271.0	PLASTIC WASHER 9x4x1mm	2
25	72.0057.0	SCREW WN 5451 25X10 EJOT DELTA PT [MCH 1416- 1001-2150]	2
26	72.0228.1	SPRING_SWITCH LEVER DIA.0.8MM (Ver.1)	1
27	72.0063.797	HANDLE CONTROL UNIT [MCH 1416-1001-2065], Kleur: Blue .797	1
28	72.0064.2/A	FRONT HOUSING CONTROL UNIT Color: White [A]	1
29	S.89.0467.2099.01E	ASSY AL.PLATE STICKER E WITH CLIP + 3M TAPES [HANDLE]	1
30	89.0469.2099.24	REMOVE STICKER ON THE SWITCH	1

TOLERANCES UNSPECIFIED		REMARK:		SMT-FCT DONGGUAN THE FRIENDLY FAMILY 东莞硕能塑胶模具有限公司 ASSEMBLY AND MOULDING OF CLEANING			
LINE	ANGLE	-		MATERIAL: -			
.xxx ±0.005	x ±2°	APPROVED	CHECKED	DISGNE	REV.	A	PART NAME
.xx ±0.05	.x ±1.5°			CONNIE	UNIT	mm	IMOPXL.ABC.1407C-1 EXPLODED VIEW
.x ±0.1	.xx ±1°						PART NO
. ±0.2	.xxx ±0.5°						IMOPXL.ABC.1407C-1
xx ±0.5							SCALE
xxx ±1							PROJECT
SHEET 1 OF 1		DATE		26/Sep/2017		A4	

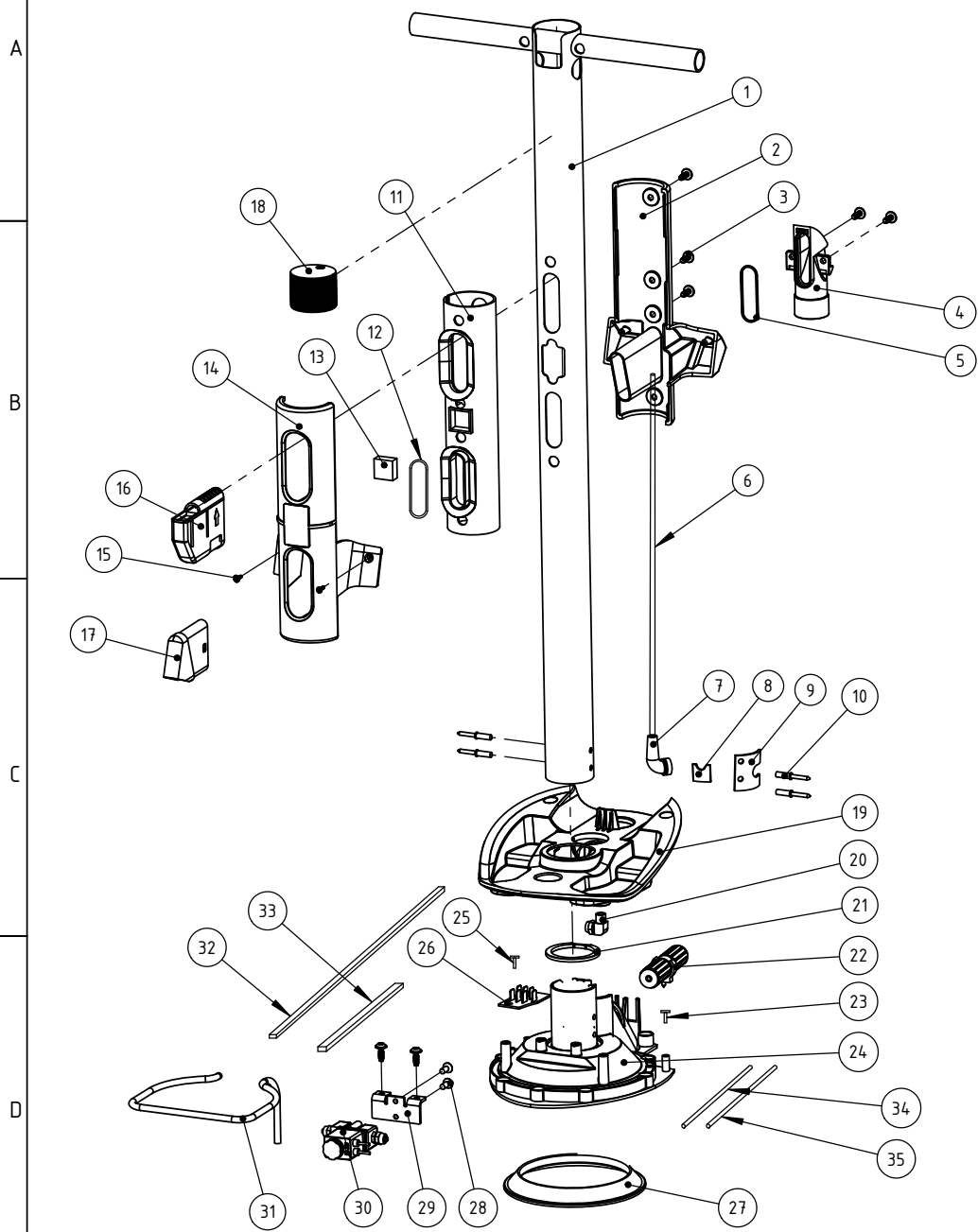

Item	P/N	Description	Qty.
	S.72.0040.0	ASSY INLET TUBE [MCH 1416-1001-1024]	
1	S.72.0041.0	ASSY INLET TUBE WELDING - 1 PIECE [MCH 1416-1001-1025]	1
2	72.0055.357	TANK HOLDER REAR [MCH 1416-1001-2197], Kleur: Grey .357	1
3	72.0026.0	SCREW WN 5451 50X14 EJOT DELTA PT	6
4	72.0056.357	STRETCH HOSE CONNECTOR [MCH 1416-1001-2199], Kleur: Grey .35	1
5	72.0296.0	GASKET FOR HOSE CONNECTOR	1
6	72.0039.0/D	UTP CABLE (MULTIPLE WIRES) RJ45 <- YH2.0-8P CONNECTOR L=100	1
7	72.0042.0	POWER CABLE GUIDING RUBBER [MCH 1416-1001-2187]	1
8	72.0268.0	SEALING RUBBER SHEET AL TUBE	1
9	72.0267.0	SEALING PRESSUR PLATE	1
10	72.0119.0	RIVET WITH DIA. 5MM & LENGTH 10 MM	4
11	72.0052.0	DIRT COMPARTMENT SEAL [MCH 1416-1001-2081]	1
12	72.0160.0	O RING WIRE DIA.3MM, OD46MM	1
13	72.0053.0	MAGNET TOP UNIT SMALL 20X20X10MM [MCH 1416-1001-2172]	1
14	72.0054.357	TANK HOLDER FRONT [MCH 1416-1001-2196], Kleur: Grey .357	1
15	72.0057.0	SCREW WN 5451 25X10 EJOT DELTA PT [MCH 1416-1001-2150]	2
16	S.72.0189.0	ASSY FILTER FOAM CASSETTE I-MOP	1
17	72.0163.1/996	TRANSPARENT PLASTIC DEFLECTOR DIRTY TANK	1
18	72.0038.0A	END CAP INLET TUBE [MCH 1416-1001-2152]	1
19	72.0113.357	MOTOR UNIT TOP [MCH 1416-1001-2123], Kleur: Grey .357	1
20	72.0049.1	ANGLE METAL CONNECTOR	1
21	72.0044.0	MOTOR UNIT FRAME RUBBER [MCH 1416-1001-2189]	1
22	S.72.0243.0	ASSEMBLY SIGAR UTP CONNECTOR	1
23	72.0240.0	COUNT SUNK SCREW M3.5X13 PHILPS HEAD	1
24	72.0114.357	MOTOR UNIT FRAME [MCH 1416-1001-2122], Kleur: Grey .357	1
25	85.1008.1	SCREW M3 X12 CROSSHEAD SELFTAPPING BL-NI, SST	1
26	72.0182.0/A	PCB MAGNETIC VALVE & VAC MOTOR CONNECTION [A]	1
27	72.0045.0/A	VACUUM MOTOR SEALING TOP SHARE HARDNESS 45	1
28	72.0206.1	SCREW WN 5451 50X14 EJOT DELTA PT	2
29	72.0050.0	MAGNETIC VENTIL FIXATION PLATE STAINLESS STEEL	1
30	72.0026.5	ASSY COPPER MANNETIC VALVE METAL CONNECTORS & COPPER PLATE	4
31	72.0022.2	WATER CHANNEL DIA.6MM L:225mm	1
32	72.0209.0	SEALING GASKET EVA 3X1.5X593MM	1
33	72.0210.0	SEALING GASKET EVA 4X2.5X150MM	1
34	72.0127.0	187 TERMINAL + WIRE 14AWG, RED, L=280mm, 250 TERMINAL	1
35	72.0128.0	187 TERMINAL + WIRE 14AWG, BLACK, L=280mm, 250 TERMINAL	1
36	00.0117.0 NO SHOW	GULE ND401	1
37	72.0232.0 NO SHOW	THREAD SEALING ADHESIVE	0.02

TOLERANCES UNSPECIFIED		REMARK: -					
LINE	ANGLE			东莞硕能塑胶模具有限公司 ASSEMBLY AND MOULDING OF CLEANING			
.xxx ±0.005	x ±2°			APPROVED CHECKED DISGNED REV. A PART NAME IMOPXL.ABC.1407C-1 EXPLODED VIEW			
.xx ±0.05	.x ±1.5°			MATERIAL: -			
.x ±0.1	.xx ±1°			CONNIE UNIT mm PART NO IMOPXL.ABC.1407C-1 SIZE			
. ±0.2	.xxx ±0.5°			SCALE PROJECT			
xx ±0.5				SHEET OF DATE 26/Sep/2017 A4			
xxx ±1				PROJECT			

1	2		3		4		5		6	
Revision	Description		Revised	Date						
A	FIRST RELEASE		CONNIE	26/Sep/2017	PAGE 5 / 22					

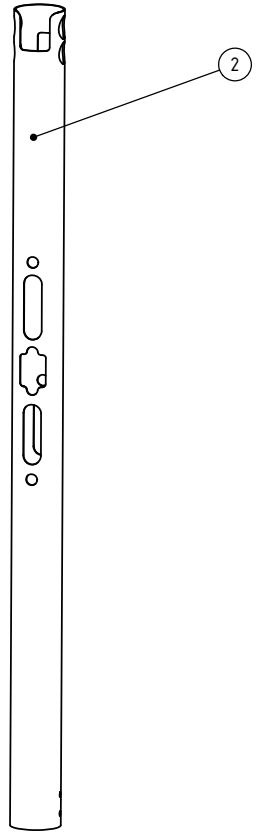
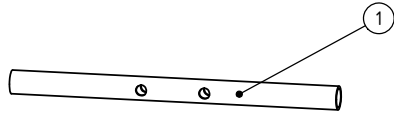

Item	P/N	Description	Qty.
	S.72.0041.0	ASSY INLET TUBE WELDING - 1 PIECE (MCH 1416-1001-1025)	
1	72.0040.0	INLET TUBE [MCH 1416-1001-2056]	1
2	72.0041.0	TUBE CONTROL UNIT-1 [MCH 1416-1001-2063]	1

TOLERANCES UNSPECIFIED		REMARK: -		SMT-FCT DONGGUAN THE FRIENDLY FAMILY 东莞硕能塑胶模具有限公司 ASSEMBLY AND MOULDING OF CLEANING					
LINE	ANGLE	MATERIAL: -							
.xxx ±0.005	x ±2°	APPROVED	CHECKED	DISGNE	REV.	A	PART NAME	IMOPXL.ABC.1407C-1 EXPLODED VIEW	
.xx ±0.05	.x ±1.5°			CONNIE	UNIT	mm	PART NO	IMOPXL.ABC.1407C-1	SIZE
.x ±0.1	.xx ±1°						PROJECT		A4
. ±0.2	.xxx ±0.5°								
xx ±0.5									
xxx ±1									
SHEET OF		DATE		26/Sep/2017		SCALE			

1		2		3		4		5		6	
Revision	Description			Revised	Date					PAGE	6 / 22
A	FIRST RELEASE			CONNIE	26/Sep/2017						

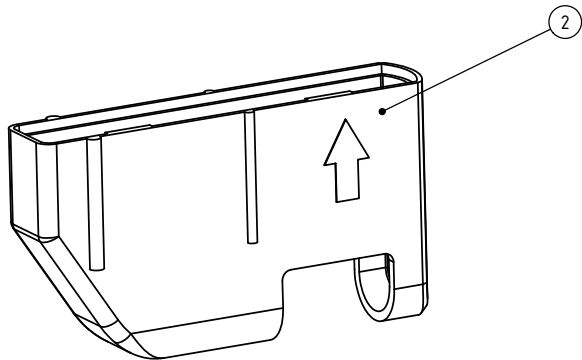
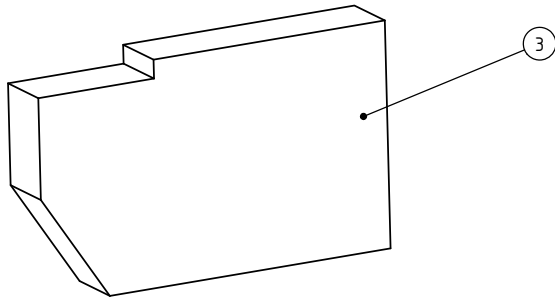
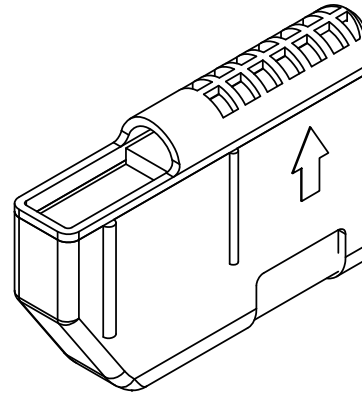
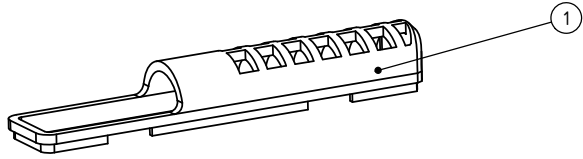

Item	P/N	Description	Qty.
	S.72.0189.0	ASSY FILTER FOAM CASSETTE I-MOP	
1	72.0189.0/8	COVER FILTER CASSETTE I-MOP, YELLOW	1
2	72.0189.1/8	FILTER CASSETTE I-MOP, YELLOW	1
3	72.0189.2	FILTER FOAM CASSETTE I-MOP	1
4	89.0469.2099.34A	GREEN ARROW + INSTRUCTION MARK	1

TOLERANCES UNSPECIFIED		REMARK: -		SMT-FCT DONGGUAN THE FRIENDLY FAMILY 东莞硕能塑胶模具有限公司 ASSEMBLY AND MOULDING OF CLEANING					
LINE	ANGLE	MATERIAL: -							
.xxx ±0.005	x ±2°	APPROVED	CHECKED	DISGNE	REV.	A	PART NAME	IMOPXL.ABC.1407C-1 EXPLODED VIEW	FIRST ANGLE PROJECTION
.xx ±0.05	.x ±1.5°			CONNIE	UNIT	mm	PART NO	IMOPXL.ABC.1407C-1	SIZE
.x ±0.1	.xx ±1°				SCALE		PROJECT		A4
. ±0.2	.xxx ±0.5°								
xx ±0.5									
xxx ±1									
SHEET OF	DATE			26/Sep/2017					

1	2		3		4		5		6	
Revision	Description		Revised	Date						
A	FIRST RELEASE		CONNIE	26/Sep/2017						
						PAGE		7 / 22		

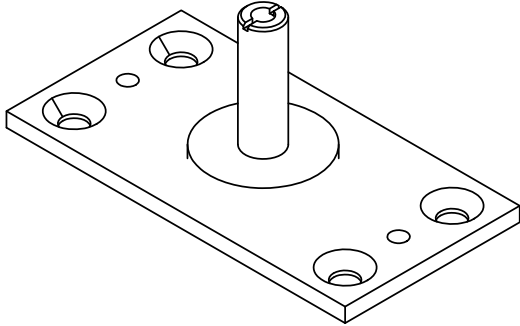
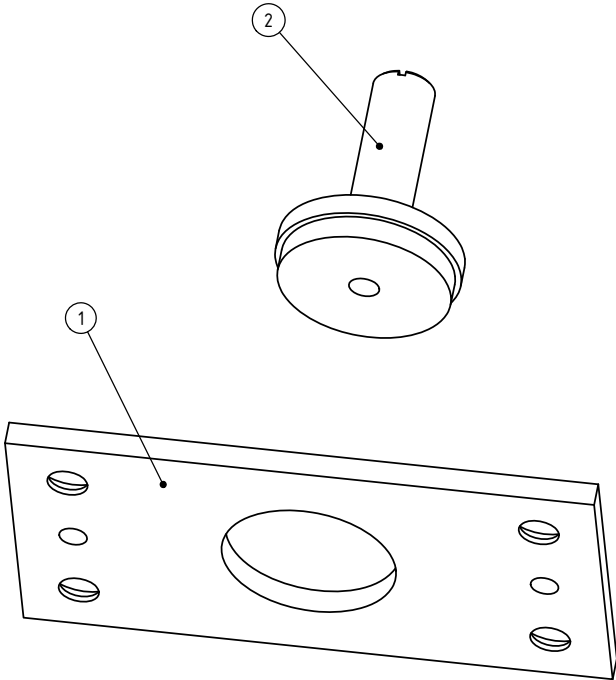

Item	P/N	Description	Qty.
	S.72.0031.2A	HING WEKDUBG ASSY TOP UNIT (VER2)	
1	72.0031.1	HINGE CONSTRUCTION PLATE TOP UNIT [Ver1]	1
2	72.0032.0	HINGE AXIS TOP UNIT [MCH 1416-1001-2027]	1

TOLERANCES UNSPECIFIED		REMARK: -		SMT-FACT DONGGUAN THE FRIENDLY FAMILY 东莞硕能塑胶模具有限公司 ASSEMBLY AND MOULDING OF CLEANING					
LINE	ANGLE	MATERIAL: -							
.xxx ±0.005	x ±2°	APPROVED	CHECKED	DISGNED	REV.	A	PART NAME	IMOPXL.ABC.1407C-1 EXPLODED VIEW	
.xx ±0.05	.x ±1.5°			CONNIE	UNIT	mm	PART NO	IMOPXL.ABC.1407C-1	SIZE
.x ±0.1	.xx ±1°				SCALE		PROJECT		A4
. ±0.2	.xxx ±0.5°	SHEET 1 OF 1		DATE		26/Sep/2017			
xx ±0.5									
xxx ±1									

1	2		3		4		5		6	
Revision	Description		Revised	Date						
A	FIRST RELEASE		CONNIE	26/Sep/2017	PAGE 8 / 22					

A

B

C

D

A

B

C

D

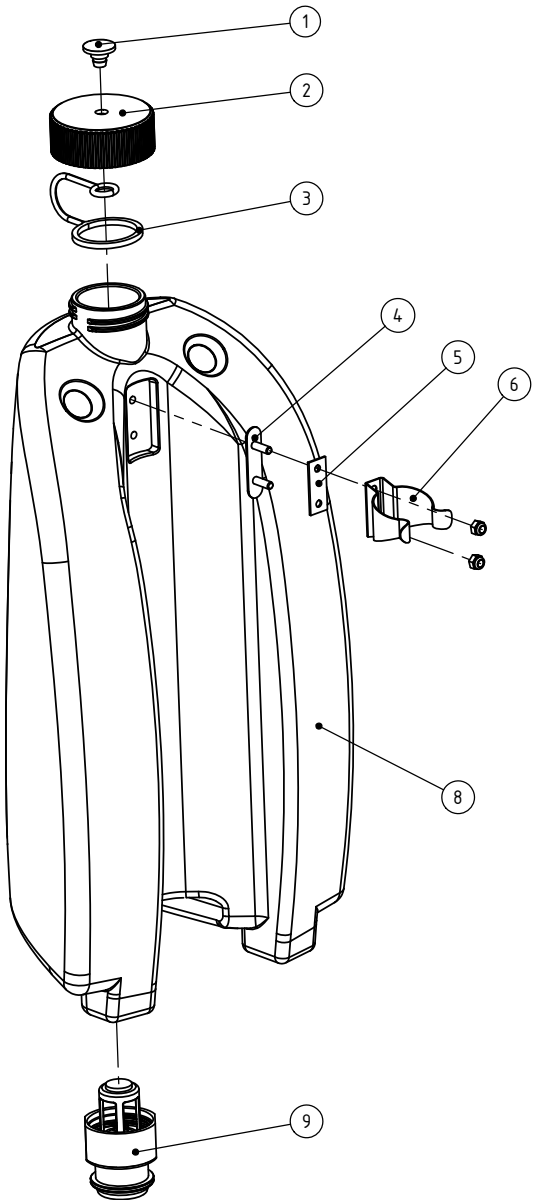

Item	P/N	Description	Qty.
	S.72.0081.1	ASSY CLEAN COMPARTMENT COMPLETE1	
1	72.0254.1	SLEEVE CAP HOLDER CLEAN TANK	1
2	72.0251.797	CAP WITH HOLE, BLEUR: BLUE .797 (P312C)	1
3	72.0252.0	CAP HOLDER	1
4	72.0253.0	HOLDER PLATE CLIP CLEAN TANK	1
5	72.0290.0	RUBBER CUSHION FOR METAL CLIP	1
6	72.0288.0	METAL CLIP CLEAN TANK	1
7	72.0261.0	NUT M4 NYLON STAINLESS	2
8	72.0081.1	CLEAN COMPARTMENT, CAP VERSION	1
9	S.72.0085.0	WATER COUPLING VERSION 2	1

TOLERANCES UNSPECIFIED		REMARK:			
LINE	ANGLE	-			
.xxx	±0.005	x	±2°	MATERIAL: -	
.xx	±0.05	.x	±1.5°		
.x	±0.1	.xx	±1°	APPROVED	CHECKED
.	±0.2	.xxx	±0.5°	DISGNE	REV.
xx	±0.5			CONNIE	UNIT
xxx	±1			mm	A
SHEET OF		DATE		26/Sep/2017	SCALE
				26/Sep/2017	SCALE
				UNIT	mm
				CONNECTION	SIZE
				PROJECT	A4

1		2		3		4		5		6	
Revision	Description			Revised	Date						
A	FIRST RELEASE			CONNIE	26/Sep/2017						
					PAGE		9 / 22				

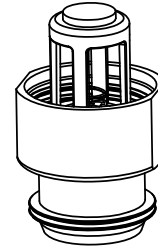
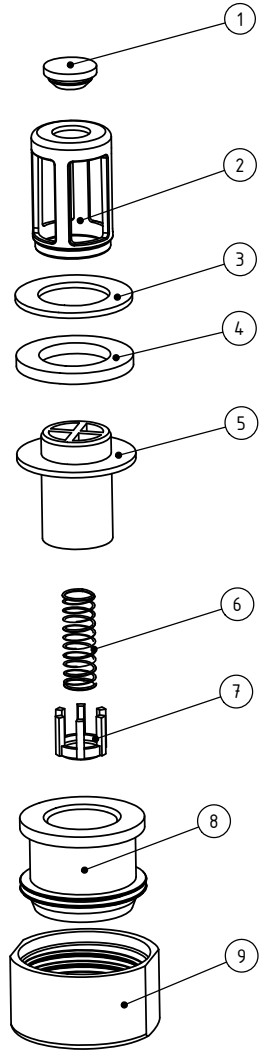

Item	P/N	Description	Qty.
	S.72.0085.0	WATER COUPLING VERSION 2	
1	72.0192.6	RUBBER BLOCK FILTER	1
2	72.0085.0	WATER COUPLING FILTER	1
3	72.0192.5	RUBBER GASKET ID 19mm, OD31mm, T=1.5mm	1
4	72.0192.5/A	RUBBER GASKET ID 19mm, OD31mm, T=3mm	1
5	72.0192.2/375A	HOUSING OF VALVE	1
6	72.0192.3/A	SPRINGWATER COUPLING (A)	1
7	72.0192.4/357A	VALVE WATER COUPLING, GREY (A)	1
8	72.0192.1	HOUSING WATER COUPLING	1
9	72.0289.0/8	METAL CAP WATER COUPLING, YELLOW	1

TOLERANCES UNSPECIFIED		REMARK: -		SMT-FCT DONGGUAN THE FRIENDLY FAMILY 东莞硕能塑胶模具有限公司 ASSEMBLY AND MOULDING OF CLEANING					
LINE	ANGLE	MATERIAL: -							
.xxx ±0.005	x ±2°	APPROVED	CHECKED	DISGNE	REV.	A	PART NAME	IMOPXL.ABC.1407C-1 EXPLODED VIEW	
.xx ±0.05	.x ±1.5°			CONNIE	UNIT	mm	PART NO	IMOPXL.ABC.1407C-1	SIZE
.x ±0.1	.xx ±1°				SCALE		PROJECT		A4
. ±0.2	.xxx ±0.5°								
xx ±0.5									
xxx ±1									
SHEET OF	DATE			26/Sep/2017					

1	2	3	4	5	6
Revision	Description	Revised	Date	PAGE 10 / 22	
A	FIRST RELEASE	CONNIE	26/Sep/2017		

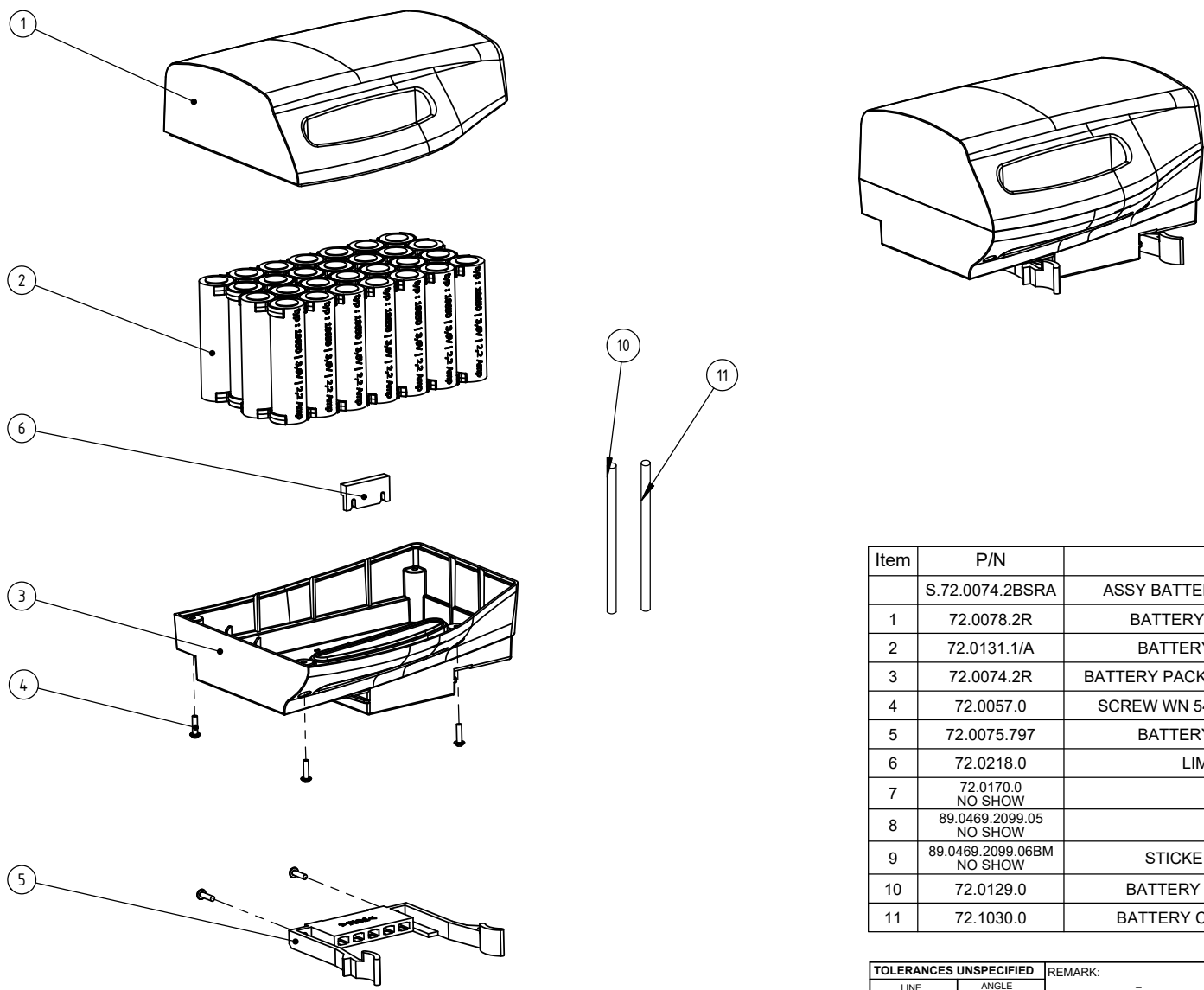

Item	P/N	Description	Qty.
	S.72.0074.2BSRA	ASSY BATTERY PACK BLUE LEFT BMS (FIRE RES) (W/O FUSE)	
1	72.0078.2R	BATTERY PACK HOUSING TOP LEFT (FIRE RESISTANT)	1
2	72.0131.1/A	BATTERY PACK CELLS WITH BMS (8.8Ah) (W/O FUSE)	1
3	72.0074.2R	BATTERY PACK HOUSING BOTTOM LEFT WHITE (FIRE RESISTANT)	1
4	72.0057.0	SCREW WN 5451 25X10 EJOT DELATA PT (MCH 1416-1001-2150)	6
5	72.0075.797	BATTERY CONNECTOR FEMALE, BLUE, LEFT (P312C)	1
6	72.0218.0	LIMITATION BLOCK FEMALE CONNECTOR	1
7	72.0170.0 NO SHOW	BUBBLE WRAP BAG 250x210	1
8	89.0469.2099.05 NO SHOW	SERIAL NO. BATTERY (C)	1
9	89.0469.2099.06BM NO SHOW	STICKER SAFETY ADVISE FOR BATTERY LEFT BMS	1
10	72.0129.0	BATTERY CONNECTOR + WIRES 14AWG, RED, L=250mm	1
11	72.1030.0	BATTERY CONNECTOR + WIRES 14AWG, BLACK, L=250mm	1

TOLERANCES UNSPECIFIED		REMARK:		SMT-FCT DONGGUAN THE FRIENDLY FAMILY 东莞硕能塑胶模具有限公司 ASSEMBLY AND MOULDING OF CLEANING			
LINE	ANGLE	-					
.xxx ±0.005	x ±2°	MATERIAL: -		APPROVED	CHECKED	DISGNE	REV.
.xx ±0.05	.x ±1.5°					CONNIE	A
.x ±0.1	.xx ±1°						PART NAME
. ±0.2	.xxx ±0.5°						IMOPXL.ABC.1407C-1 EXPLODED VIEW
xx ±0.5							PART NO
xxx ±1							IMOPXL.ABC.1407C-1
SHEET OF		DATE				26/Sep/2017	SCALE
							1:1
							PROJECT
							A4

1	2		3		4		5		6	
Revision	Description		Revised	Date					PAGE	11 / 22
A	FIRST RELEASE		CONNIE	26/Sep/2017						

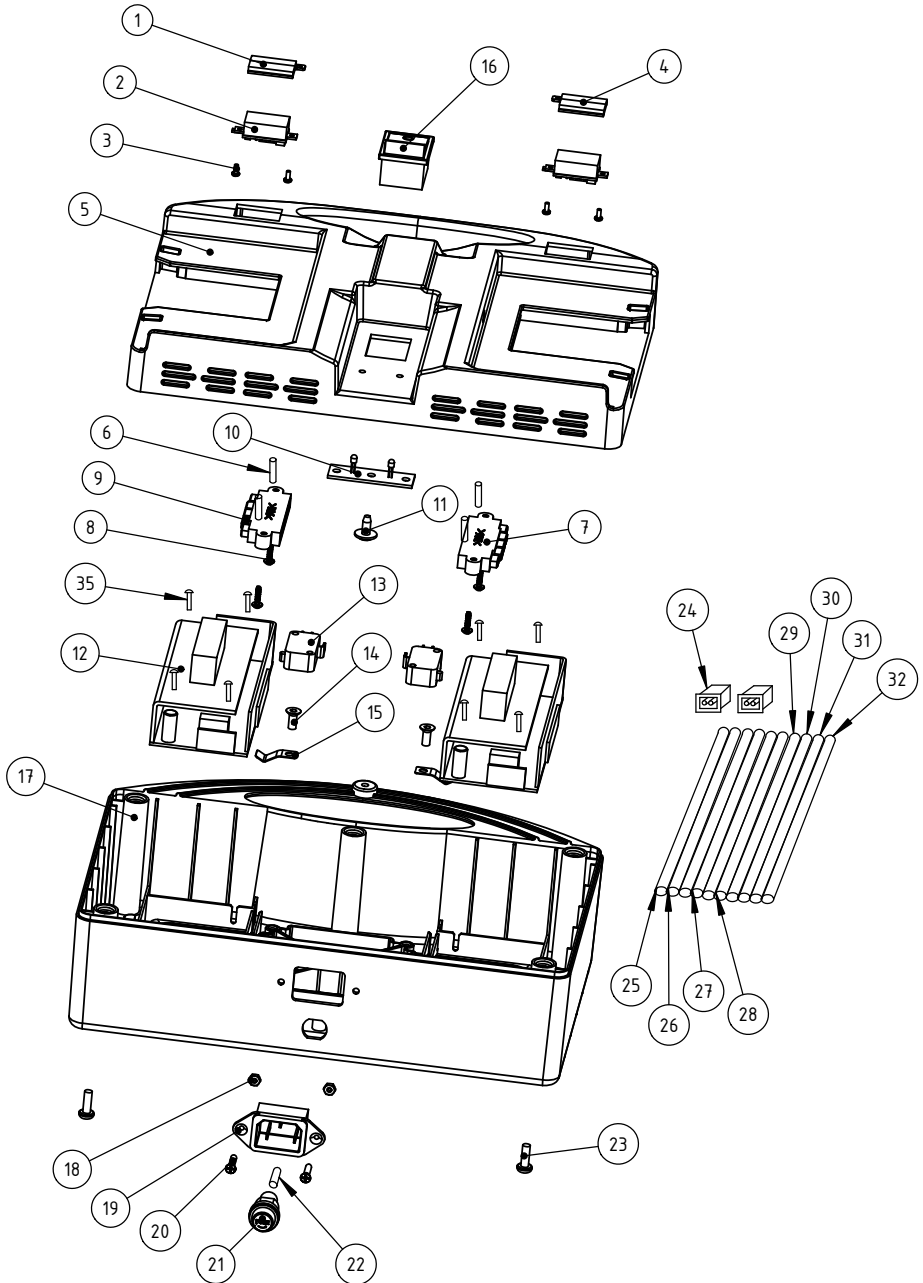

Item	P/N	Description	Qty.
	S.72.0299.B/1	IMOP BATTERY MCU CHARGER 3 PIN	
1	72.0275.1	TRANSPARENT COVER VOLTAGE DISPLAY RIGHT	1
2	72.0174.0/A	VOLTAGE DISPLAY WITH PERCENTAGE	2
3	72.0328.0	SCREW M2X 5 CROSS HEAD SELF TAPPING	4
4	72.0275.0	TRANSPARENT COVER VOLTAGE DISPLAY LEFT	1
5	72.0187.2R	NEW CHARGER TOP HOUSING WHITE [FIRE RESISTANT]	1
6	85.0050.1	ALIGNMENT PIN LONGER VERSION	4
7	72.0068.357	BATTERY CONNECTOR MALE, LEFT: GREY	1
8	72.0057.0	SCREW WN 5451 25X10 EJOT DELTA PT [MCH 1416-1001-2150]	4
9	72.0068.797	BATTERY CONNECTOR MALE, Right: BLUE	1
10	72.0197.0	LED PCB NEW CHARGER IMOP	1
11	85.1035.0	SCREW M3 X 10 CROSS HEAD WASHER SELF TAPPING BL-NI	1
12	72.0106.0/A	CHARGE UNIT MCU	2
13	72.0060.2	POWER SWITCH CONTROL UNIT OMORON	1
14	00.0002.7	SCREW 4 X 10	3
15	72.0205.0	WIRE CLAMP	2
16	04.0009.30	SWITCH 4P LIGHT GREEN 0/I	1
17	72.0188.357R	NEW CHARGER TOP BOTTOM HOUSING GREY [FIRE RESISTANT]	1
18	20.0031.5	NUT M3 NYLON	2
19	72.0002.3	RECEPT INLET 3P+TWO SCREW HOLES CB 3PIN	1
20	66.0301.0	COUNTER SUNK SCREW M3*15	2
21	72.0195.0	FUSE BASE 6.3A	1
22	72.0195.1	FUSE 6.3A	1
23	00.0121.0	SCREW ST4 X 9.3 CROSSHEAD SELFTAPED BL-NI	6
24	72.0124.1	HOUSING VH-2P	2
25	72.0193.4	WIRE RED INLET TO SWITCH	1
26	72.0123.0/A	MALE CONNECTOR + WIRES 18AWG BLACK 270MM	2
27	72.0124./0A	MALE CONNECTOR + CONNECTOR WIRES 18AWG BLACK 270MM	2
28	72.0144.0	2 CORD WIRE WITH CONNECTOR PCB	2
29	72.0193.0/A	WIRE BLACK/RED WITH TUBE CHARGER SWITCH	1
30	72.0193.2	WIRE BLACK INLET TO FUSE	1
31	72.0193.3	WIRE BLACK FUSE TO SWITCH	1
32	72.0193.5	GROUND WIRE YELLOW & GREEN	1
33	89.0469.2089.00 NO SHOW	SERIAL NO. BATTERY MCU CHARGER	1
34	72.0326.0 NO SHOW	CABLE TIE 3*130MM	1
35	72.0325.0	COUNTER SINK SELF TAP SCREW M3.6X15	8
36	89.0469.2089.01 NO SHOW	LABEL FOR FUSE SPEC	1

TOLERANCES UNSPECIFIED

LINE	ANGLE		
.xxx	±0.005	x	±2°
.xx	±0.05	.x	±1.5°
.x	±0.1	.xx	±1°
.	±0.2	.xxx	±0.5°
xx	±0.5		
xxx	±1		

REMARK: -

MATERIAL: -

APPROVED	CHECKED	DISGNE	REV.	A
		CONNIE	UNIT	mm
			SCALE	

SMT-FCT DONGGUAN
 THE FRIENDLY FAMILY
东莞硕能塑胶模具有限公司
 ASSEMBLY AND MOULDING OF CLEANING

PART NAME	IMOPXL.ABC.1407C-1 EXPLODED VIEW	PROJ AND REV	1-1
PART NO	IMOPXL.ABC.1407C-1	SIZE	A4

SHEET 1 OF 1

DATE: 26/Sep/2017

SCALE: PROJECT: A4

1		2		3		4		5		6	
Revision	Description			Revised	Date						
A	FIRST RELEASE			CONNIE	26/Sep/2017	PAGE 12 / 22					

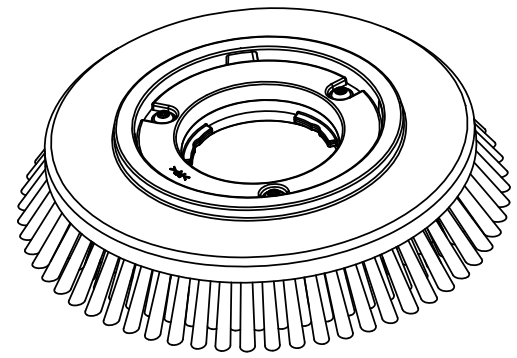
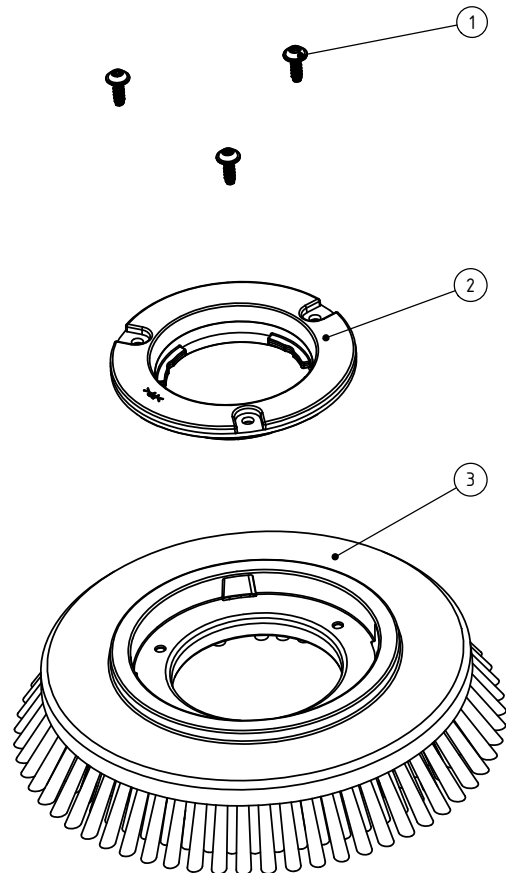

Item	P/N	Description	Qty.
	S.72.0092.797/797	ASS BRUSH IMOP COMPLETE BLUE BRISTLE, BLUE LOCKER	
1	72.0026.0	SCREW WN 5451 50X14 EJOT DELTA PT (MCH 1416-1001-2004)	3
2	72.0093.797	BRUSH LOCKER BLUE (P312C)	1
3	S.72.0091.797	ASSY BRUSH DISC BLUE (P312C)	1

TOLERANCES UNSPECIFIED		REMARK: -		SMT-FACT DONGGUAN THE FRIENDLY FAMILY 东莞硕能塑胶模具有限公司 ASSEMBLY AND MOULDING OF CLEANING					
LINE	ANGLE	MATERIAL: -							
.xxx ±0.005	x ±2°	APPROVED	CHECKED	DISGNE	REV.	A	PART NAME	IMOPXL.ABC.1407C-1 EXPLODED VIEW	
.xx ±0.05	.x ±1.5°			CONNIE	UNIT	mm	PART NO	IMOPXL.ABC.1407C-1	
.x ±0.1	.xx ±1°				SCALE		PROJECT		SIZE
. ±0.2	.xxx ±0.5°								A4
xx ±0.5		SHEET OF		DATE					
xxx ±1					26/Sep/2017				

1	2	3	4	5	6
Revision	Description	Revised	Date	PAGE 13 / 22	
A	FIRST RELEASE	CONNIE	26/Sep/2017		

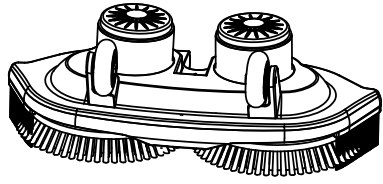
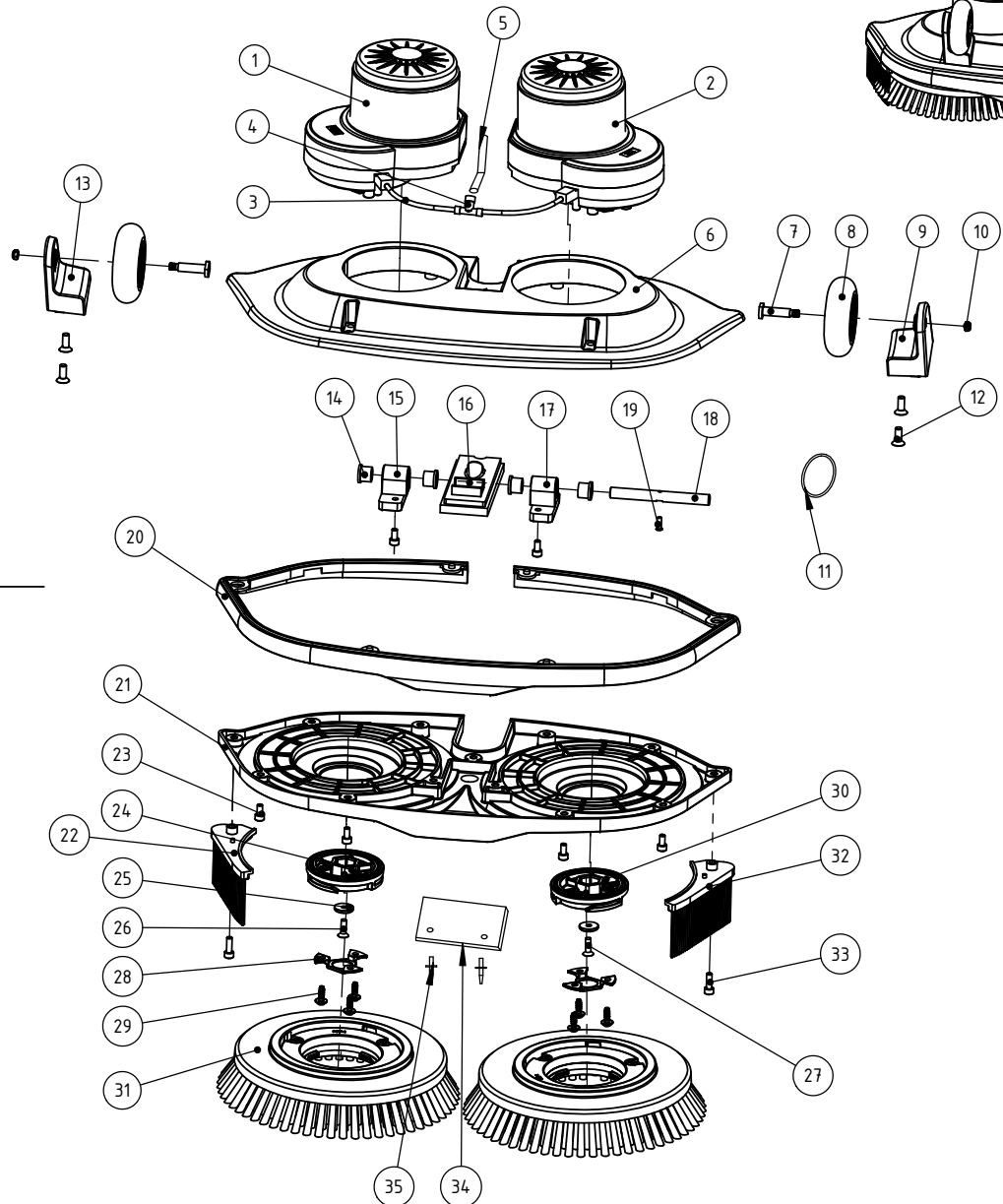

Item	P/N	Description	Qty.
	BU.IMOP.230.36	ASSY BRUSH UNIT IMOP 24V SILVER	
1	S.72.0000.1R	ASSY BRUSH MOTOR RIGHT	1
2	S.72.0000.0R	ASSY BRUSH MOTOR LEFT	1
3	72.0022.1	WATER CHANNEL DIA.4MM L:110mm [MCH 1416-1001-2109]	2
4	72.0109.0	WATER COUPLING BRUSH MOTOR	1
5	72.0022.0	WATER CHANNEL DIA.6MM L:570mm [MCH 1416-1001-2034]	1
6	72.0008.0	BRUSH MOTOR CONSTRUCTION COVER [MCH 1416-1001-2025]	1
7	72.0027.3	SHAFT TRANSPORT CASTOR [V2]	2
8	72.0029.2/797	WHITE CASTOR + BLUE BRACKET	2
9	72.0009.0/A	TRANSPORT WHEEL PILLAR LEFT LONG [NEW]	1
10	04.0048.0	NUT M5 NYLON	2
11	89.0469.2099.24	REMOVE STICKER ON THE SWITCH	2
12	72.0002.0N	NYLOK SCREW COUNTER SUNK BOLT M6X16 [MCH 1416-1001-2104]	4
13	72.0009.1/A	TRANSPORT WHEEL PILLAR RIGHT LONG [NEW]	1
14	72.0016.0	BRUSHING AXIS 10 [MCH 1416-1001-2112]	4
15	72.0015.1	BRUSH UNIT HINGE SUPPORT RIGHT [MCH 1416-1001-2186]	1
16	72.0021.0	CONSTRUCTION COVER SEAL [MCH 1416-1001-2115]	1
17	72.0015.0	BRUSH UNIT HINGE SUPPORT LEFT [MCH 1416-1001-2185]	1
18	72.0013.0	CHASSIS HINGE [MCH 1416-1001-2012]	1
19	72.0014.0N	NYLOK SCREW COUNTER SUNK BOLT M4x12	1
20	72.0023.0	BRUSH UNIT PROTECTOR [MCH 1416-1001-2102]	1
21	72.0110.357	BRUSH UNIT BOTTOM PART [MCH 1416-1001-2008], Kleur: Grey .35	1
22	72.0248.1	SPLASHING GUARD IMOP RIGHT	1
23	72.0017.0N	NYLOK SOCKET HEAD CAP SCREW M5X10	19
24	72.0024.1/357	DRIVING WHEEL BOTTOM RIGHT Color: Grey [P431C]	1
25	72.0025.1	SUPPORT DISC DRIVING WHEEL SIDE ,HOLE DIA.5MM	2
26	72.0014.3N/1	NYLOK SCREW COUNTER SUNK BOLT M5X18.5	1
27	72.0014.4N/1	NYLOK SCREW COUNTER SUNK BOLT M5X18.5[REVERSE THREAD BLACK]	1
28	72.0312.797	COVER BRUSH MOTOR SCREW, Kleur: Blue .797 (P312C)	2
29	72.0026.0	SCREW WN 5451 50X14 EJOT DELTA PT	6
30	72.0024.0/357	DRIVING WHEEL BOTTOM LEFT Color: Grey [P431C]	1
31	S.72.0092.797/797	ASS BRUSH IMOP COMPLETE BLUE BRISTLE, BLUE LOCKER	2
32	72.0248.0	SPLASHING GUARD IMOP LEFT	1
33	72.0260.0	NYLOK HEXAGON SOCKET HEAD CAP SCREWS M5X20 SST	2
34	89.0467.2099.04B	METAL PLATE IMOP THICKNESS:0.5MM	1
35	02.0005.10	BLIND RIVET 3 x 6	2
36	57.0076.0 NO SHOW	BLACK CABLE TIE 3 X 15 BLACK	1

TOLERANCES UNSPECIFIED		REMARK:		SMT-FCT DONGGUAN THE FRIENDLY FAMILY 东莞硕能塑胶模具有限公司 ASSEMBLY AND MOULDING OF CLEANING	
LINE	ANGLE	-			
.xxx ±0.005	x ±2°	MATERIAL: -		APPROVED	CHECKED
.xx ±0.05	.x ±1.5°	CONNIE	UNIT	DISGNE	REV.
.x ±0.1	.xx ±1°	mm	A	REV.	A
. ±0.2	.xxx ±0.5°	26/Sep/2017	SCALE	PART NAME	IMOPXL.ABC.1407C-1 EXPLODED VIEW
xx ±0.5		DATE	PROJECT	PART NO	IMOPXL.ABC.1407C-1
xxx ±1		SHEET 1 OF 1	SCALE	SIZE	A4

1	2		3		4		5		6	
Revision	Description		Revised	Date					PAGE	14 / 22
A	FIRST RELEASE		CONNIE	26/Sep/2017						

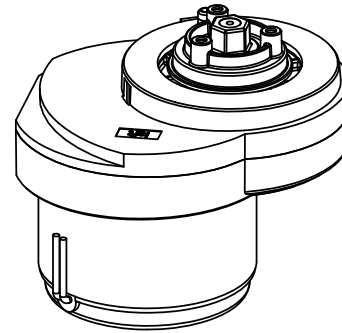
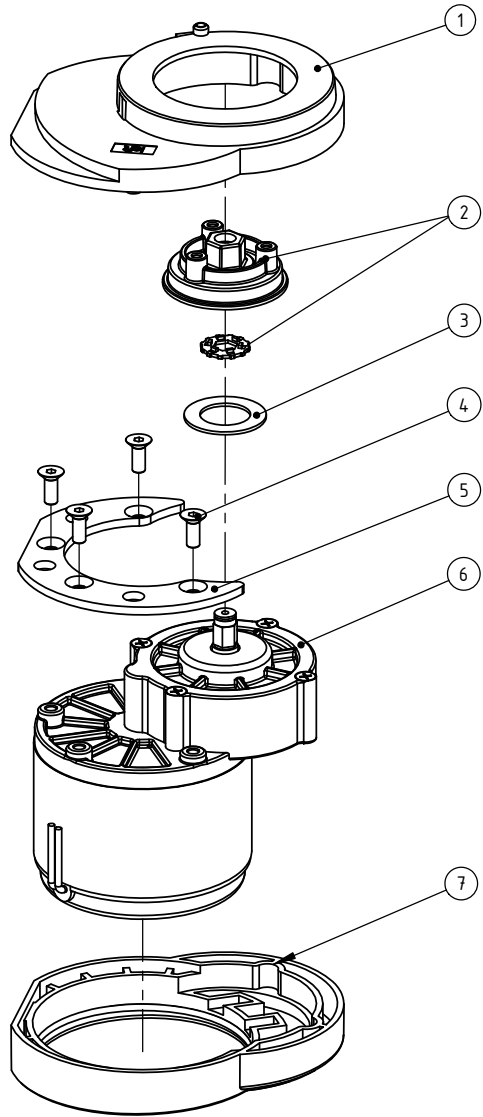

Item	P/N	Description	Qty.
	S.72.0000.0R	ASSY BRUSH MOTOR LEFT	
1	72.0007.0	BRUSH MOTOR SUPPORT SUPPORT RUBBER LEFT (MCH 1416-1001-2107)	1
2	72.0005.357/C	DRIVING WHEEL TOP WITH METAL INSERT (VER.1)	1
3	72.0004.0	FELT BRUSH MOTOR (MCH 1416-1001-2183)	1
4	72.0002.0N	NYLOK SCREW COUNTER SUNK BOLT M6X16 (MCH 1416-1001-2104)	4
5	72.0001.0	BRUSH MOTOR CONSTRUCTION RING LEFT (MCH 1416-1001-2106)	1
6	72.0000.0R	BRUSH MOTOR HELICAL GEARS LEFT	1
7	72.0006.0/A	BRUSH MOTOR FIXATION CONDUCTIVE RUBBER LEFT	1
8	72.0108.0 NO SHOW	LOCKTITE 222	0.02
9	89.0469.2099.00 NO SHOW	SERTAL NO. BRUSH MOTOR LEFT	1

TOLERANCES UNSPECIFIED		REMARK:		SMT-FCT DONGGUAN THE FRIENDLY FAMILY 东莞硕能塑胶模具有限公司 ASSEMBLY AND MOULDING OF CLEANING							
LINE	ANGLE	-									
.xxx ±0.005	x ±2°	MATERIAL: -		APPROVED	CHECKED	DISGNE	REV.	A	PART NAME	IMOPXL.ABC.1407C-1 EXPLODED VIEW	FIRST ANGLE PROJECTION
.xx ±0.05	.x ±1.5°					CONNIE	UNIT	mm	PART NO	IMOPXL.ABC.1407C-1	SIZE
.x ±0.1	.xx ±1°						SCALE		PROJECT		A4
. ±0.2	.xxx ±0.5°										
xx ±0.5											
xxx ±1											
SHEET OF	DATE					26/Sep/2017					

Revision	Description	Revised	Date
A	FIRST RELEASE	CONNIE	26/Sep/2017

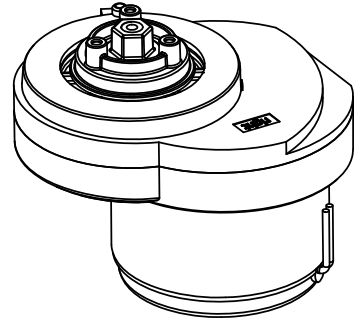
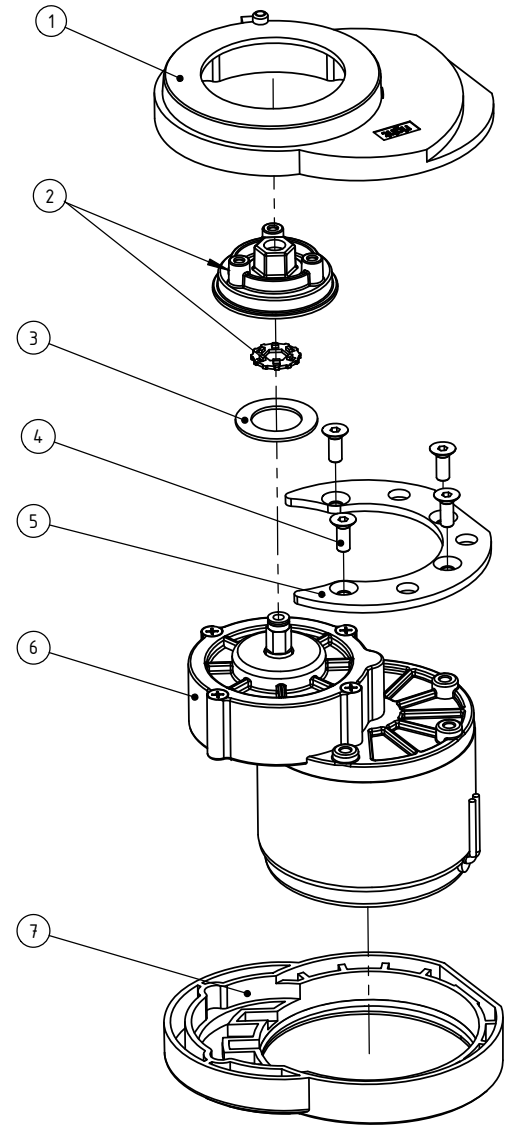

Item	P/N	Description	Qty.
	S.72.0000.1R	ASSY BRUSH MOTOR RIGHT	
1	72.0007.1	BRUSH MOTOR SUPPORT SUPPORT RUBBER RIGHT (MCH 1416-1001-2101)	1
2	72.0005.357/C	DRIVING WHEEL TOP WITH METAL INSERT (VER.1)	1
3	72.0004.0	FELT BRUSH MOTOR (MCH 1416-1001-2183)	1
4	72.0002.0N	NYLOK SCREW COUNTER SUNK BOLT M6X16 (MCH 1416-1001-2104)	4
5	72.0001.1	BRUSH MOTOR CONSTRUCTION RING RIGHT (MCH 1416-1001-2007)	1
6	72.0000.1R	BRUSH MOTOR HELICAL GEARS RIGHT	1
7	72.0006.1/A	BRUSH MOTOR FIXATION CONDUCTIVE RUBBER RIGHT	1
8	72.0108.0 NO SHOW	LOCKTITE 222	0.02
9	89.0469.2099.01 NO SHOW	SERTAL NO. BRUSH MOTOR RIGHT	1

TOLERANCES UNSPECIFIED <table border="1"> <thead> <tr> <th>LINE</th> <th>ANGLE</th> </tr> </thead> <tbody> <tr> <td>.xxx ±0.005</td> <td>x ±2°</td> </tr> <tr> <td>.xx ±0.05</td> <td>.x ±1.5°</td> </tr> <tr> <td>.x ±0.1</td> <td>.xx ±1°</td> </tr> <tr> <td>. ±0.2</td> <td>.xxx ±0.5°</td> </tr> <tr> <td>xx ±0.5</td> <td></td> </tr> <tr> <td>xxx ±1</td> <td></td> </tr> </tbody> </table>		LINE	ANGLE	.xxx ±0.005	x ±2°	.xx ±0.05	.x ±1.5°	.x ±0.1	.xx ±1°	. ±0.2	.xxx ±0.5°	xx ±0.5		xxx ±1		REMARK: - MATERIAL: -	SMT-FCT DONGGUAN THE FRIENDLY FAMILY 东莞硕能塑胶模具有限公司 ASSEMBLY AND MOULDING OF CLEANING	
LINE	ANGLE																	
.xxx ±0.005	x ±2°																	
.xx ±0.05	.x ±1.5°																	
.x ±0.1	.xx ±1°																	
. ±0.2	.xxx ±0.5°																	
xx ±0.5																		
xxx ±1																		
APPROVED	CHECKED	DISGNE	REV.	A	PART NAME	IMOPXL.ABC.1407C-1 EXPLODED VIEW												
		CONNIE	UNIT	mm	PART NO	IMOPXL.ABC.1407C-1		SIZE										
SHEET OF	DATE			26/Sep/2017	SCALE	PROJECT	A4											

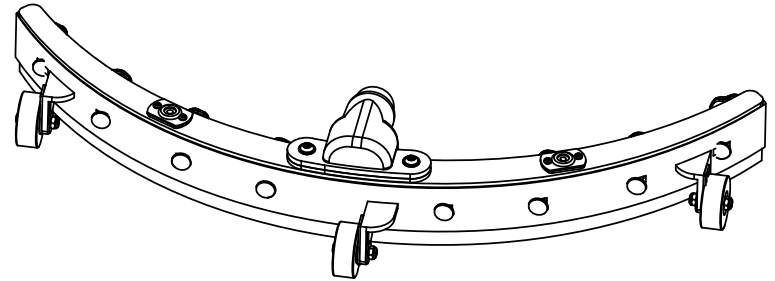
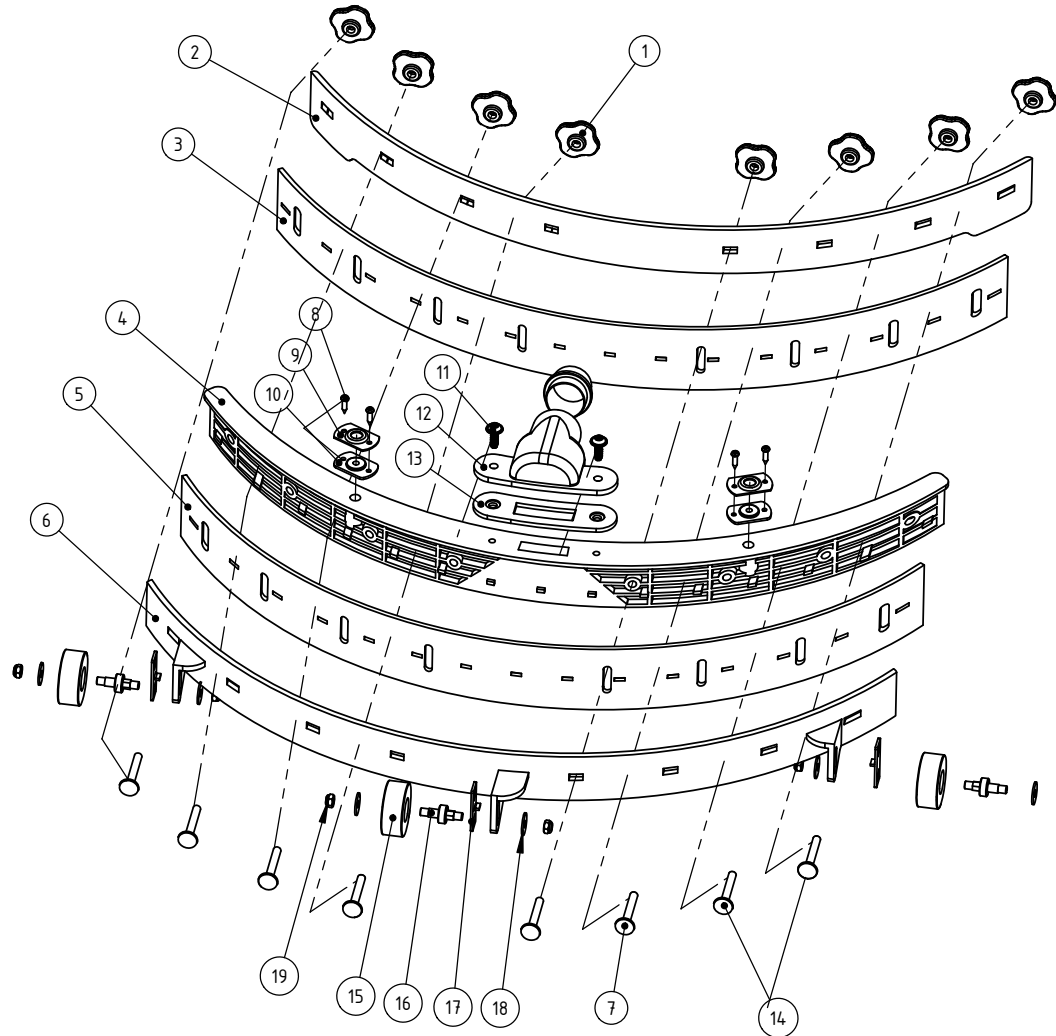

Item	P/N	Description	Qty.
	S.72.0096.0	SQUEEGEE ASSEMBLY (MCH 1416-1001-1006)	
1	72.0135.0	PLASTIC NUT SQUEEGEE	8
2	72.0097.0	SQUEEGEE FRONT PLATE [MCH 1416-1001-2068]	1
3	72.0099.0	SQUEEGEE FRONT RUBBER [MCH 1416-1001-2071]	1
4	72.0098.0	SQUEEGEE TOP PLATE [MCH 1416-1001-2069]	1
5	72.0100.2	SQUEEGEE REAR RUBBER [MCH 1416-1001-2070]	1
6	72.0096.0	SQUEEGEE REAR PLATE [WHEEL SIDE]	1
7	72.0136.0	M5 SCREW BOLT, THREAD LENGTH 35	4
8	85.1008.1	SCREW M3 X12 CROSSHEAD SELF TAPPING BL-NI,SST	4
9	72.0340.0	FIXATION PLATE SQUEEGEE PIN STAINLESS STEEL	2
10	72.0200.0/C	RUBBER WASHER FIXATION SQUEEGEE PIN BLAC	2
11	72.0026.0	SCREW WN 5451 50X14 EJOT DELTA PT	2
12	72.0103.8/C	SQUEEGEE HOSE CONNECTOR -UP YELLOW PP[C]	1
13	72.0102.0/A	SQUEEGEE HOSE CONNECTOR-SEALING GASKET	1
14	72.0136.1	M5 SCREW BOLT, THREAD LENGTH 30	4
15	72.0238.32	SQUEEGEE CASTOR GREY DIA.8MM	3
16	72.0137.2	SHAFT SQUEEGEE CASTOR DIA.8MM	3
17	72.0138.1	HEIGHT ADJUSTMENT PLATE [Ver1]	3
18	72.0235.0	M5 WASHER STAINLESS STEEL 5X15X1MM	6
19	04.0048.0	NUT M5 NYLON	6

TOLERANCES UNSPECIFIED		REMARK: -		SMT-FCT DONGGUAN THE FRIENDLY FAMILY 东莞硕能塑胶模具有限公司 ASSEMBLY AND MOULDING OF CLEANING					
LINE	ANGLE	MATERIAL: -							
.xxx ±0.005	x ±2°	APPROVED	CHECKED	DISGNE	REV.	A	PART NAME	IMOPXL.ABC.1407C-1 EXPLODED VIEW	
.xx ±0.05	.x ±1.5°			CONNIE	UNIT	mm	PART NO	IMOPXL.ABC.1407C-1	
.x ±0.1	.xx ±1°				SCALE		PROJECT		A4
. ±0.2	.xxx ±0.5°								
xx ±0.5									
xxx ±1									
SHEET OF	DATE			26/Sep/2017					

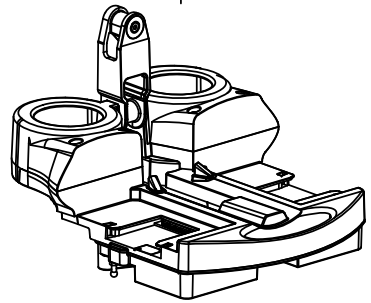
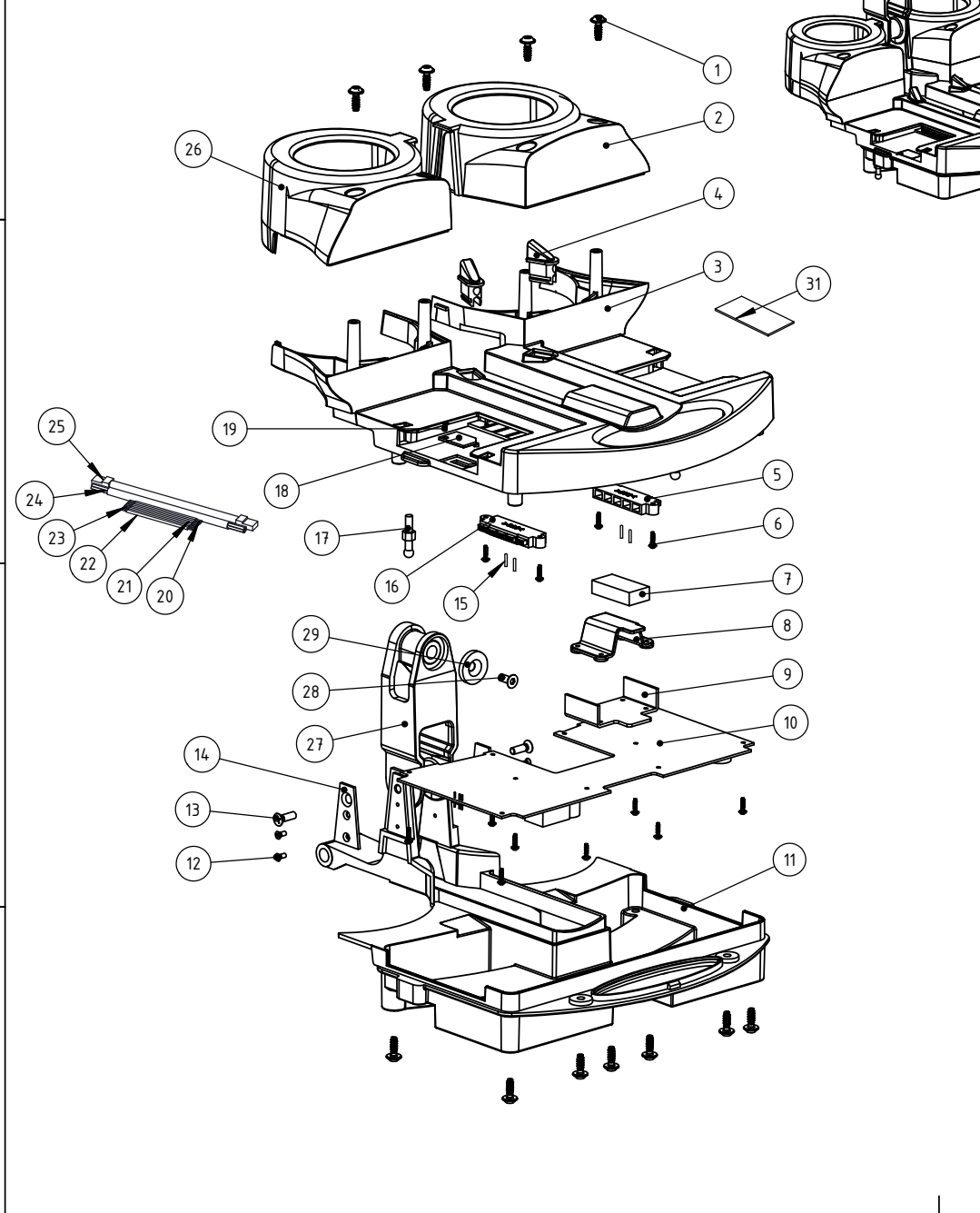

Item	P/N	Description	Qty.
	S.72.0065.2	ASSY MAIN LEVER UNIT IMOP (MCH 1416-1001-1004)	
1	72.0026.0	SCREW WN 5451 50X14 EJOT DELTA PT (MCH 1416-1001-2004)	12
2	72.0072.2	BRUSH WOTOR COOLING COVER RIGHT (MCH 1416-1001-2153), KLEUR	1
3	72.0065.2	MAIN LEVER COVER (MCH 1416-1001-2140), KLEUR, WHITE .2	1
4	72.0069.0	PCB MACHINE SEAL (MCH 1416-1001-2139)	2
5	72.0068.357	BATTERY CONNECTOR MALE Left:Blue, Right:Grey, Kleur: Grey	1
6	72.0057.0	SCREW WN 5451 25X10 EJOT DELTA PT (MCH 1416-1001-2150)	18
7	72.0051.0	MAGNET TOP UNIT 40X20X10mm (MCH 1416-1001-2044)	1
8	72.0067.357	MAGNET TOP UNIT HOLDER (MCH 1416-1001-2192), JKEYR: GREY.357	1
9	72.0219.0	STEEL COVER ISOLATION MAGNETIC T=3mm	1
10	72.1070.0/A	ASSY PCB LOCK CONNECTOR MACHINE BATTERY CONTROL XXL (BLUE)	1
11	72.0010.0/A	MAIN LEVER HOUSING (A)	1
12	72.0012.1N	NYLOK COUNTER SUNK BOLT M3X8, SST	4
13	72.0028.0N	NYLOK SCREW COUNTER SUNK BOLT M5X16	2
14	72.0011.0	MAIN LEVER SUPPORT PLATE (MCH 1416-1001-2193)	2
15	85.0050.1	ALIGNMENT PIN LONGER VERSION	4
16	72.0068.797	BATTERY CONNECTOR MALE LEFT: BLUE, RIGHT: GERY, KLEUR: BLUE	1
17	72.0071.0	SQUEEGEE FIXATION PIN (MCH 1416-1001-2158)	2
18	72.0164.2	COVER USB UPDATE SLOT, KLEUR: WHITE .2	1
19	72.0165.0	SCREW COUNTS SUNK M1.7X6	1
20	72.0123.0	MALE CONNECTOR + WIRES 14AWG RED 150MM	2
21	72.0124.0	MALE CONNECTOR + CONNECTOR WIRES 14AWG BLACK 150MM	2
22	72.0157.0/A	WIRES FOR BRUSH UNIT 14AWG BLACK ANGLE TERMINAL L=280mm	2
23	72.0157.1/A	WIRES FOR BRUSH UNIT 14AWG RED ANGLE TERMINAL L=280mm	2
24	72.0126.0/A	POWER CABLE 3 WIRES ANGLE TERMINALS [1.5MM2 L=630MM]	1
25	72.0125.0/D	UTP CABLE (MULTIPLE WIRES) RJ45 <-> YH2.0-8P CONNECTOR L=60C	1
26	72.0073.2	BRUSH MOTOR COOLING COVER LEFT [MCH 1416-1001-2154], Kleur:	1
27	S.72.0018.0	ASSY HINGE CARDAN [MCH 1416-1001-1011]	1
28	72.0033.2	COUNTER SUNK HEAD CAP SCREW M6X20 WITH NYLOK SCREW	1
29	72.0058.1	CARDAN DISK [Ver1]	1
30	72.0222.0	PET SHEET ONE SIDE 3M GLUE T=0.04MM	4
31	89.0467.2099.10	NO SHOW	
		STICKER IMOP [STRONG MAGNETS] [B]	1

TOLERANCES UNSPECIFIED		REMARK: -		SMT-FCT DONGGUAN THE FRIENDLY FAMILY 东莞硕能塑胶模具有限公司 ASSEMBLY AND MOULDING OF CLEANING			
LINE	ANGLE	MATERIAL: -		APPROVED	CHECKED	DISGNE	REV.
.xxx ±0.005	x ±2°					CONNIE	A
.xx ±0.05	.x ±1.5°					UNIT	mm
.x ±0.1	.xx ±1°					SCALE	mm
. ±0.2	.xxx ±0.5°					PROJECT	IMOPXL.ABC.1407C-1 EXPLODED VIEW
xx ±0.5						DATE	26/Sep/2017
xxx ±1						SIZE	A4
SHEET 10F 1		DATE		26/Sep/2017		SCALE	

1	2		3		4		5		6	
Revision	Description		Revised	Date						
A	FIRST RELEASE		CONNIE	26/Sep/2017						
				PAGE		18 / 22				

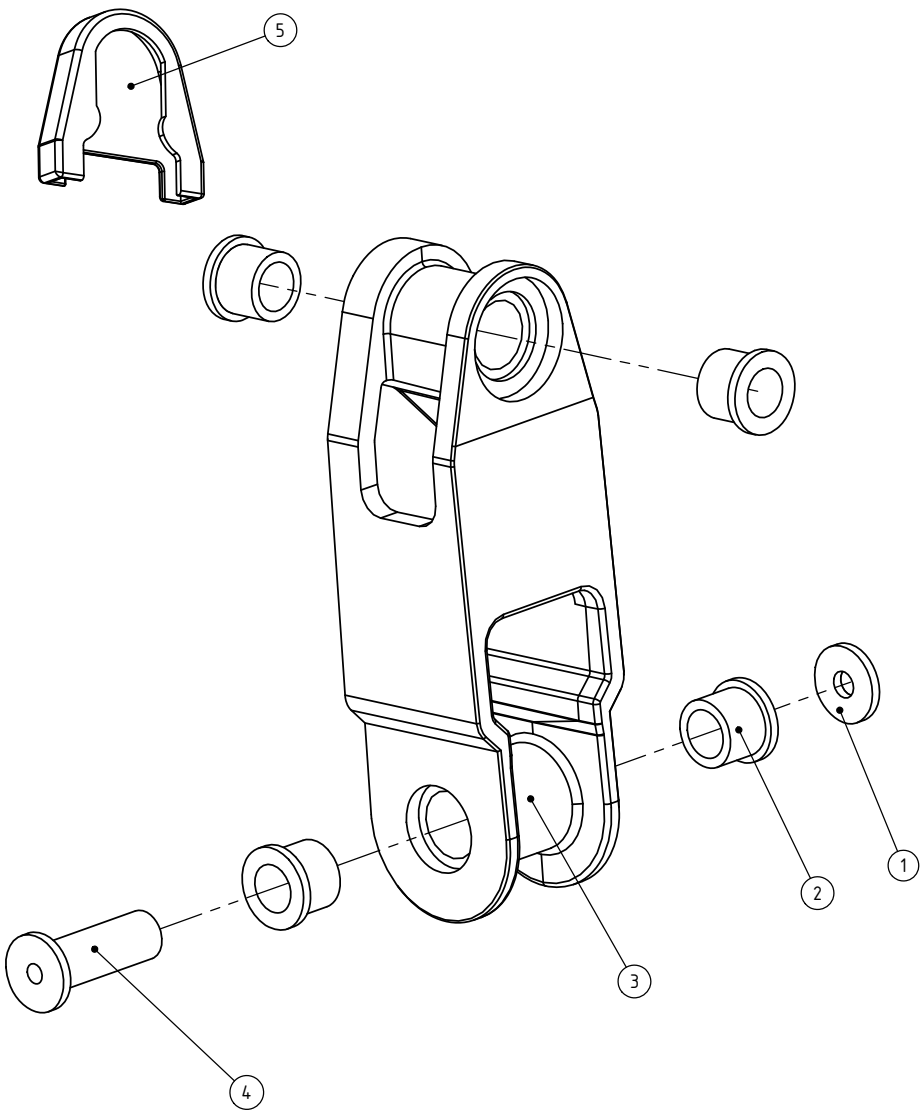

Item	P/N	Description	Qty.
	S.72.0018.0	ASSY HINGE CARDAN (MCH 1416-1001-1011)	
1	72.0020.0	WASHER AZIS MAIN LEVER (MCH 1416-1001-2116)	1
2	72.0016.0	BRUSHING AXIS 10 (MCH 1416-1001-2112)	4
3	72.0018.0	HINGE CARDAN TOP NUT (MCH 1416-1001-2029)	1
4	72.0019.0B	HINGE AXIS MAIN LEVER STAINLESS STEEL	1
5	72.0311.357	COVER HINGE SCREW, KLEUR: GREY .357 (P431C)	1

TOLERANCES UNSPECIFIED		REMARK: -		SMT-FACT DONGGUAN THE FRIENDLY FAMILY 东莞硕能塑胶模具有限公司 ASSEMBLY AND MOULDING OF CLEANING					
LINE	ANGLE	MATERIAL: -							
.xxx ±0.005	x ±2°	APPROVED	CHECKED	DISGNE	REV.	A	PART NAME	IMOPXL.ABC.1407C-1 EXPLODED VIEW	FIRST ANGLE PROJECTION
.xx ±0.05	.x ±1.5°			CONNIE	UNIT	mm	PART NO	IMOPXL.ABC.1407C-1	SIZE
.x ±0.1	.xx ±1°				SCALE	1:1	PROJECT		A4
. ±0.2	.xxx ±0.5°	SHEET 1 OF 1		DATE		26/Sep/2017			
xx ±0.5									
xxx ±1									

1		2		3		4		5		6	
Revision	Description			Revised	Date						
A	FIRST RELEASE			CONNIE	26/Sep/2017	PAGE 19 / 22					

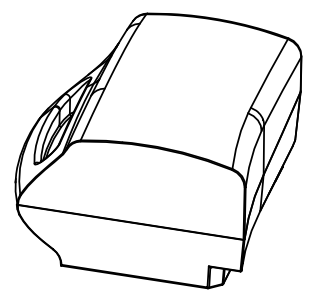
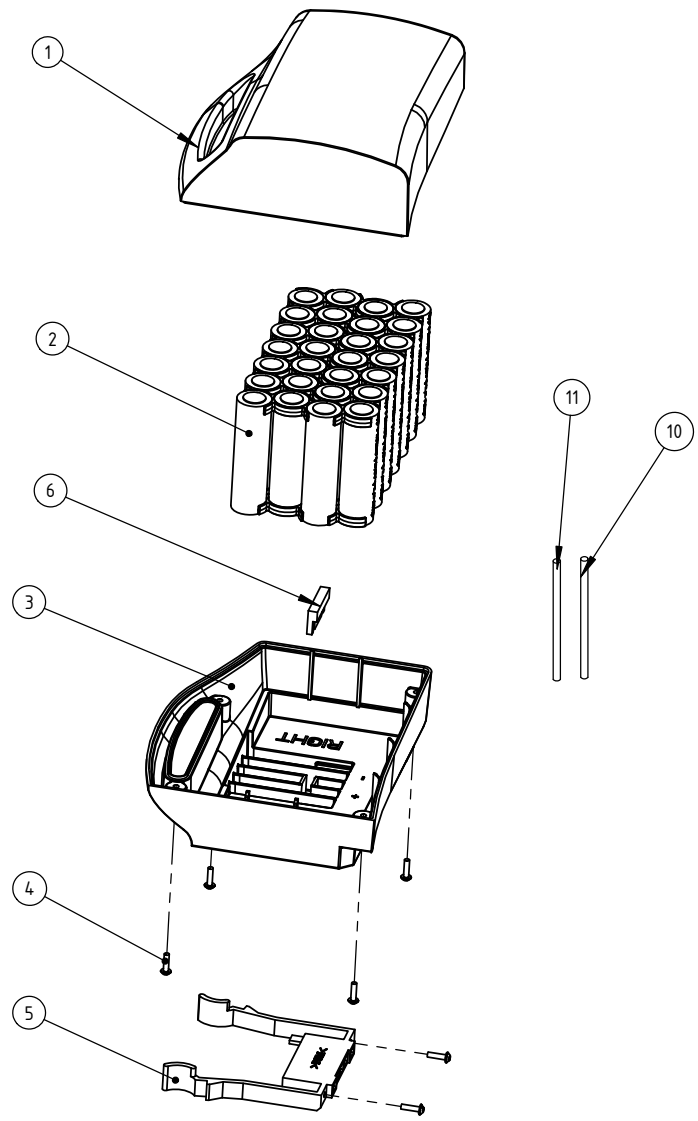

Item	P/N	Description	Qty.
	S.72.0079.2BSRA	ASSY BATTERY PACK GREY RIGHT BMS (FIRE RES) (W/O FUSE)	
1	72.0132.2R	BATTERY PACK HOUSING TOP RIGHT (FIRE RESISTANT)	1
2	72.0131.1/A	BATTERY PACK CELLS WITH BMS (8.8Ah) (W/O FUSE)	1
3	72.0079.2R	BATTERY PACK HOUSING BOTTOM RIGHT WHITE (FIRE RESISTANT)	1
4	72.0057.0	SCREW WN 5451 25X10 EJOT DELATA PT (MCH 1416-1001-2150)	6
5	72.0075.357	BATTERY CONNECTOR FEMALE, GREY, RIGHT (P431C)	1
6	72.0218.0	LIMITATION BLOCK FEMALE CONNECTOR	1
7	72.0170.0 NO SHOW	BUBBLE WRAP BAG 250x210	1
8	89.0469.2099.05 NO SHOW	SERIAL NO. BATTERY	1
9	89.0469.2099.07BM NO SHOW	STICKER SAFETY ADVISE FOR BATTERY RIGHT BMS	1
10	72.0129.0	BATTERY CONNECTOR + WIRES 14AWG, RED, L=250mm	1
11	72.1030.0	BATTERY CONNECTOR + WIRES 14AWG, BLACK, L=250mm	1

TOLERANCES UNSPECIFIED		REMARK:		SMT-FCT DONGGUAN THE FRIENDLY FAMILY 东莞硕能塑胶模具有限公司 ASSEMBLY AND MOULDING OF CLEANING	
LINE	ANGLE	-			
.xxx ±0.005	x ±2°	MATERIAL: -		APPROVED	CHECKED
.xx ±0.05	.x ±1.5°			DISGND	REV.
.x ±0.1	.xx ±1°			CONNIE	UNIT
. ±0.2	.xxx ±0.5°			mm	PART NAME
xx ±0.5				IMOPXL.ABC.1407C-1 EXPLODED VIEW	IMOPXL.ABC.1407C-1
xxx ±1				SCALE	1:1
SHEET OF		DATE		PROJECT	
		26/Sep/2017		A4	

Revision		Description		Revised	Date	PAGE		20 / 22	
A		FIRST RELEASE		CONNIE	26/Sep/2017				

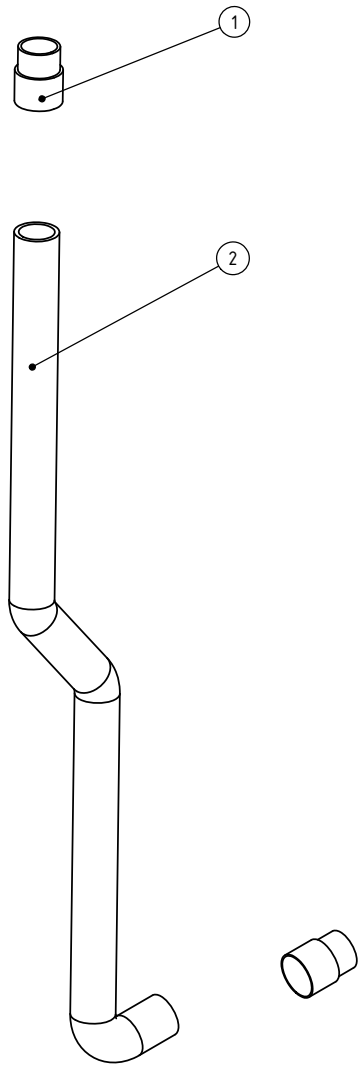

Item	P/N	Description	Qty.
	S.72.0094.0	STRETCH HOSE COMPLETE	
1	72.0095.8	STRETCH HOSE CUFF YELLOW	2
2	72.0094.0	STRETCH HOSE TOP UNIT [MCH 1416-1001-2098]	1

TOLERANCES UNSPECIFIED		REMARK: -		SMT-FCT DONGGUAN THE FRIENDLY FAMILY 东莞硕能塑胶模具有限公司 ASSEMBLY AND MOULDING OF CLEANING					
LINE	ANGLE	MATERIAL: -							
.xxx ±0.005	x ±2°	APPROVED	CHECKED	DISGNED	REV.	A	PART NAME	IMOPXL.ABC.1407C-1 EXPLODED VIEW	
.xx ±0.05	.x ±1.5°			CONNIE	UNIT	mm	PART NO	IMOPXL.ABC.1407C-1	SIZE
.x ±0.1	.xx ±1°				SCALE		PROJECT		A4
. ±0.2	.xxx ±0.5°								
xx ±0.5									
xxx ±1									
SHEET 1 OF 1	DATE			26/Sep/2017					

1	2		3		4		5		6	
Revision	Description		Revised	Date						
A	FIRST RELEASE		CONNIE	26/Sep/2017						
				PAGE		21 / 22				

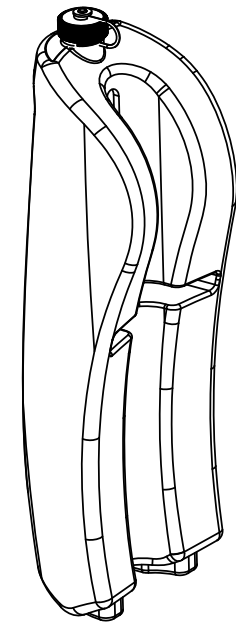
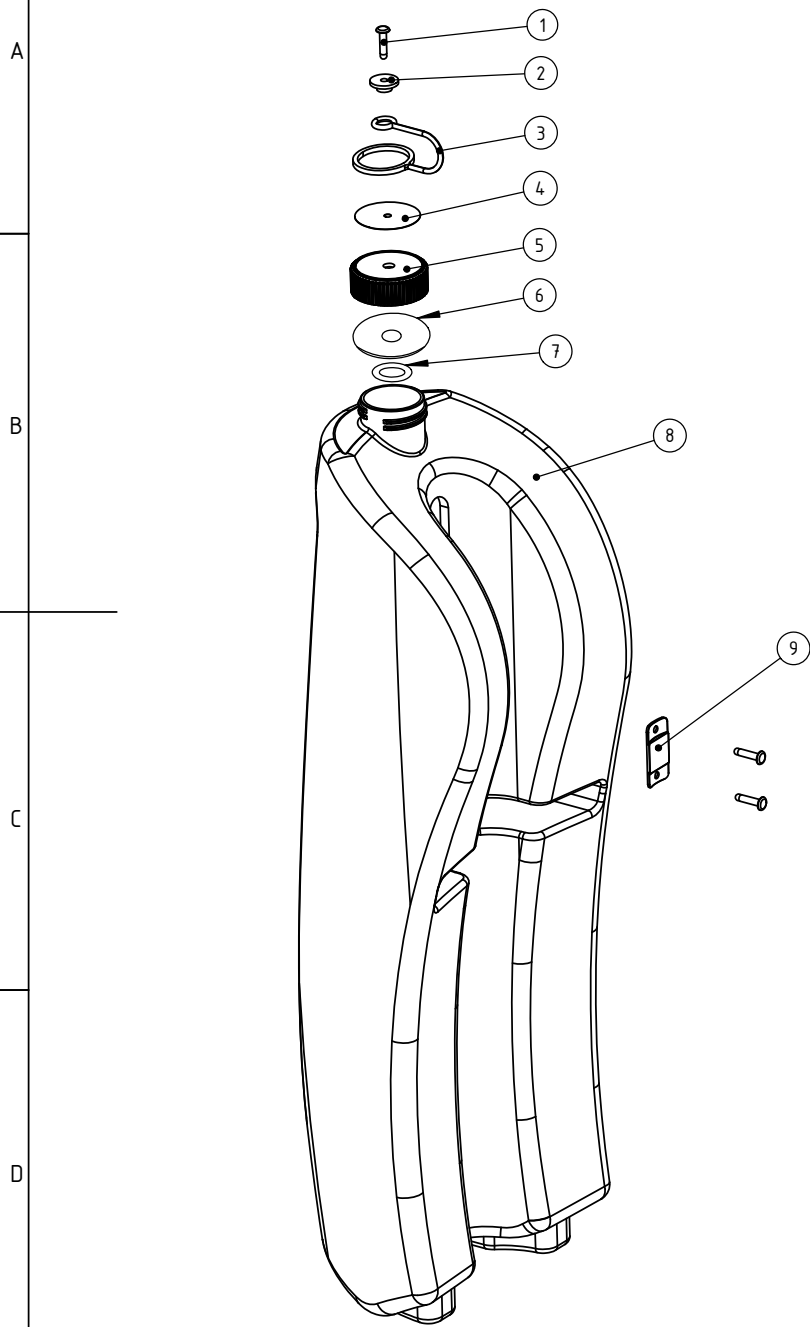

Item	P/N	Description	Qty.
	S.72.0088.1	DIRT COMPARTMENT	
1	54.0029.0	BLIND REVIT NAIL 4X15mmg	3
2	72.0254.0	SLEEVE CAP HOLDER	1
3	72.0252.0	CAP HOLDER	4
4	89.0469.2099.25A	WARNING PLATE ON DIRTY TANK ROUND STAINLESS PLATE 4.5mm	1
5	72.0264.357	CAP WITHOUT HOLE COLOR: GREY (P431C)	1
6	72.0265.0	SEALING GASKET CAP DIRTY TANK	1
7	72.0271.0	PLASTIC WASHER 9x4x1mm	1
8	72.0088.1	DIRT COMPARTMENT, CAP VERSION	1
9	72.0089.0	FIXATION PLATE DIRT COMPARTMENT (MCH 1416-1001-2171)	1

TOLERANCES UNSPECIFIED		REMARK:		SMT-FCT DONGGUAN THE FRIENDLY FAMILY 东莞硕能塑胶模具有限公司 ASSEMBLY AND MOULDING OF CLEANING							
LINE	ANGLE	-									
.xxx ±0.005	x ±2°	MATERIAL: -		APPROVED	CHECKED	DISGNE	REV.	A	PART NAME	IMOPXL.ABC.1407C-1 EXPLODED VIEW	
.xx ±0.05	.x ±1.5°					CONNIE	UNIT	mm	PART NO	IMOPXL.ABC.1407C-1	SIZE
.x ±0.1	.xx ±1°						SCALE	1:1	PROJECT		A4
. ±0.2	.xxx ±0.5°										
xx ±0.5											
xxx ±1											
SHEET OF	DATE					26/Sep/2017					

1	2		3		4		5		6	
Revision	Description		Revised	Date						
A	FIRST RELEASE		CONNIE	26/Sep/2017						
				PAGE		22 / 22				

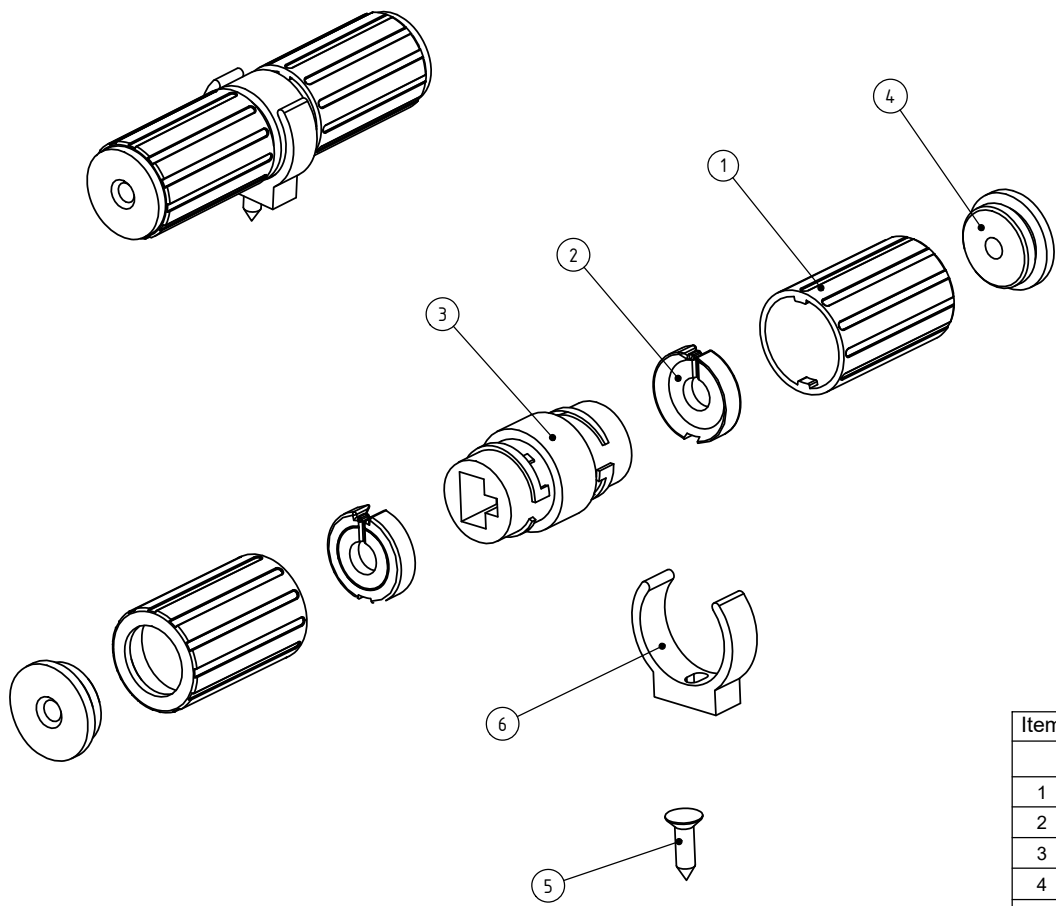

Item	P/N	Description	Qty.
	S.72.0243.0	ASSEMBLY SIGAR UTP CONNECTOR	1
1	72.0244.797/A	COVER UTP CONNECTOR JOINT COLOR: BLUE (P312C) (A)	2
2	72.0245.797	SUPPORT PLATE SIGAR UTP CONNECTOR COLOR: BLUE (P312C)	2
3	72.0243.0	SIGAR UTP CONNECTOR	1
4	72.0246.0	SEALING RING SIGAR UTP CONNECTOR	2
5	72.0240.0	COUNT SUNK SCREW M3.5X13 PHILPS HEAD	1
6	72.0247.0/A	CLIP PLASTIC IN WHIRE WIDTH: 7mm	1

TOLERANCES UNSPECIFIED		REMARK: -		<p style="text-align: center;">SMT-FACT DONGGUAN THE FRIENDLY FAMILY 东莞硕能塑胶模具有限公司 ASSEMBLY AND MOULDING OF CLEANING</p>					
LINE	ANGLE	MATERIAL: -							
.xxx ±0.005	x ±2°	APPROVED	CHECKED	DISGNE	REV.	A	PART NAME	IMOPXLABC.1407C-1 EXPLODED VIEW	FIRST ANGLE PROJECTION
.xx ±0.05	.x ±1.5°			CONNIE	UNIT	mm	PART NO	IMOPXL.ABC.1407C-1	SIZE
.x ±0.1	.xx ±1°				SCALE		PROJECT		A4
. ±0.2	.xxx ±0.5°								
xx ±0.5		SHEET OF	DATE			26/Sep/2017			
xxx ±1									