

# Clemas & Co Ltd

Industrial Cleaning Equipment  
Sales - Hire - Service

## i-cover Operator Manual



**Clemas & Co.** Unit 16 Ashchurch Business Centre, Alexandra Way, Tewkesbury,  
Gloucestershire, GL20 8NB.

**Tel:** 01684 850777

**Fax:** 01684 850707

**Email:** [info@clemas.co.uk](mailto:info@clemas.co.uk)

**Web:** [www.clemas.co.uk](http://www.clemas.co.uk)



i-cover 1.0

---

## INSTRUCTION MANUAL

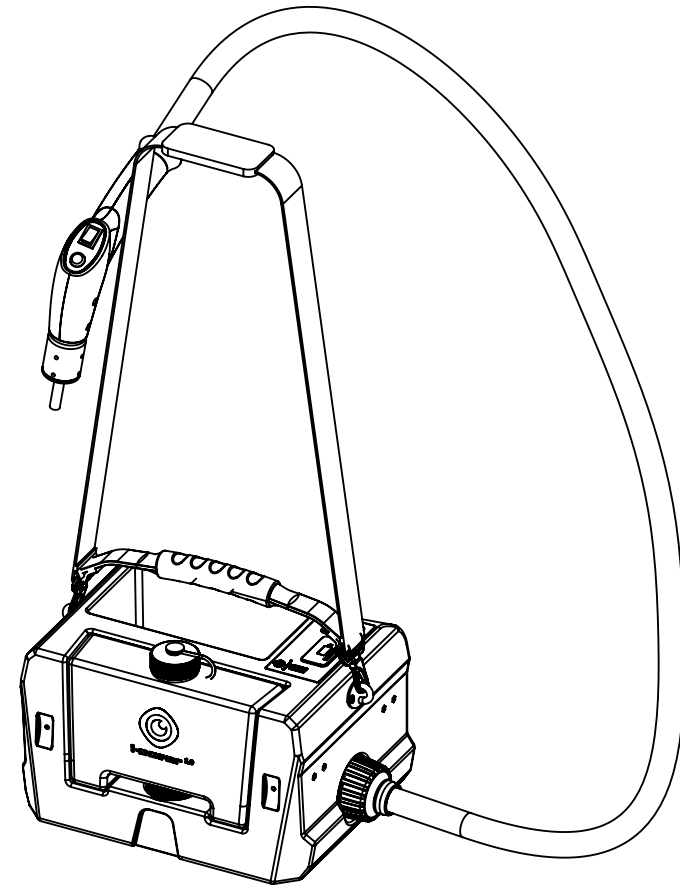

Thank you for purchasing the i-cover 1.0 cold spray misting system: The powerful, easy to use system that can cover your surfaces in seconds. We have made disinfecting surfaces easy when you combine your favourite disinfectant and our simple color coded nozzle system. Due to the 24V li-ion battery and swappable tanks, you can keep disinfecting all day long. The i-cover 1.0 is easy to use when you follow the instructions. Please read the user manual carefully. Become familiar with the correct operation and maintenance procedures. Store the manual in a safe place. The manual is an essential part of the i-cover 1.0 system and must be handed over to the new owner upon resale or exchange. When this manual refers to "the manufacturer" this means: Future Cleaning Technologies B.V. in Eindhoven, The Netherlands. When this manual mentions "the dealer" your local i-team sales and support dealer is referred to.

## Purpose of the user manual

The purpose of the user manual is to provide the user with information during the life of the i-cover in such a way that the i-cover is used correctly, efficiently and safely, even in the event of reasonably foreseeable misuse.

The user manual contains instructions regarding:

- Personal operator safety
- Intended and nonintended use of the i-cover
- Instructions for daily use
- Maintenance instructions
- Storage conditions
- Disposal of the i-cover

These instructions must be taken into account to avoid risks that could lead to physical and/or material damage.

## Target audience

This user manual is intended for operators of the i-cover and their supervisors, as well as dealers and importers.

## Operators of the i-cover

The i-cover may only be operated by person who:  
has correctly read and understood the instructions in this manual.  
is trained by an experienced operator who has read and understood the instructions in this manual.

# Maintenance

The machine requires very little maintenance. Wipe down the machine periodically with a clean cloth. And wipe down the lance, and change the new brush for the lance. DO NOT spray water directly over the top of machine or top connector cap.

1. During interruptions of the cleaning process, always place the lance into the holder of body. And always place the machine upright on dry floor surface.
2. When the water drop disk is full, please empty and wash it, and then install back to body.
3. The cap of tank must be closed during operation, when you finish the fluid input. Otherwise dirt will infect the water tank.



DO NOT put any other fluid into the tank unless approved by the manufacturer.



4. Make sure the batteries are charged 100% on the first charge.
5. It is advised to flash the spray nozzle with water when you are finished disinfecting for the day to avoid a clogged nozzle.

## Instruction for control panel

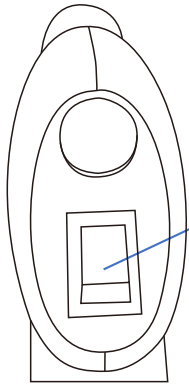

Switch  
After turn on the main switch on control panel, turn on this switch then machine will work.

## Turn off the machine

1. turn off switch on handle.
2. turn off main switch on main body.

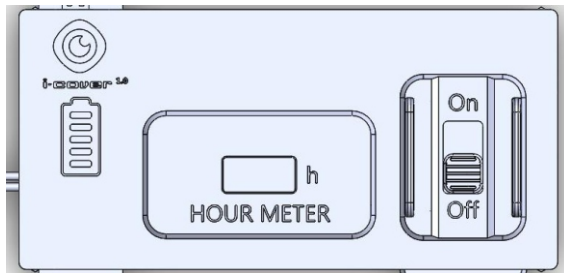
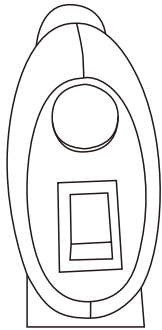

3. take off the battery and charge it.

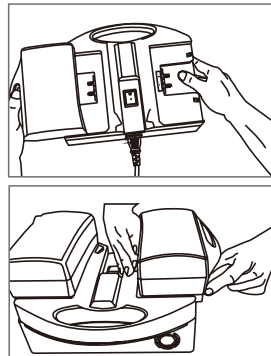
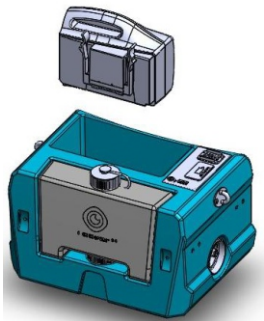

## Reading guide

The following symbols and terms are used throughout this manual to alert the reader to safety issues and important information:

	WARNING	Indicates a hazardous situation which, if the safety instructions are not followed, can lead to injuries of the operator or bystanders, light and/or moderate damage to the product or the environment.
	STRONG MAGNET	Indicates the machine contains strong magnets. These can cause pacemakers to stop or cause electronic data to be damaged, for instance on information stored on access passes.
	PACEMAKER	Indicates operators and maintenance crew wearing pacemakers should keep a minimal distance of 6 inch/15 cm. In this specific case operators may not use the machine as a backpack.
	BATTERIES	Indicates a battery operated machine, batteries must be charged according to the instructions in the separate Class I Battery Charger user manual. Batteries must be disposed of according to your local laws and regulations
	PROTECTIVE EYEWEARE	Indicates protective eyewear is advised, for instance when filling the machine with cleaning solution
	WASH HANDS	Indicates the operator is advised to wash their hands, for instance after filling and/or draining the cleaning solution.
	HOT SURFACE	Indicates hot surfaces of parts of the machine. Hot surfaces can cause burns in contact with skin over longer time.
	SLIPPERY SURFACE	Indicates the machine can cause floors to become slippery. Marking the workplace with slippery surface signs is advised.

# CONTENTS

Preface	02
Purse of the user manual	02
Target audience	02
Reading guide	03
Important Safety Instructions	05~06
Package Check List	06~07
Product description	07
Preparation of operation	08
Operation	08~09
Instruction for control panel	10

## Operation

3. Make sure the main power switch is in the off position  
Insert the battery. Switch on the main power switch .  
The machine is now ready for use.

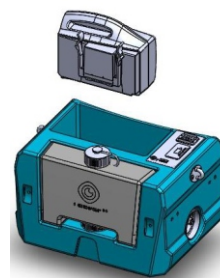

## Instruction for control panel

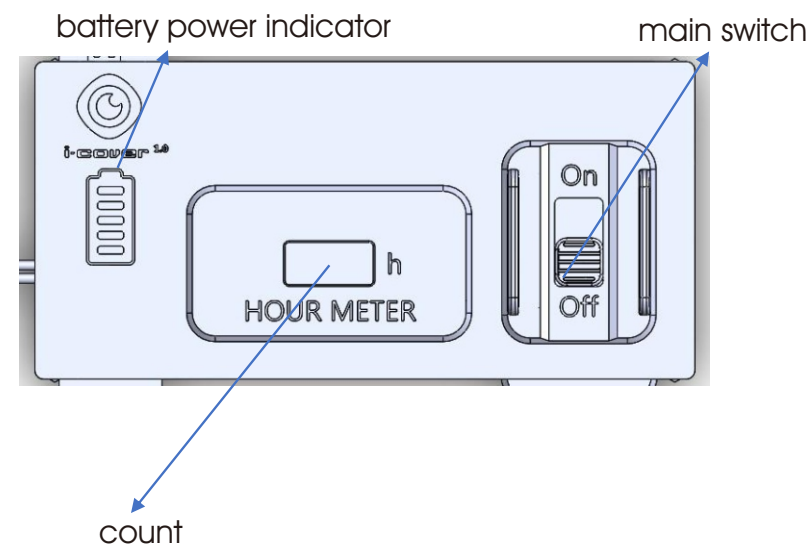

the count is counting by 6 mins/cycle,so 1 means 6 mins,  
and the two dots flash means the machine is working,  
flash time is 1s/cycle.

## Before operating the machine:

Ensure that the battery has been fully charged before each operation.

Before you charge the battery, please read the INSTRUCTION MANUAL OF BATTERY CHARGER first. The manual is in the package of the charger box. please keep the manual.

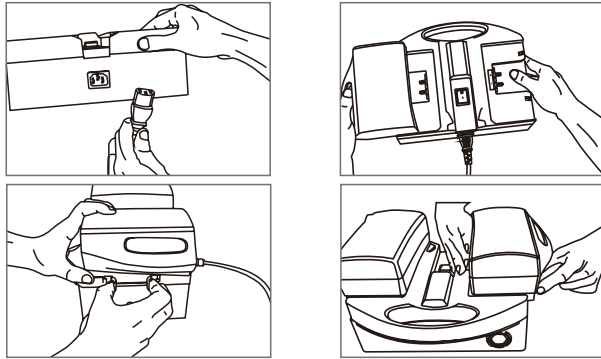

## Operation

1. fill tank with solution and assemble it on main body.

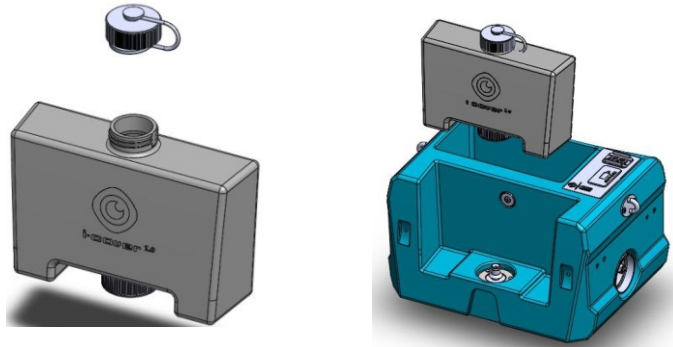



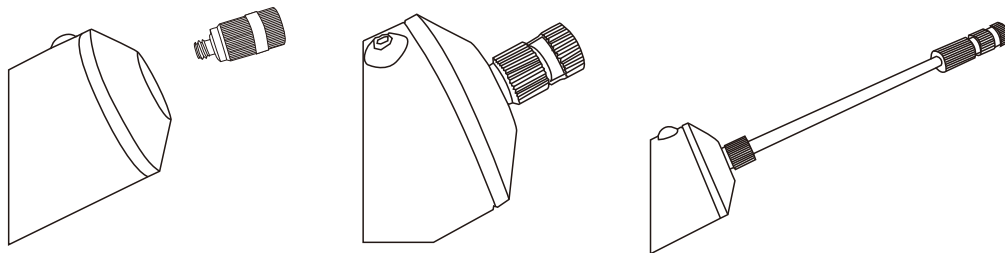

2. assemble nozzle on handle, choose spray nozzle according to your requirement, install it on nozzle head. You can also use the extend tube to increase your spray range.



## IMPORTANT SAFETY INSTRUCTIONS

### READ ALL INSTRUCTIONS BEFORE USING THIS MACHINE

 <b>i-cover</b>  <b>Warning!</b>  READ ALL INSTRUCTIONS BEFORE USING THE MACHINE	  <b>Warning!</b> Maintenance/service people (not i-cover operators) need to keep a distance to the integrated magnets in i-cover for 6 inch/15 cm when they are doing maintenance on i-cover and are wearing a pacemaker,  this is just a precaution advise  	 <b>i-cover</b> LITHIUM-ION BATTERY Nominal Voltage:24V Energy/Capacity: 353 Wh”  <b>SAFETY ADVICE</b> Do not crush, pierce or damage in any way. Do not heat or incinerate. Do not short-circuit. Do not dismantle. Do not immerse in any liquids. Only charge between 5°C~40°C/41°F~ 104°F and discharge 5 C~45 C/41 F~113 F  
--	---	--

DO NOT OPERATE THE MACHINE WITHOUT READING AND UNDERSTANDING THE OPERATING INSTRUCTIONS. IF THE MACHINE IS OPERATED INCORRECTLY IT CAN POSE DANGER TO THE OPERATOR AND OTHERS AND WILL INVALIDATE THE MANUFACTURERS WARRANTY. BEFORE USE, READ AND UNDERSTAND THE FOLLOWING:

1. A Risk Assessment for the works to be undertaken.
2. MSDS Chemical Data Sheet.
3. Risk Assessment for Chemical use.





#### IMPORTANT NOTICE:

Before inserting the batteries, correctly the machine to the operator and adjust the straps as required. The machine's body has been designed to be kept upright at all times when the batteries are inserted to drawer. This is important to the operation of the machine.

# IMPORTANT SAFETY INSTRUCTIONS

## READ ALL INSTRUCTIONS BEFORE USING THIS MACHINE

Cautions when using the machine: 

-  Keep the body upright at all times when operation or when chemical or batteries inserted.
-  The rechargeable battery has been designed to be fully charged BEFORE each use.
-  Only use the approved solution and batteries for the safe use of the machine. Using other consumable items in the machine invalidated the warranty and will lead to damage of the internal parts of the machine and also may pose a risk to the operator.
-  Make sure the operator has read and understood these instructions before attempting to use the machine and is fully trained in its operation.

### Warranty:

The i-cover machine should only be operated with the service packs supplied. Using alternative supplies may cause damage to the machine and cause a risk to the operator. Using alternative supplies voids manufacturer's warranty.

## Package Check list:

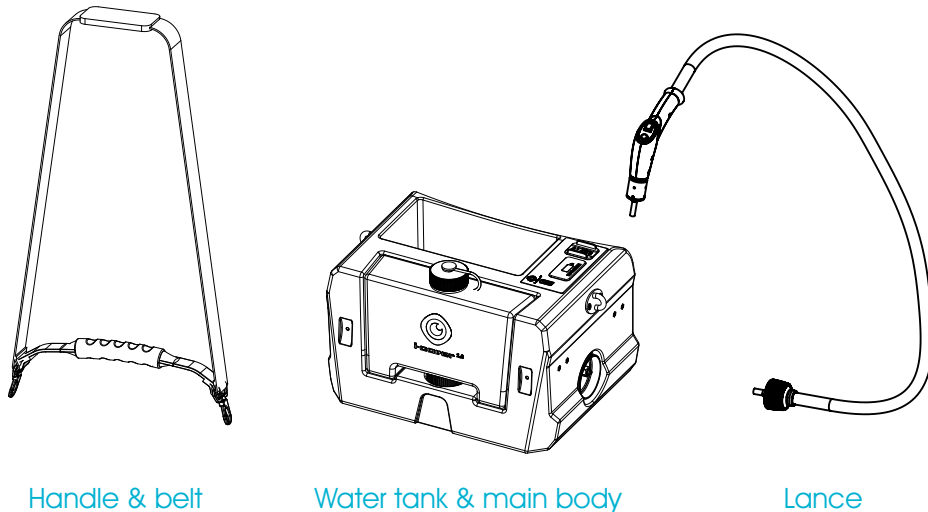

## Package Check list:

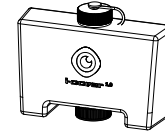

1 extra tank

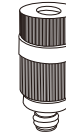

Nozzle  
0.3mm x1 green ring  
0.5mm x1 orange ring  
0.8mm x1 blue ring



Extend tube  
105mm x1

### Accessory:

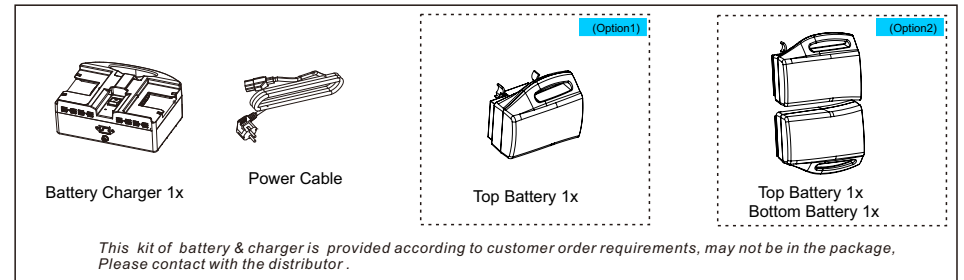

## Product Description

