

Clemas & Co Ltd

Industrial Cleaning Equipment
Sales - Hire - Service

i-move 2.5B Operator Manual



Clemas & Co. Unit 16 Ashchurch Business Centre, Alexandra Way, Tewkesbury,
Gloucestershire, GL20 8NB.

Tel: 01684 850777

Fax: 01684 850707

Email: info@clemas.co.uk

Web: www.clemas.co.uk



Preface

Thank you for purchasing the i-move 2.5B®. The cordless i-move 2.5B with its lightweight backpack, gives you more freedom of movement, especially in confined areas. There is no longer a need to worry about difficult terrain with bumps, steps, or other obstacles.

The i-move 2.5B is easy to use when you follow the instructions. Please read the user manual carefully. Become familiar with the correct operation and maintenance procedures. Store the manual in a safe place. The manual is an essential part of the i-move 2.5B and must be handed over to the new owner upon resale or exchange. Each i-move 2.5B has a unique identification number that can be found on top of the main body. Your i-team partner needs this number when you order parts.

When this manual refers to “the manufacturer” this means: Future Cleaning Technologies B.V., an affiliate company of i-team in Eindhoven, the Netherlands. When this manual mentions “the partner” your local i-team resell and support service partner is referred to.

Purpose of the user manual

The purpose of the user manual is to provide the user with information during the life of the i-move 2.5B in such a way that the i-move 2.5B is used correctly, efficiently and safely, even in the event of reasonably foreseeable misuse.

The user manual contains instructions regarding:

- personal operator safety;
- intended and non-intended use of the i-move 2.5B;
- instructions for daily use;
- maintenance instructions;
- storage conditions;
- disposal of the i-move 2.5B.

These instructions must be considered to avoid risks that could lead to physical and/or material damage.

Target audience

This user manual is intended for operators of the i-move 2.5B and their supervisors, as well as partners and importers.

Operators of the i-move 2.5B





The i-move 2.5B may only be operated by a person who:

- has correctly read and understood the instructions in this manual;
- is trained by an experienced operator who has read and understood the instructions in this manual.



Reading guide

The following symbols and terms are used throughout this manual to alert the reader to safety issues and important information:

Symbol	Term	Explanation
	WARNING	Indicates a hazardous situation which, if the safety instructions are not followed, can lead to injuries of the operator or bystanders, light and/or moderate damage to the product or the environment.
	CAUTION	Indicates a hazardous situation which, if the safety instructions are not followed, can lead to light and / or moderate damage to the product or the environment.
	BATTERIES	Indicates a battery-operated machine, batteries must be charged according to the instructions in the separate Class I Battery Charger user manual. Batteries must be disposed of according to your local laws and regulations.
	ATTENTION	Indicates a liability situation, where the manufacturer or its partners and affiliates cannot be held accountable for damages caused by non-compliance.



Content

Preface	3
Purpose of the user manual	3
Target audience	3
Operators of the i-move 2.5B	3
Reading guide.....	4
1 Introduction.....	7
1.1 Intended use of the product.....	7
1.2 Non-intended use of the product.....	8
1.3 Lifespan.....	8
1.4 Modifications.....	8
1.5 Specifications.....	9
1.6 Warranty.....	10
1.7 Identification	11
2 Description	12
2.1 The remote control.....	13
3 Safety.....	14
3.1 General Safety Instructions	14
3.2 Batteries	14
3.3 Risks during operation.....	14
4 Transport and storage	15
5 Assembly and installation.....	16
5.1 Unboxing.....	16
5.2 Assembly.....	17
5.3 Replacing the dust bag	18
6 Operation	20
6.1 Before you start	20
6.1.1 Height adjustment.....	20
6.1.2 Insert the battery	20
6.2 Normal operation	21
6.2.1 After normal operation	23
6.2.2 Remove the battery	23
6.3 Operation with i-brush®	24
6.3.1 After operation with i-brush®	27
6.3.2 Remove the battery	27
7 Maintenance	28



7.1	Cleaning	28
7.1.1	Cleaning the machine	28
7.1.2	Cleaning the hose and wand	28
7.1.3	Cleaning the filters	28
7.2	Replacing the filters	29
7.2.1	Replacing the cassette filter	29
7.2.2	Replacing the motor filter	31
7.2.3	Replacing the fragrance cartridge	32
7.3	Brush and tool condition	33
7.4	Damaged or worn parts	33
7.5	Maintenance frequency	33
7.6	Storage.....	33
8	Trouble shooting	34
9	Decommissioning and disposal	35
10	Attachments	36
10.1	CE Certificate	36



1 Introduction

The i-move 2.5B® is an easy and safe machine to use. This manual helps you get started and explains the operation and maintenance procedure.

The battery must be fully charged before use. Please refer to the user manual of the i-charge® 5 for the correct procedure.

This manual is intended for those who work with the i-move 2.5B and perform daily maintenance. The manual must be read in full before the first actions. This manual describes the correct method of use, safety measures, maintenance and transport.

i-team continuously improves all their products based on user experience and feedback. Any deviations between the texts and/or images from the manual and your i-move 2.5B can therefore arise from the difference in model or from possible changes due to continuous development and innovation.

1.1 Intended use of the product

The i-move 2.5B is intended for indoor use for the collection of **dry** materials only.

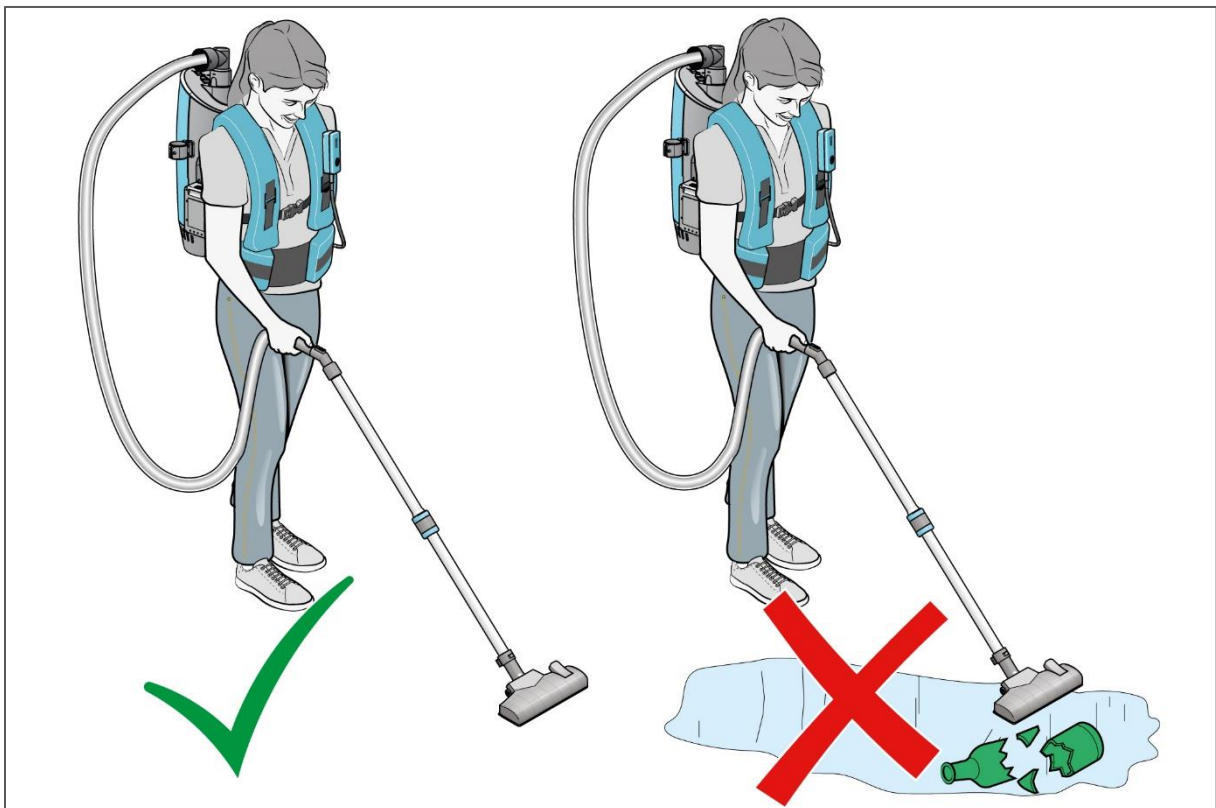

Figure 1

The lightweight i-move 2.5B is specially developed to use in small spaces. For example: in hotel rooms, classrooms, hospital rooms, shops, offices and also stairs.



Make sure that the i-move 2.5B® is maintained as described in section 7. Not following the recommended maintenance may lead to hazardous situations and i-team Professional may NOT give warranty.

Check the filters, brushes and the hose regularly for pollution or damage. Replace damaged parts. For more information on how to order i-move 2.5B parts, please see section 7.4.

ONLY USE original i-team Professional parts! i-team Professional does NOT give warranty in case non original parts are used.

Operation of the i-move 2.5B must be done by an adult person.

Keep the i-move 2.5B and the accessories clean.

In order to use the i-move 2.5B on different types of surfaces, besides the standard floor tool, also a crevice tool, an upholstery tool and a round brush are available. These tools are easy to replace. Select the right tool for each job.

1.2 Non-intended use of the product



WARNING

Non-intended use can have consequences for the safety of operators and bystanders and will void the warranty on the product.

The i-move 2.5B is not intended to clean anything else but dry materials.

The i-move 2.5B is not suitable for the collection of:

- wet materials or water;
- hot ashes or lighted cigarette ends;
- hazardous or explosive substances;
- biological hazards;
- particulate matter;
- big pieces of glass, plastic or wood.

1.3 Lifespan

For a proper functioning and a long lifespan of the i-move 2.5B, it is important to follow the recommended maintenance frequency mentioned in this manual.

1.4 Modifications

It is not permitted to make modifications to the design of the i-move 2.5B without consultation and permission from the manufacturer. This affects the warranty, see section 1.6.



1.5 Specifications

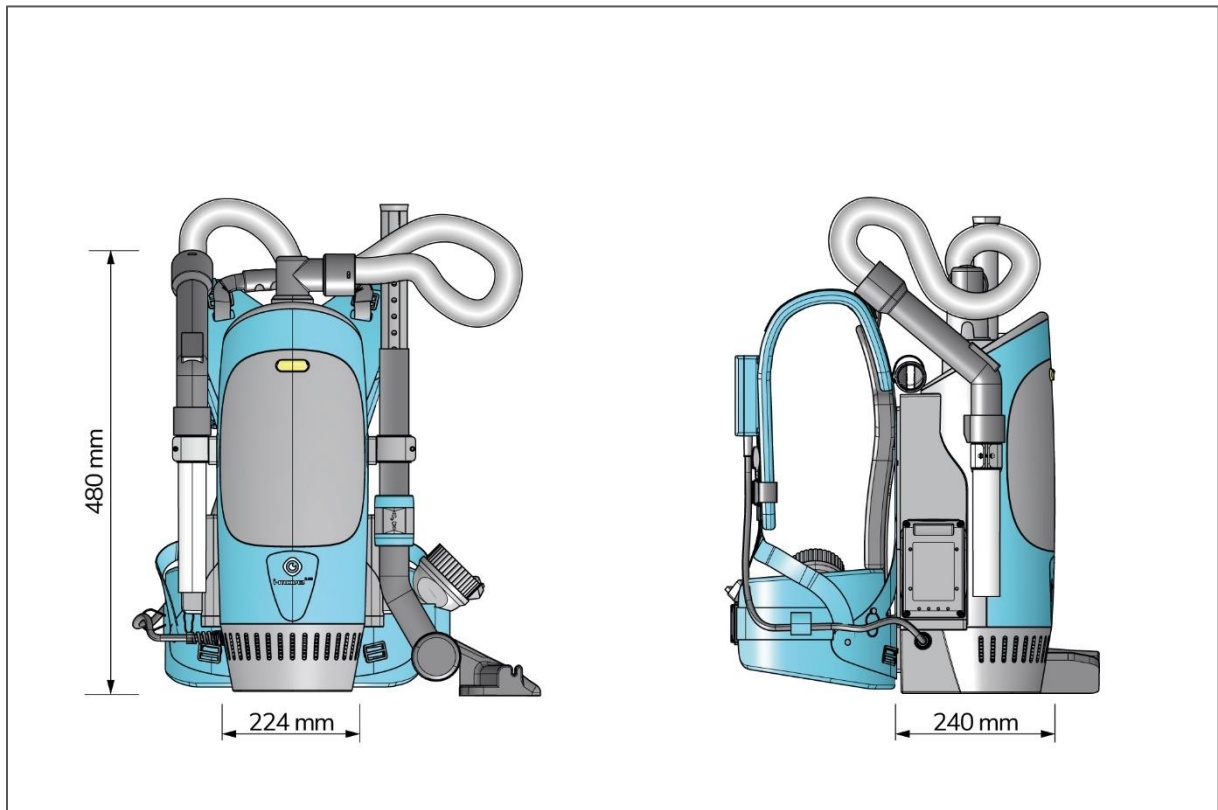

Figure 2

Body size excluding harness (W x T x H):	224 x 240 x 480 mm
Weight (excl. hose and wand, incl. batteries):	5.28 kg
Battery weight (1 battery):	0.70 kg
Hose length (retracted/stretched out):	50 cm/200 cm
Capacity:	2.5 L
Sound level (1 m distance and 1 m distance on 1.5 m height):	77.5 dB(A)/ 72.7 dB(A)
Vibration (main body/handle):	Amplitude: 0.004/0.004 mm Velocity: 0.3/0.7 m/s Acceleration: 1.5/0.8 m/s ²
Diameter of tools:	32 mm
Suction (200 gr. salt, full charging, area surface 1.5 x 1 m, test time 2 min.):	Net weight of suction (gr.): 189/159/184 Suction rate (%): 94.5/79.5/92
Motor:	250 W/28 V/9.6 Ah
Air flow (max.):	1.75 m ³ /sec
Application:	Indoor, dry
Power source:	i-power 8.7 battery
Battery spec i-power x:	14.4 V 8.7 Ah
Run time:	≈ 56 minutes
Charger type:	External
Material outer shell:	ABS
Material hose:	ESD



1.6 Warranty

The i-move 2.5B[®] should only be operated with the materials supplied. Using alternative supplies may cause damage to the i-move 2.5B and may cause a risk to the operator. The use of alternative supplies voids manufacturer's warranty. The warranty period is 1 year.



1.7 Identification

Each i-move 2.5B® has a unique serial number that can be found on the bottom of the main body. Your i-team partner needs this number when you order parts.

Explanation type plate:



Figure 3

Product type: i-move 2.5B

Serial number:

Current: 28V/power 240 W

Distributor:
i-team Professional
Hoppenkuil 27 b
NL-5626 DD Eindhoven



2 Description

The unique carrying system of the i-move 2.5B® ensures ultimate comfort during lengthy working times. You can turn the i-move 2.5B on and off with the remote control. The i-move 2.5B uses a HEPA H11 filter and also includes a fragrance cassette for pleasant smelling air. Combine the i-move 2.5B with our i-brush® if you need extra suction power.

The i-move 2.5B consists of:

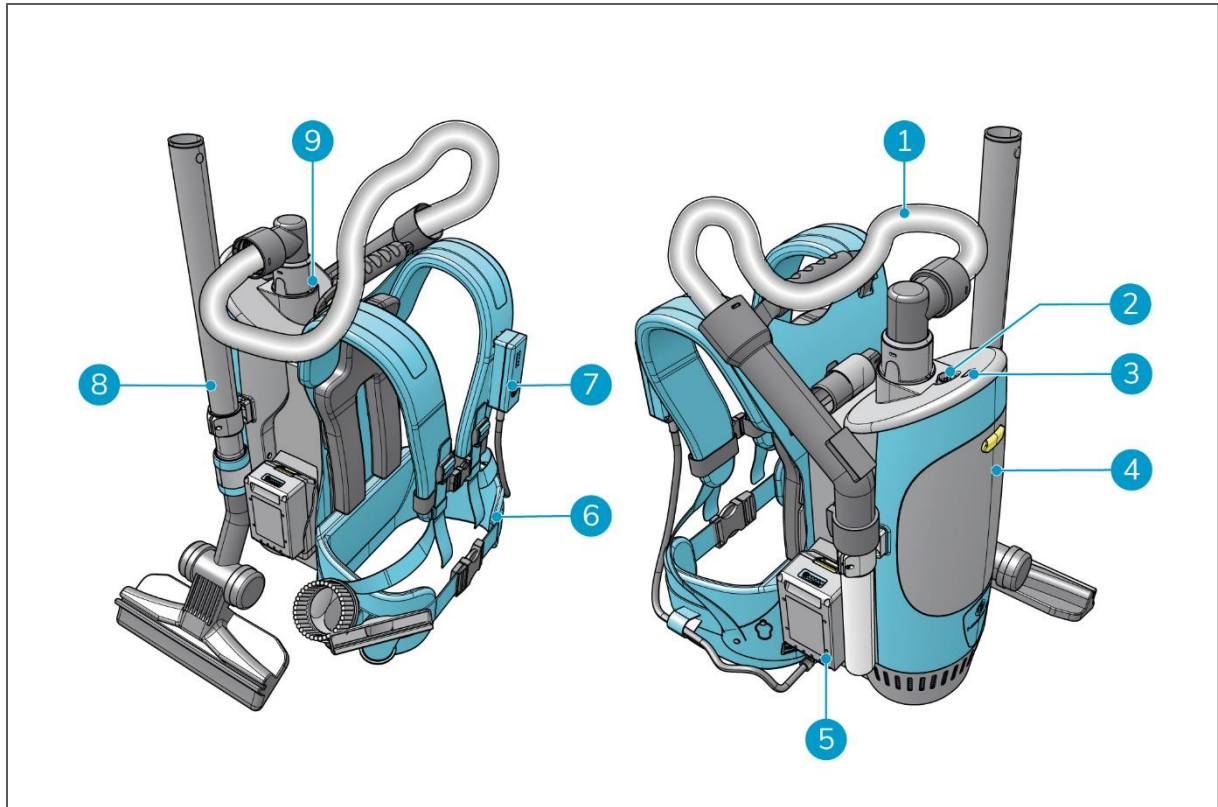

Figure 4

Legend

- | | |
|------------------------------|----------------------|
| 1. A hose. | 6. A harness. |
| 2. An i-brush connector. | 7. A remote control. |
| 3. An hour meter. | 8. A wand. |
| 4. A hatch for the dust bag. | 9. A hose connector. |
| 5. Two battery holders. | |



2.1 The remote control

1. Battery power status display (Figure 5, pos 1). The blue battery power status LEDs are on during normal use. When the battery is full all blue LEDs are on, when the batteries get empty the blue LEDs will go off one by one.
2. ON/OFF button (Figure 5, pos 2).

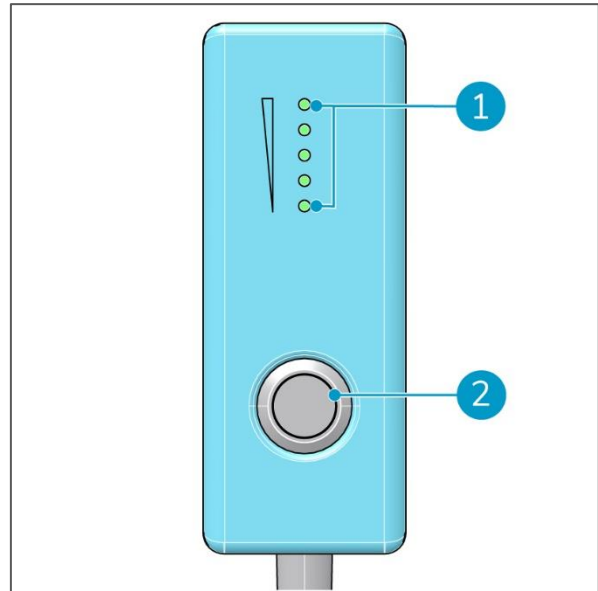

Figure 5



3 Safety

Safety comes first, therefore please take time to read and understand these safety instructions. Improper use can cause harm or void the manufacturer's warranty.

3.1 General Safety Instructions

3.2 Batteries

BATTERY

During normal operation the 14.4 V batteries cause no safety hazard on their own. Please keep in mind the following safety instructions:



- do not crush, pierce or damage in any way;
- do not heat or incinerate;
- do not short-circuit;
- do not dismantle;
- keep the battery dry;
- only charge between 5 °C ~ 40 °C/41 °F ~ 104 °F;
- only use between 5 °C ~ 45 °C/41 °F ~ 113 °F.

3.3 Risks during operation



WARNING

STOP OPERATION IMMEDIATELY if the i-move 2.5B® does not perform properly or makes an unusual noise. Service the i-move 2.5B before you continue the operation.



WARNING

DO NOT operate the i-move 2.5B without a filter dust bag.



WARNING

DO NOT use the i-move 2.5B on damp or wet surfaces. This will cause damage to the i-move 2.5B and is dangerous to the user. The damage caused by the use on a wet surface is not covered under the warranty.



4 Transport and storage

- do not store the i-move 2.5B® outdoors;
- store the i-move 2.5B in a dry place;
- in case the i-move 2.5B is stored for a longer period, remove the battery. See section 6.3.2;
- before you transport the i-move 2.5B , remove the battery. See section 6.3.2;
- before you use the i-move 2.5B again, make sure the battery is loaded, see the User Manual of the i-charge® 5.



5 Assembly and installation

The i-move 2.5B® does not require much assembly, the harness is already attached to the i-move 2.5B. A battery and a battery charger can be ordered separately.

5.1 Unboxing

The i-move 2.5B is packed in 1 box. It includes the i-move 2.5B itself and a starter package of tools.

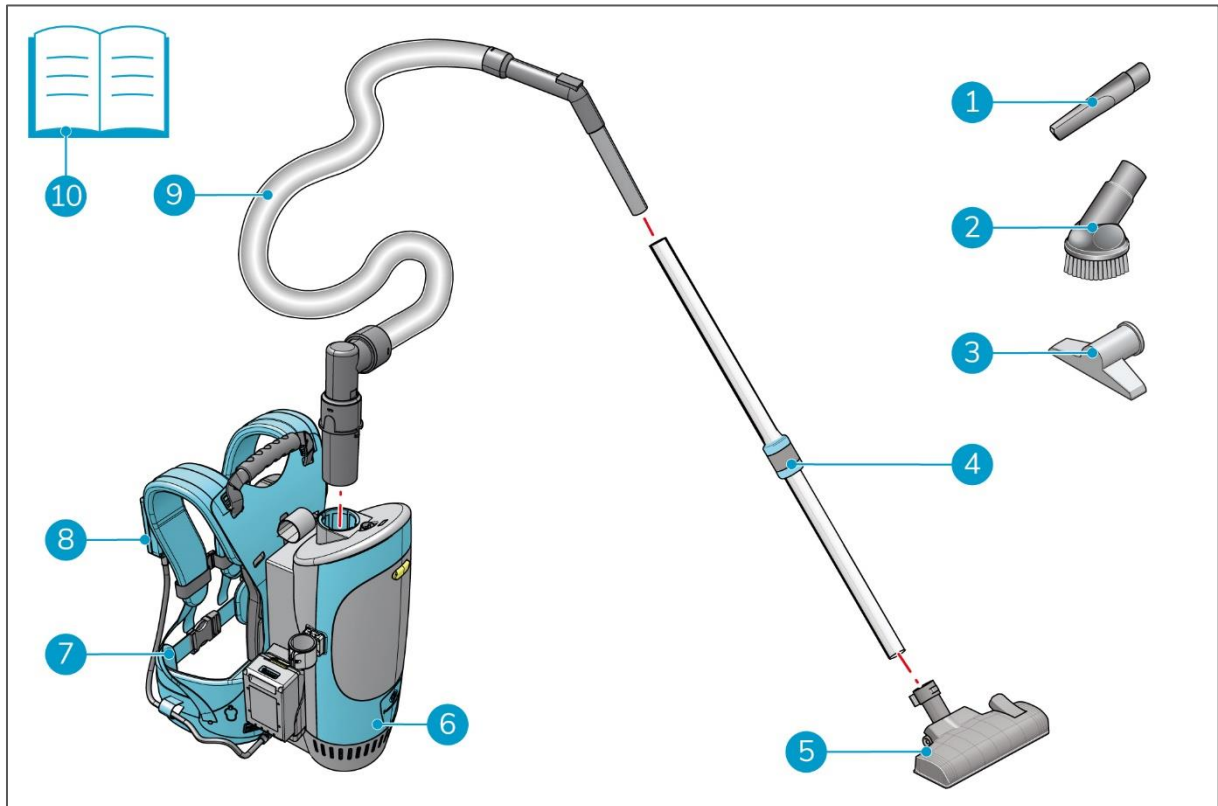

Figure 6

Legend

- | | |
|---------------------------|-------------------------|
| 1. 1x crevice tool | 6. 1x i-move 2.5B |
| 2. 1x round brush | 7. 1x harness |
| 3. 1x upholstery tool | 8. 1x remote control |
| 4. 1x telescopic wand | 9. 1x ESD hose |
| 5. 1x standard floor tool | 10. 1x this user manual |



5.2 Assembly

1. Insert the hose (Figure 7, pos 1) into the body of the i-move 2.5B® (Figure 7, pos 4) and into the wand (Figure 7, pos 2).
2. Attach the desired tool (Figure 7, pos 3) onto the narrow end of the wand.

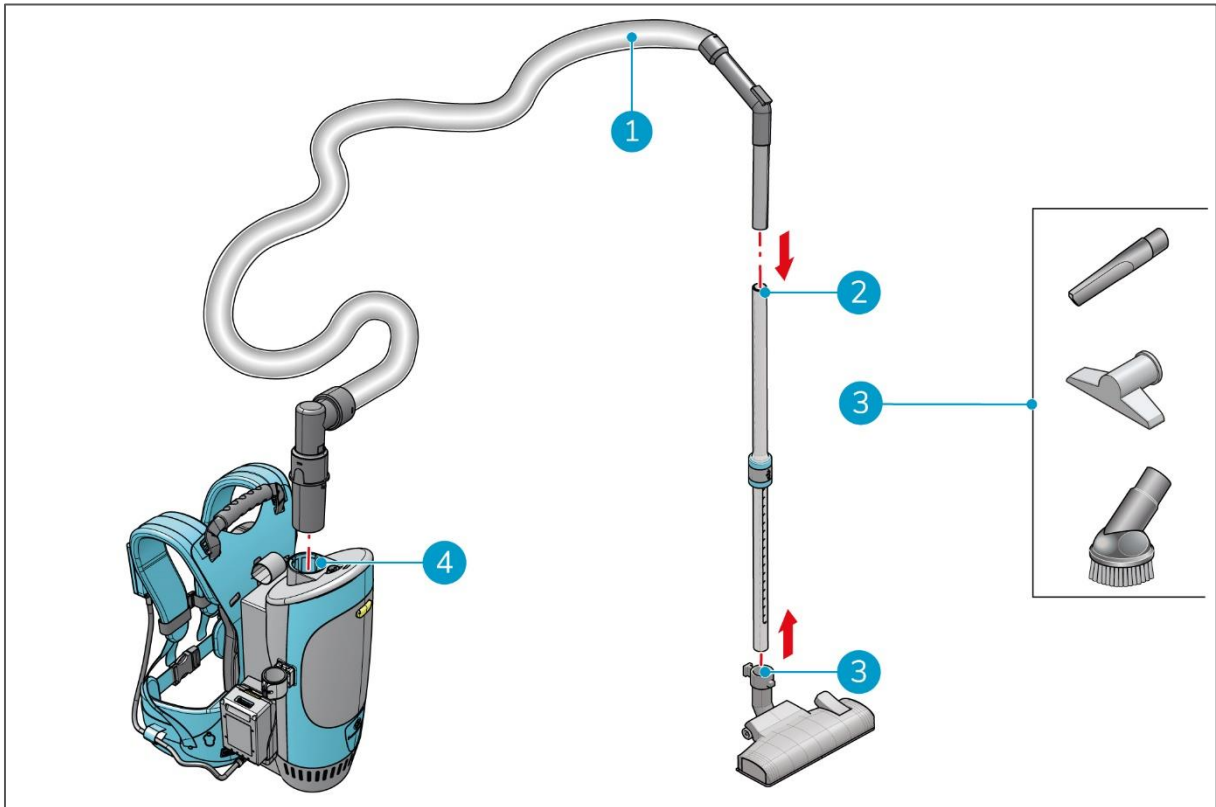

Figure 7



5.3 Replacing the dust bag



ATTENTION

- Only use original i-team dust bags.

1. Place the i-move 2.5B® on a level surface.
2. Push the yellow button (Figure 8, pos 1) to unlock the hatch.
3. Remove the hatch (Figure 8, pos 2).

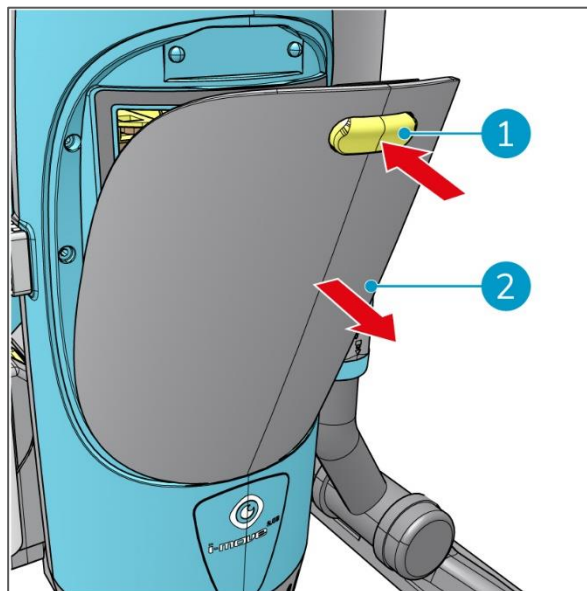

Figure 8

4. Push the yellow button (Figure 9, pos 1) to release the dust bag.
5. Pull the cardboard handle (Figure 9, pos 2) to remove the dust bag (Figure 9, pos 4).
6. Pull the cardboard tag (Figure 9, pos 3) to seal the dust bag.

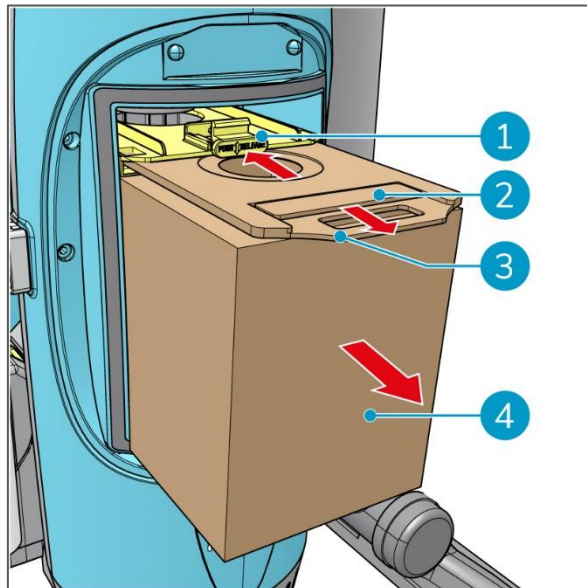

Figure 9

7. Place the yellow holder (Figure 10, pos 1) in its top position. Push the yellow button (Figure 10, pos 2) and it will click into its locked position.
8. Insert the cardboard collar of the new dust bag (Figure 10, pos 3) fully into the yellow bag holder.
9. Replace the hatch (Figure 8, pos 2), press in firmly until it clicks.

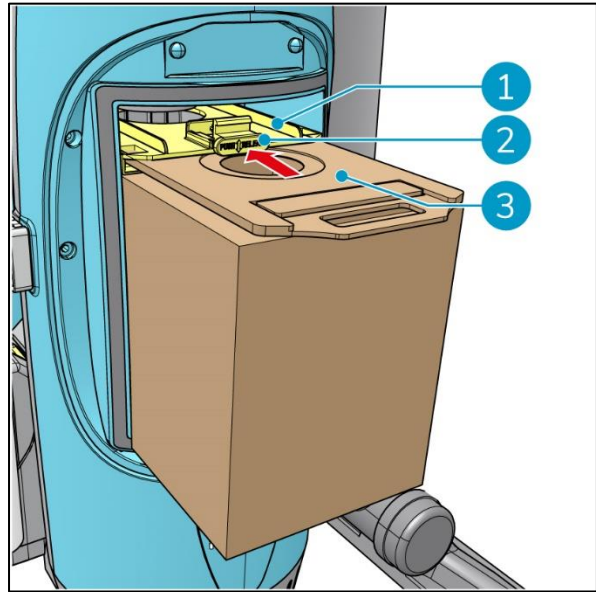

Figure 10



6 Operation

6.1 Before you start

1. Check the i-move 2.5B® for damage or defects.
2. Make sure that the dust bag is placed in the i-move 2.5B.
3. Make sure you have the correct tool for the intended purpose.
4. Check the brush from the tool for wear and tear.
5. Check the motor filter. See section 7.2.2.

6.1.1 Height adjustment

Pull the collar (Figure 11, pos 1) on the wand up to unlock it, adjust the length of the wand and release collar to lock it.

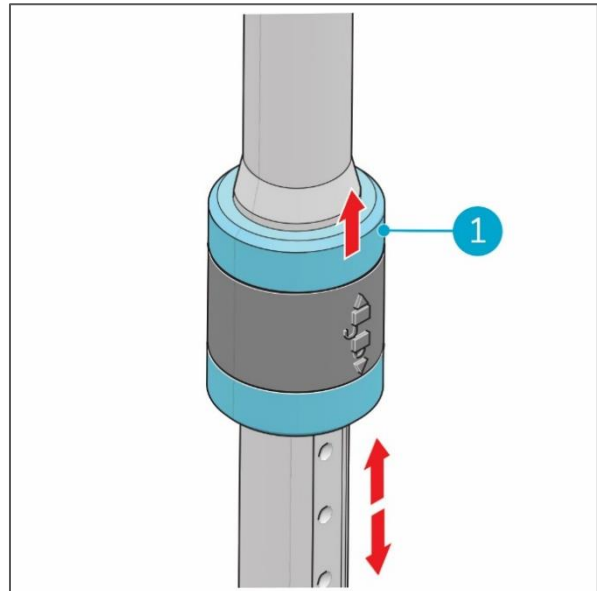

Figure 11

6.1.2 Insert the battery

1. Insert the battery (Figure 12, pos 1) in the slot (Figure 12, pos 2), until you hear a "click". The battery is now fixated. Repeat this for the second battery.

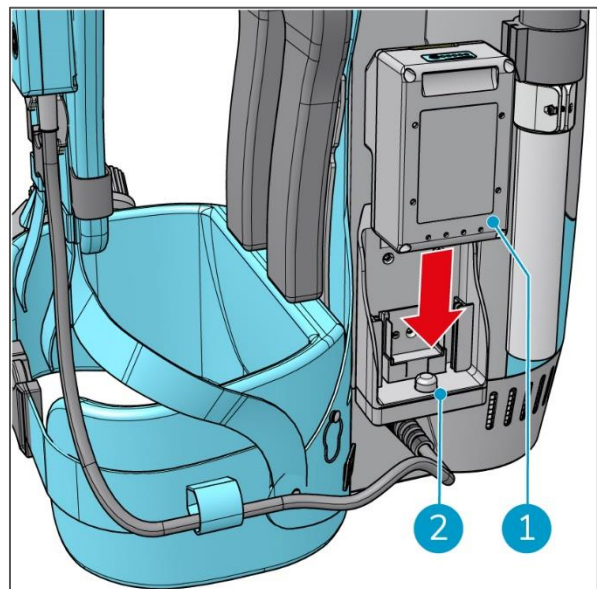

Figure 12



2. Check the batteries by pressing the red button (Figure 13, pos 1) on each individual battery. See also 2.1.
3. Press the ON/OFF switch on the remote control (Figure 13, pos 2) to turn off the i-move 2.5B®.

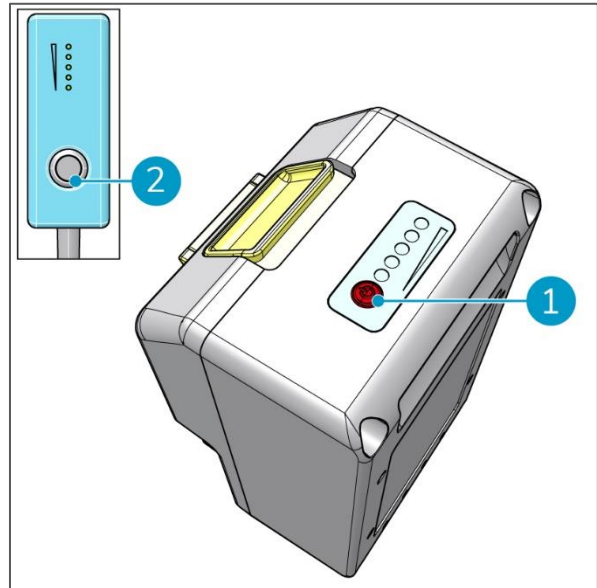

Figure 13

6.2 Normal operation



CAUTION

Make sure that the harness is well adjusted, so it fits comfortably on your body. Otherwise it can cause physical discomfort.

1. Place the i-move 2.5B on a table or similar (Figure 14, pos 4).
2. Open the waistband (Figure 14, pos 3).
3. Loosen the buckle at the front (Figure 14, pos 2).
4. Loosen the 2 buckles (Figure 14, pos 1).

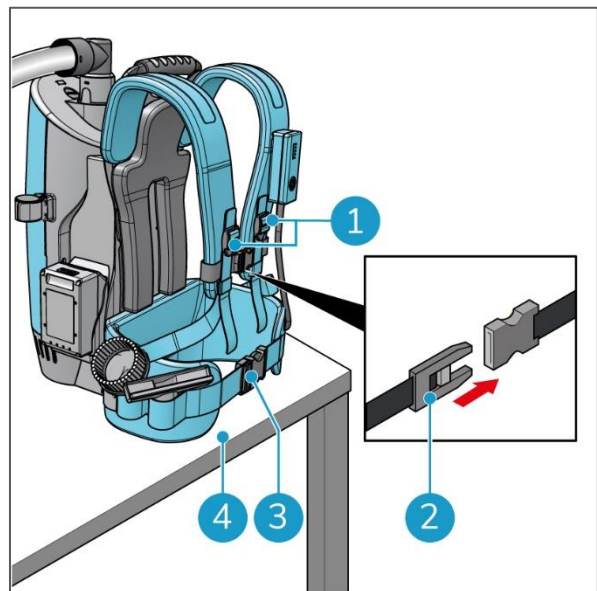

Figure 14



5. Place the i-move 2.5B® on your back (Figure 15, pos 6).
6. Close the waistband, adjust it until it fits comfortably (Figure 15, pos 5).
7. Tighten the 2 buckles until they fit comfortably (Figure 15, pos 2).
8. Fasten the buckle at the front (Figure 15, pos 4).
9. Clip the remote control on the waistband or on one of the buckle loops (Figure 15, pos 1).
10. Press the ON/OFF button (Figure 15, pos 3) to turn on the i-move 2.5B.

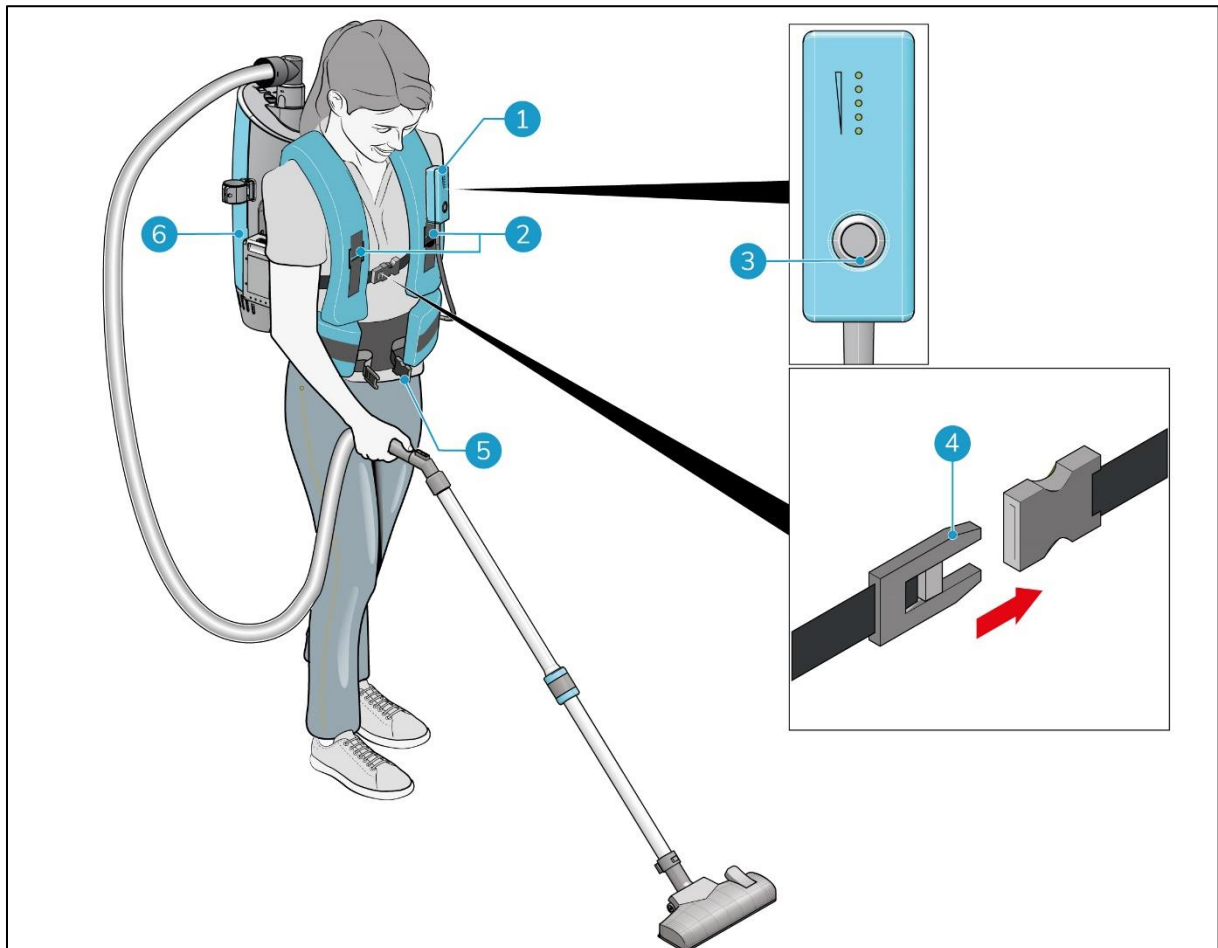

Figure 15



6.2.1 After normal operation

1. Press the ON/OFF switch (Figure 15, pos 3) to turn off the i-move 2.5B®.
2. Undo the buckle at the front (Figure 15, pos 4).
3. Undo the two buckles (Figure 15, pos 2).
4. Open the waistband (Figure 15, pos 5).
5. Remove the remote control from the waistband or on one of the buckle loops (Figure 15, pos 1).
6. Place the i-move 2.5B on a table or similar (Figure 14, pos 4).

6.2.2 Remove the battery

1. Slide the yellow button of the battery (Figure 16, pos 1) towards you to unlock it.
2. Pull out the battery (Figure 16, pos 2).

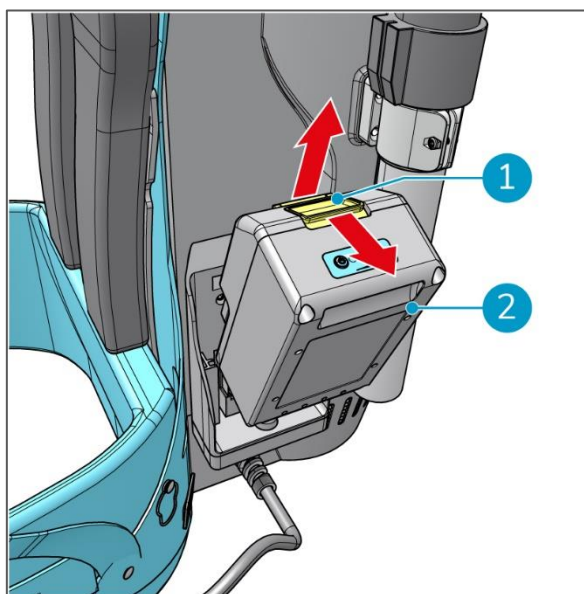

Figure 16



6.3 Operation with i-brush®



CAUTION

Make sure that the harness is well adjusted, so it fits comfortably on your body. Otherwise it can cause physical discomfort.

1. Turn the hose of the standard equipment counterclockwise (Figure 17, pos 1).
2. Remove the hose from the i-move 2.5B®.
3. Insert the hose of the i-brush into the connector (Figure 17, pos 2).
4. Turn the hose of the i-brush clockwise to lock it into place.
5. Connect the plug from the i-brush (Figure 17, pos 3) onto the connector on the i-move 2.5B (Figure 17, pos 4).
6. Tighten the ring of the plug.

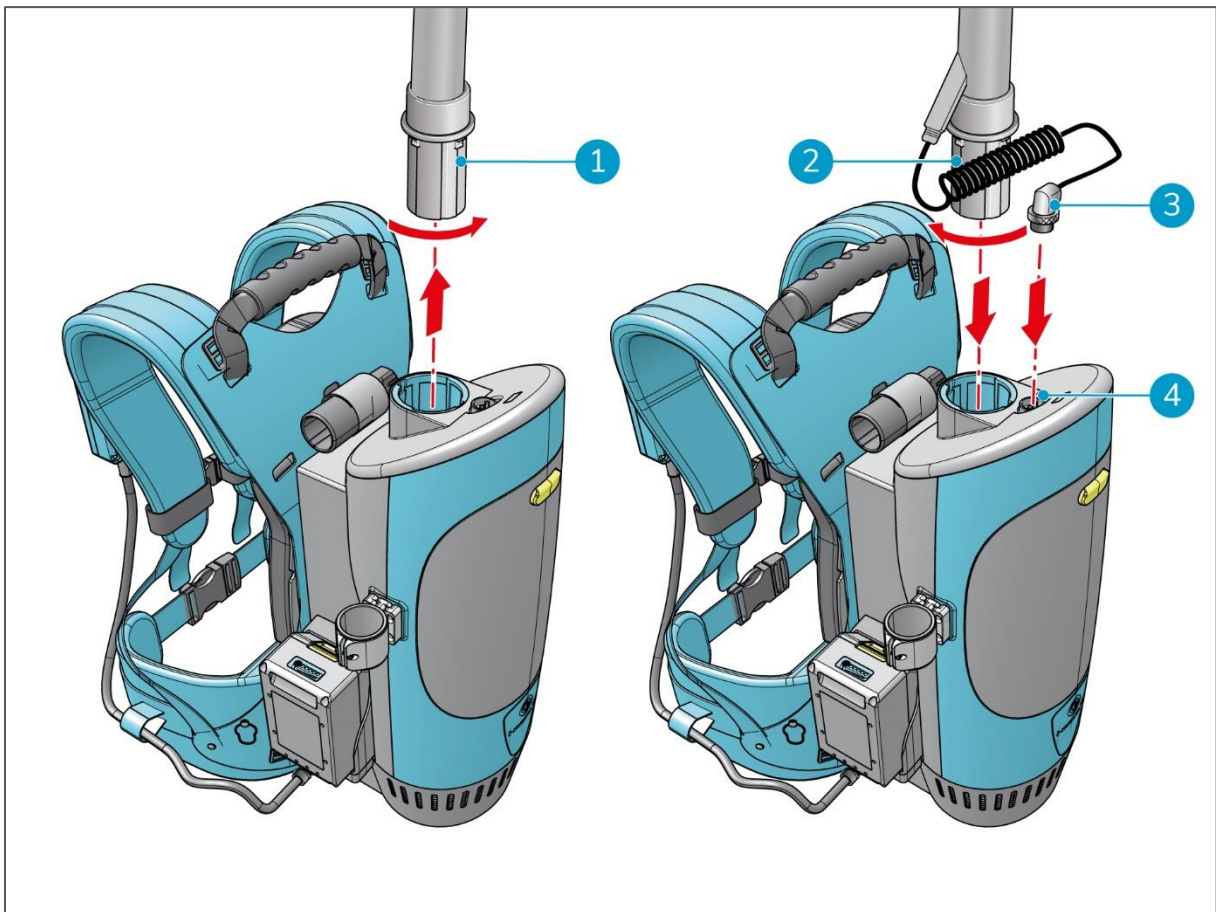

Figure 17

7. Place the i-move 2.5B® on a table or similar (Figure 18, pos 4).
8. Open the waistband (Figure 18, pos 3).
9. Loosen the buckle at the front (Figure 18, pos 2).
10. Loosen the 2 buckles (Figure 18, pos 1).

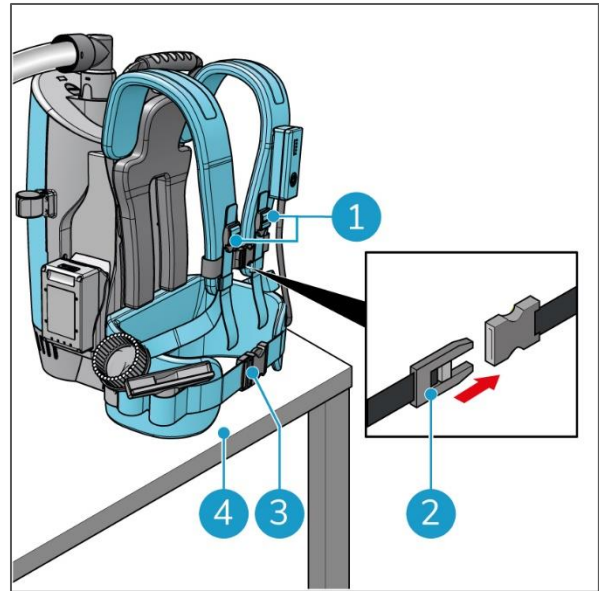

Figure 18



11. Place the i-move 2.5B® on your back (Figure 19, pos 7).
12. Close the waistband, adjust it until it fits comfortably (Figure 19, pos 6).
13. Tighten the 2 buckles until they fit comfortably (Figure 19, pos 2).
14. Fasten the buckle at the front (Figure 19, pos 4).
15. Clip the remote control on the waistband or on one of the buckle loops (Figure 19, pos 1).
16. Press the ON/OFF switch (Figure 19, pos 3) to turn on the i-move 2.5B.
17. Press the ON/OFF switch (Figure 19, pos 5) to turn on the i-brush®, the i-brush works best if no pressure is applied to the brush.

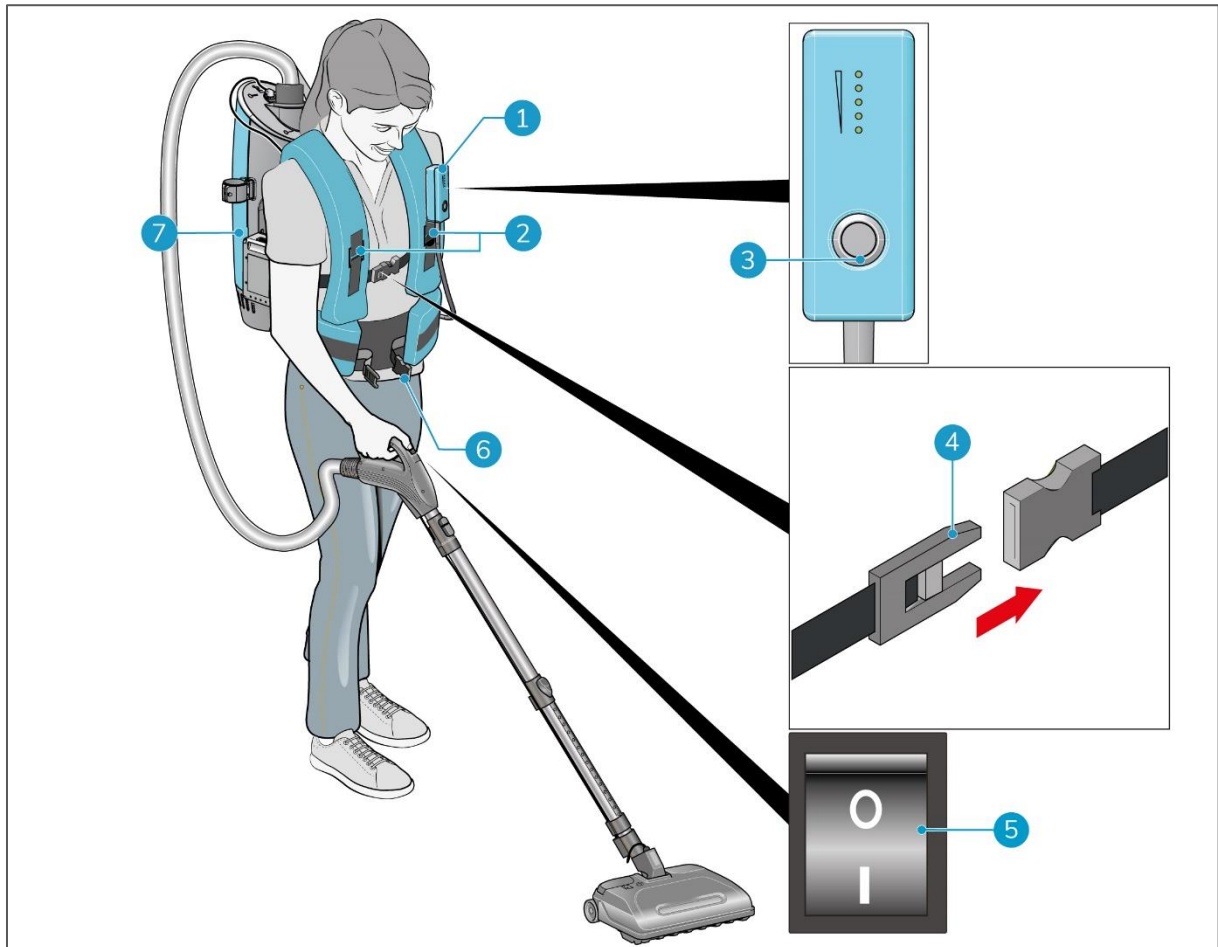

Figure 19



6.3.1 After operation with i-brush®

1. Press the ON/OFF switch (Figure 19, pos 5) to turn off the i-brush.
2. Press the ON/OFF switch (Figure 19, pos 3) to turn off i-move 2.5B®.
3. Undo the buckle (Figure 19, pos 4) at the front.
4. Undo the two buckles (Figure 19, pos 2).
5. Open the waistband (Figure 19, pos 6).
6. Remove the remote control from the waistband or on one of the buckle loops (Figure 19, pos 1).
7. Place the i-move 2.5B on a table or similar (Figure 18, pos 4).

6.3.2 Remove the battery

1. Press the yellow button of the battery (Figure 20, pos 1) to unlock it.
2. Pull out the battery (Figure 20, pos 2).

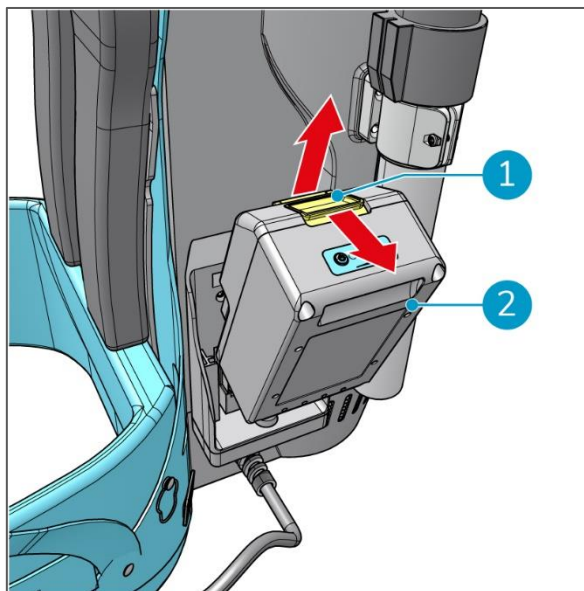

Figure 20



7 Maintenance



WARNING

Before you start maintenance or replacing parts; **Turn off the i-move 2.5B® and remove the battery.**

The i-move 2.5B does not require much maintenance. However it is recommended to clean the machine after using it and before storing it.

For a proper functioning and a long lifespan of the i-move 2.5B, it is important to follow the recommended maintenance intervals mentioned in this manual.

Maintenance that is not described in this manual should be done by your i-move 2.5B partner. Please make sure to have the model and serial number of the i-move 2.5B available when you call a partner. For more information please fill out the contact form on www.i-teamglobal.com.

Maintenance and assembling-disassembling of the i-move 2.5B must be done by an adult person.

7.1 Cleaning



WARNING

DO NOT clean the i-move 2.5B with a high pressure cleaner!
DO NOT submerge the i-move 2.5B in water!

7.1.1 Cleaning the machine

Clean the exterior of the machine using a slightly damp cloth.

7.1.2 Cleaning the hose and wand

Keep the hose and tube clear. Remove objects that cause a blockage by shaking it gently with your hand.



WARNING

DO NOT use a sharp object to clean the hose or wand!

7.1.3 Cleaning the filters

In between filter changes, remove the cassette and the motor filter and gently tap it with your fingers to remove any dust or small pollution. To remove and replace the cassette filter, please see section 7.2.1. To remove and replace the motor filter, please see section 7.2.2.



7.2 Replacing the filters

Check all filters before you start vacuuming. In case they look polluted or clogged, please replace them. Also for optimal performance it is advised to replace the cassette filter and the motor filter every 6 to 8 months.

7.2.1 Replacing the cassette filter



CAUTION

When you place the new cassette filter in the can of the i-move 2.5B®, make sure the arrows on the filter point upwards.

1. Place the i-move 2.5B on a level surface.
2. Push the yellow button (Figure 21, pos 1) to unlock the hatch.
3. Remove the hatch (Figure 21, pos 2).

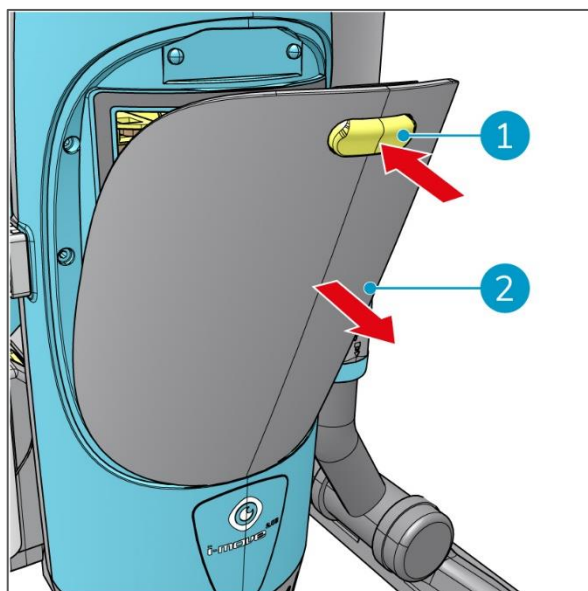

Figure 21

4. Slightly push the grey button (Figure 22, pos 1) to unlock the cassette filter.
5. Pull the cassette filter (Figure 22, pos 2) out of the body of the i-move 2.5B.

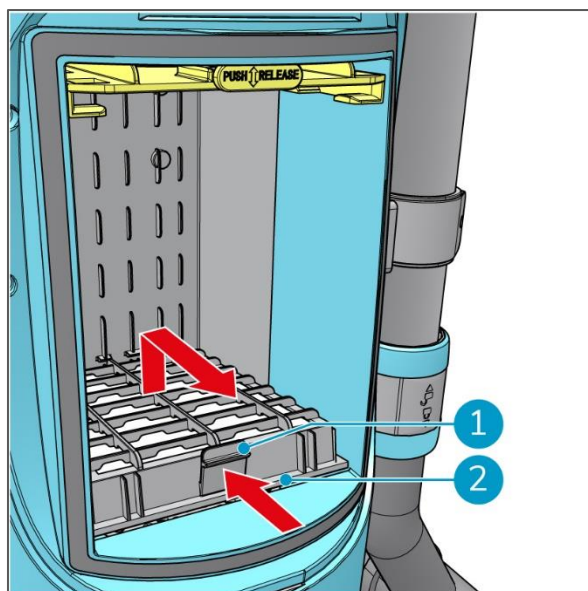

Figure 22



6. Push the new cassette filter into the body of the i-move 2.5B® (Figure 23, pos 1). When the grey button (Figure 22, pos 1) clicks, it is locked.
7. Replace the hatch (Figure 21, pos 2).

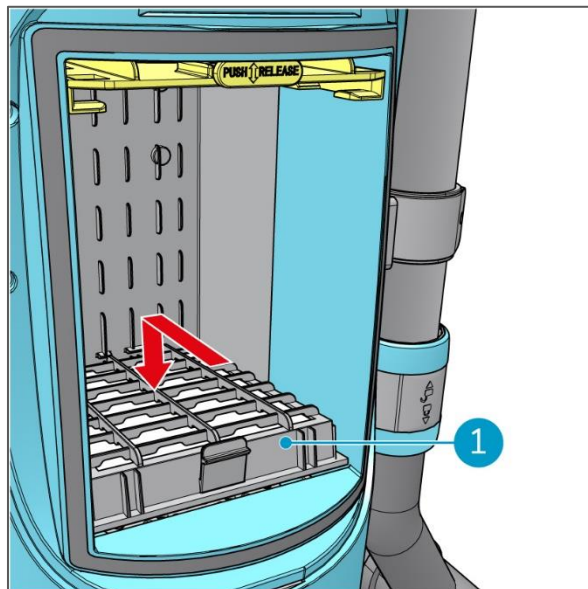

Figure 23

HEPA filter

Your i-move 2.5B is equipped with an H11 HEPA cassette filter, which is perfect for everyday cleaning. The HEPA filter will remove pathogens, allergens and particles that may cause health issues that are often associated with asthma.



7.2.2 Replacing the motor filter

1. Turn off the i-move 2.5B® with the ON/OFF switch (Figure 24, pos 1).
2. Place the i-move 2.5B flat on an horizontal surface.
3. Turn the filter housing (Figure 24, pos 2) counterclockwise to remove it from the bottom of the i-move 2.5B.

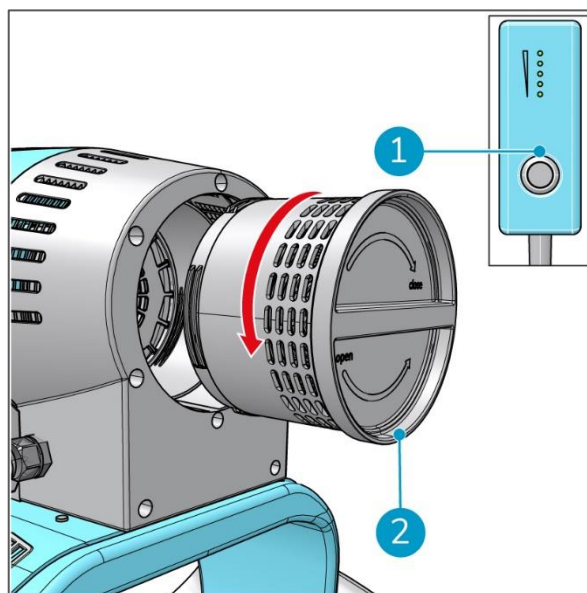

Figure 24

4. Remove the old motor filter (Figure 25, pos 1) from the filter housing.
5. Place the new motor filter (Figure 25, pos 1) in the filter housing (Figure 25, pos 2).
6. Turn the filter housing (Figure 24, pos 2) clockwise to replace it in the bottom of the i-move 2.5B.

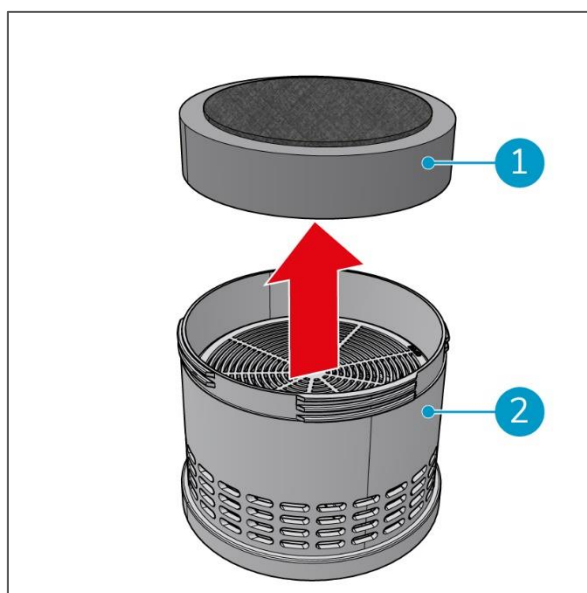

Figure 25



7.2.3 Replacing the fragrance cartridge



ATTENTION

To adapt the strength of the fragrance you can add or remove fragrance pods. The minimum amount is 1 fragrance pod, the maximum amount is 3 fragrance pods.

1. Turn off the i-move 2.5B® with the ON/OFF switch (Figure 26, pos 1).
2. Place the i-move 2.5B flat on an horizontal surface.
3. Turn the filter housing (Figure 26, pos 2) counterclockwise to remove it from the bottom of the i-move 2.5B.

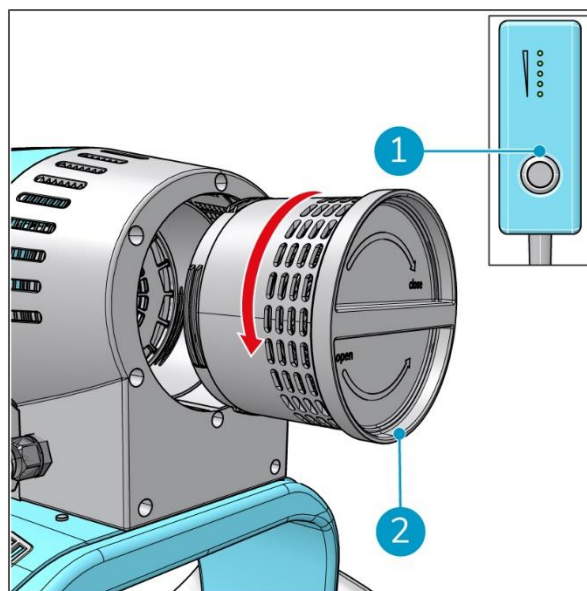

Figure 26

4. Remove the motor filter (Figure 25, pos 1) from the filter housing.
5. Remove the fragrance cartridge (Figure 27, pos 2) from the filter housing.
6. Remove the lid of the fragrance cartridge (Figure 27, pos 1).
7. Place 1, 2 or 3 fragrance pods (Figure 27, pos 3) in the fragrance cartridge.
8. Replace the lid (Figure 27, pos 1) on the fragrance cartridge (Figure 27, pos 2).
9. Replace the fragrance cartridge (Figure 27, pos 2) in the filter housing (Figure 25, pos 2).
7. Replace the motor filter (Figure 25, pos 1) in the filter housing (Figure 25, pos 2).
10. Turn the filter housing (Figure 24, pos 2) clockwise to replace it in the bottom of the i-move 2.5B.

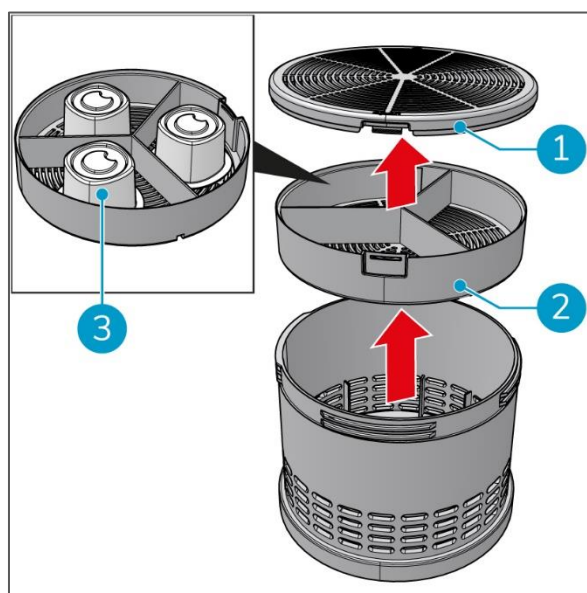

Figure 27



7.3 Brush and tool condition

Check the condition of the tool or brush (i-brush®) before use. Only change the tool or brush when the machine is turned off.

7.4 Damaged or worn parts

Damaged or worn parts need to be replaced immediately. Contact your local i-team Global partner or visit www.i-teamglobal.com for more information.

7.5 Maintenance frequency

Make sure that routine and preventive maintenance is carried out periodically to ensure safe operation. Failure to carry out maintenance as necessary may cause damage to the i-move 2.5B® and may cause a risk to the operator.

Check all filters before you start vacuuming. In case they look polluted or clogged, please replace them.

Clean the cassette filter and the motor filter in between filter changes. See section 7.1.3.

Check the dust bag every week and replace it if it is full. See section 5.3.

Replace the motor filter and the cassette filter every 6 to 8 months. See section 7.2.

Authorized personnel should inspect the i-move 2.5B once every year.

7.6 Storage

See section 4.



8 Trouble shooting

Problem	Cause	Solution
No power, green light in ON/OFF switch does not illuminate	No battery	Insert battery.
	Empty battery	Charge battery.
	ON/OFF switch off	Turn on ON/OFF switch.
Little suction power	Filter bag full	Turn off the i-move 2.5B® and replace filter bag.
	Hose not well attached	Turn off the i-move 2.5B and reattach hose.
	Filters are full	Replace filters.
Battery not charging	Battery is end of life	Replace battery.
	Battery charger is broken	Replace charger.
i-move 2.5B stops working	Motor overheated, a thermal switch stopped the motor	Let the i-move 2.5B cool down. Check the filters, dust bag and hose. Wait approximately 30 minutes. Start the i-move 2.5B by pushing the ON/OFF switch.
	Empty battery	Charge battery.
i-move 2.5B makes strange sound	Motor is broken	Replace motor.
	Hose blocked	Turn off the i-move 2.5B and remove blockage.
	Dust bag is full	Turn off the i-move 2.5B and change dust bag.
i-move 2.5B smells strange	Filter is full	Turn off the i-move 2.5B and replace filter.
	Fragrance beads are used up	Replace the fragrance beads.
	Dust bag is full	Turn off the i-move 2.5B and change dust bag.



9 Decommissioning and disposal



ATTENTION

It is the responsibility of the i-move 2.5B® owner to dispose of the product.

At the end-of-life the i-move 2.5B still contains valuable resources and needs to be disposed of according to your local laws and regulations regarding recycling of electrical equipment.



1. Remove the battery for separate disposal (see section 6.2.2).

TIP:

Alternatively, keep the battery for use in another piece of i-team equipment.

2. Remove all loose components.
3. Dispose of all items according to your local laws and regulations.

TIP:

Contact your local i-team partner to explore all possibilities of returning components at the end-of-life of your i-move 2.5B.



10 Attachments

10.1 CE Certificate



EG/EC DECLARATION OF CONFORMITY

We: i-team PROFESSIONAL

Hereby declare the following equipment:

Product: Vacuum Cleaner

Model: I-MOVE 2.5B

Rating: DC24V, 450W

Class III

IPX0

Fufils all the relevant provisions of European low Voltage Directive 2014/35/EU and EMC Directive 2014/30/EU. This equipment has been designed and manufactured in accordance with following harmonized European standards:

EN 55014-1: 2017

EN 55014-2: 2015

Eindhoven, 02 November 2020

(Place and Date of issue)

Frank van de Ven
Director

(name and signature or equivalent marking or authorized person)



This document is part of the technical file of the i-move 2.5B® and will be available upon request.